

Type 47900 & 48000 Furnaces

OPERATION MANUAL Series 1165, 1166 & 1205

Single Setpoint Models	F47910, F47910-26, F47910-33, F47914, F47915, F48010, F48010-26, F48010-33, F48014, F48015, F48015-60, F48018
Single Setpoint Models with OTP	F47920, F47920-26, F47920-33, F47924, F47925, F48020, F48020-26, F48020-33, F48024, F48025, F48025-60, F48028
8 Segment Programmable Models with OTP	F47920-80, F47920-26-80, F47920-33-80, F47924-80, F47925-80, F48020-80, F48020-26-80, F48020-33-80, F48024-80, F48025-80, F48025-60-80, F48028-80
4 X 16 Segment Programmable Models with OTP	F47950, F47950-26, F47950-33, F47954, F47955, F48050, F48050-26, F48050-33, F48055, F48055-60, F48058

Table of Contents

Safety Information	3
Alert Signals.....	3
Warnings	3
Introduction.....	5
Intended Use	5
General Usage.....	5
Principles of Operation	5
General Specifications	6
Type F47900 Models	6
Type F48000 Models	6
Environmental Conditions	7
Declaration of Conformity	7
Unpacking	8
Installation	9
Site Selection.....	9
Electrical Connections	9
Operation, All Models	10
Power Switch	10
Cycle Light	10
Door Safety Switch	10
Single Setpoint Models & Single Setpoint Models with OTP	11
Single Ramp & Dwell	16
8 Segment & 4 x 16 Segment Programmable Models with OTP	19
Furnace Loading	39
Preventative Maintenance	40
General Cleaning Instructions	40
Troubleshooting	41
Maintenance and Servicing	44
To Replace a Heating Element	44
To Replace a Chromel/Alumel Thermocouple	45
To Replace Door Switches (Micro-Switch)	46
To Realign Door Switches (Micro-Switch)	47
To Replace the Controller	48
Replacement Parts.....	49
Single Setpoint Models	49
Single Setpoint Models with OTP	49
8 Segment Programmable Models with OTP	50
4 x 16 Segment Programmable Models with OTP	50
Wiring Diagrams.....	51
Ordering Procedures	59
One Year Limited Warranty	60

Safety Information

Alert Signals



Warning

Warnings alert you to a possibility of personal injury.



Caution

Cautions alert you to a possibility of damage to the equipment.



Note

Notes alert you to pertinent facts and conditions.



Hot Surface

Hot surfaces alert you to the possibility of personal injury if you come in contact with a surface during use or for a period of time after use.

Your Barnstead Thermolyne Type 47900 or 48000 Furnace has been designed with function, reliability and safety in mind. It is your responsibility to install it in conformance with local electrical codes. For safe operation, please pay attention to the alert signals throughout the manual.

This manual contains important operating and safety information. You must carefully read and understand the contents of this manual prior to the use of this furnace.

Warnings

To avoid electrical shock, this furnace must:

1. Use a properly grounded electrical outlet of correct voltage and current handling capacity.
2. Be disconnected from the power supply prior to maintenance and servicing.
3. Have the door switch operating properly.

To avoid personal injury:

1. Do not use in the presence of flammable or combustible materials; fire or explosion may result. This device contains components which may ignite such material.
2. Caution: Hot Surface - Avoid Contact. To avoid burns, do not touch the exterior or interior surfaces of this furnace during use or for a period of time after use.
3. Always wear safety glasses or a safety shield and high temperature gloves when loading or unloading the furnace. Long sleeved, fire retardant clothing and a fire retardant apron is also recommended.
4. Refer servicing to qualified personnel.

**Warning**

Refer Servicing to qualified personnel.

Warning

This warning is presented for compliance with California Proposition 65 and other regulatory agencies and only applies to the insulation in this product. This product contains refractory ceramic, refractory ceramic fiber or fiberglass insulation, which can produce respirable dust or fibers during disassembly. Dust or fibers can cause irritation and can aggravate pre-existing respiratory diseases. Refractory ceramic and refractory ceramic fibers (after reaching 1000°C) contain crystalline silica, which can cause lung damage (silicosis). The International Agency for Research on Cancer (IARC) has classified refractory ceramic fiber and fiberglass as possibly carcinogenic (Group 2B), and crystalline silica as carcinogenic to humans (Group 1).

The insulating materials can be located in the door, the hearth collar, in the chamber of the product or under the hot plate top. Tests performed by the manufacturer indicate that there is no risk of exposure to dust or respirable fibers resulting from operation of this product under normal conditions. However, there may be a risk of exposure to respirable dust or fibers when repairing or maintaining the insulating materials, or when otherwise disturbing them in a manner which causes release of dust or fibers. By using proper handling procedures and protective equipment you can work safely with these insulating materials and minimize any exposure. Refer to the appropriate Material Safety Data Sheets (MSDS) for information regarding proper handling and recommended protective equipment. For additional MSDS copies, or additional information concerning the handling of refractory ceramic products, please contact the Customer Service Department at Barnstead International at 1-800-553-0039.

Introduction



Caution

Do not exceed operating temperatures shown in “General Specifications.” Exceeding these limits will result in severely reduced element life.

Intended Use

The Type F47900 and F48000 furnaces are general purpose laboratory and heat treating furnaces. For optimum element life, Barnstead International recommends observing these temperature ranges: from 100°C (212°F) to 1093°C (2000°F) continuous use or from 1093°C (2000°F) to 1200C (2192°F) for intermittent use. Continuous use is operating the furnace for more than 3 hours and intermittent use is operating the furnace for less than 3 hours.

All furnaces consist of: 1) a vented heating chamber; 2) a temperature controller; and 3) a door safety switch for operator safety.

General Usage

Do not use this product for anything other than its intended usage.

Principles of Operation

The furnace chamber is heated by open coil electric resistance elements and is insulated with ceramic fiber insulation. The controller is located under the furnace chamber and is well insulated from the heat generated in the furnace chamber. A door safety switch removes power to the heating elements whenever the furnace door is opened. The temperature is controlled by one of three types of controllers.

General Specifications

Type F47900 Models

Dimensions in Inches (cm):

Chamber: 5 (12.7) W x 4 (10.2) H x 6 (15.2) D
Overall: 11.25 (28.6) W x 18 (45.7) H x 15.5 (39.4) D

Weight: 37 lb. (16.8 kg)

Electrical Ratings:

Volts:	220-240	100	120
Amps:	4.2	7.5	8.3
Watts:	1000	750	1000
Frequency:	50/60	50/60	50/60
Phase:	1	1	1

Temperature:

Operating Range: 2000°F (1093°C) continuous
2192°F (1200°C) intermittent

Type F48000 Models

Dimensions in Inches (cm):

Chamber: 7 (17.8) W x 5 (12.7) H x 10 (25.4) D
Overall: 13.25 (33.7) W x 19 (48.3) H x 19.5 (49.5) D

Weight: 56 lb. (25.4 kg) (all models except -33)
58 lb. (26.3 kg) (-33 models only)

Electrical Ratings:

Volts:	220-240	120	208	100	220-240*
Amps:	7.5	14.5	15	14.5	6.5*
Watts:	1800	1500	1560	1450	1560*
Frequency:	50/60	50/60	50/60	50/60	50/60*
Phase:	1	1	1	1	1*

* -33 models only

Temperature:

Operating Range: 2000°F (1093°C) continuous
2192°F (1200°C) intermittent

Environmental Conditions

Operating: 17°C to 27°C; 20% to 80% relative humidity, non-condensing. Installation Category II (overvoltage) in accordance with IEC 664. Pollution degree 2 in accordance with IEC 664.

Altitude Limit: 2,000 meters.

Storage: -25°C to 65°C; 20% to 80% relative humidity

Declaration of Conformity

Barnstead International hereby declares under its sole responsibility that this product conforms with the technical requirements of the following standards (220-240 Volt Models Only):

EMC:	EN 50081-1	Generic Emissions Standard
	EN 50082-2	Generic Immunity Standard
Safety:	EN 61010-1	Safety Requirements for Electrical Equipment for Measurement, Control and Laboratory Use; Part I: General Requirements
	EN 61010-2-010	Part II: Particular Requirements for Laboratory Equipment for the Heating of Materials

per the provisions of the Low Voltage Directive 73/23/EEC, as amended by 93/68/EEC.

The authorized representative located within the European Community is:

Electrothermal Engineering Ltd.
419 Sutton Road
Southend On Sea
Essex SS2 5PH
United Kingdom

Copies of the Declaration of Conformity are available upon request.

Unpacking

1. Visually check for any physical damage to the shipping container.
2. Inspect the equipment surfaces that are adjacent to any damaged area.
3. Open the furnace door and remove the packing material from inside the furnace chamber.
4. Vacuum the chamber prior to use to remove the insulation dust due to shipment. (The Type 48000 furnace is supplied with one ceramic shelf.)
5. Retain the original packaging material if reshipment is foreseen or required.

Installation

**Caution**

Be sure ambient temperature does not exceed 40°C (104°F). The recommended ambient temperature is 17°C - 27°C. Ambients above this level may result in damage to the controller.

**Caution**

Allow at least six inches of space between the furnace and any combustible surface. This permits the heat from the furnace case to escape so as not to create a possible fire hazard.

**Warning**

To avoid electrical shock, this furnace must always use a properly grounded outlet of correct voltage and current handling capacity.

Site Selection

Install furnace on a sturdy surface and allow adequate space for ventilation.

Electrical Connections

The electrical ratings are located on the specification plate on the back of the furnace. Consult Barnstead International if your electrical service is different than those listed on the specification plate. Be sure the front power switch is in the OFF position before connecting the furnace to your electrical supply.

Operation, All Models



Warning

To avoid personal injury do not use in the presence of flammable or combustible chemicals; fire or explosion may result. This device contains components which may ignite such materials.



Hot Surface

Caution: Avoid Contact. To avoid burns, this furnace must not be touched on the exterior or interior surfaces during use or for a period of time after use.



Warning

Always wear safety glasses or a safety shield and high temperature gloves when loading or unloading the furnace. Long sleeved, fire retardant clothing and a fire retardant apron is also recommended.



Warning

To avoid electrical shock, the door safety switch must be operating properly.

Power Switch

Both the ON/OFF power switch and the digital display will illuminate when power is switched ON. The furnace will begin to heat to its controller's current setpoint. (See the instructions for your type of controller for information on checking and setting the setpoint.)

Cycle Light

The amber cycle light will illuminate whenever the power is being applied to the heating elements. The cycle light will turn on and off as the furnace reaches the setpoint.

Door Safety Switch

The door safety switch removes power from the heating elements when the door is opened. Open and close the door a few times; note that the amber CYCLE light will switch off when the door is opened. If this condition is not true, consult the Troubleshooting section before proceeding. This check must be done when the furnace is heating and the cycle light is illuminated.

Single Setpoint Models & Single Setpoint Models w/OTP

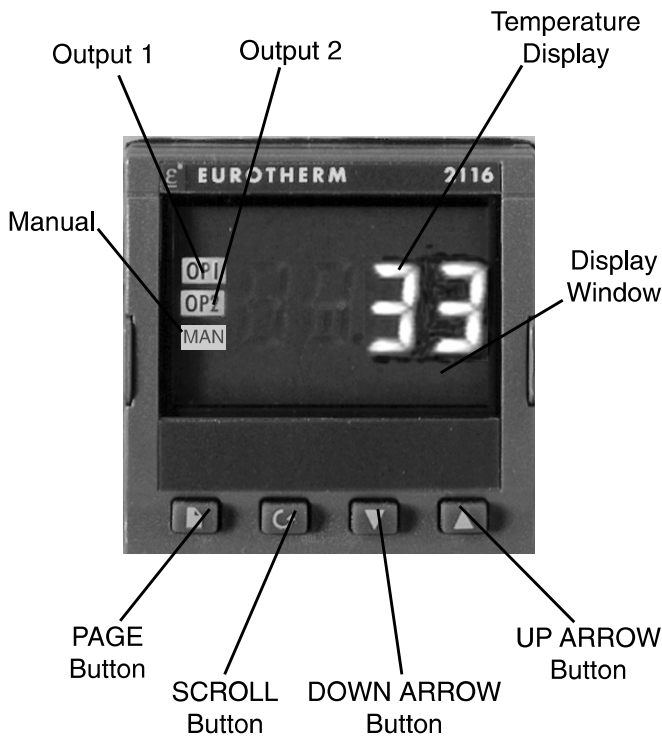

Single Setpoint Models



Note

If at any time you want to return to the HOME DISPLAY, simultaneously press the PAGE and SCROLL buttons.

The **single setpoint model** furnace controller is a single setpoint controller which provides a single digital display to indicate the current chamber temperature or setpoint temperature. This temperature controller features sensor break protection and self-tuning capability.

The **single setpoint model w/ OTP** furnace controller is a single setpoint controller which provides a single digital display to indicate the current chamber temperature or setpoint temperature. This temperature controller features sensor break protection, self-tuning capability and over temperature protection (OTP) with an additional OTP relay device.

Basic Operation

When the controller is turned ON it will perform a short self-test and then display the measured value (process value) in the HOME DISPLAY.

Buttons and Indicators

OP1 (Output 1): Illuminates when the logic output is ON.

OP2 (Output 2): Illuminates when the relay output is ON (will go out during an alarm situation).

PAGE button: Allows you to select a new list of parameters.

SCROLL button: Allows you to select a parameter within a list of parameters.

DOWN button: Allows you to decrease a value.

UP button: Allows you to increase a value.

To View or Change the Setpoint

To view the setpoint, press and release the UP or DOWN buttons. If you want to change the setpoint, continue pressing until the desired setpoint value is displayed and then release the button. A few seconds after the button is released, the controller will accept the new value and revert to the HOME DISPLAY.

To View the Display Units

From the HOME DISPLAY press the SCROLL button. The display will show the temperature units in °C/F/K and then return to the HOME DISPLAY. (Call Customer Service if you require a different temperature unit.)

To View the % Output Power

From the HOME DISPLAY press the SCROLL button twice. Press and release the UP or DOWN button to view the % output power. This value is a read-only value and cannot be changed.

Controller Parameters

Home display

°C: Temperature units in Celsius. Temperature units can not be changed without entering the configuration. Contact Customer Service if a different temperature unit is required.

OP: % output power demand.

IdHi: Deviation high alarm.

AI List

IdHi: Deviation high alarm.

Atun List

tunE: One-shot autotune enable.

Pid List

Pb: Proportional band (in display units).

ti: Integral time in seconds.

td: Derivative time in seconds.

ACCS List Code: Access code (Code needed to enter or change the other configuration parameters which are not normally accessible.) Not accessible.

Alarms

The controller will flash an alarm message in the home display if an alarm condition is detected.

2FSH: Measured value full scale high alarm.

IdHi: Measured value deviation high alarm.

S.br: Sensor break: check that sensor is connected correctly.

L.br: Loop break: check that the heating circuits are working properly.



Note

The following alarm messages are factory default settings and may vary if you have changed the configuration of your controller:

IDHi: = 50°C
2FSH = 1225°C

Ld.F: Heater Circuit fault: indication of either an open or short solid state relay, a blown fuse, missing supply or open circuit heater.

Sensor Break Protection

This controller provides sensor break protection in the event the thermocouple opens. If an open thermocouple condition occurs, the digital display will blink “S.br” and the power to the heating element will be shut OFF (Cycle light will extinguish).

Over-Temperature Protection (OTP)

The OTP will be in effect during any alarm condition when the temperature of the furnace has deviated beyond the limit. The “Deviation High” alarm is the only alarm value which can be changed. To change it, press the SCROLL button until “IdHi” appears on the display. Press the UP or DOWN button to select the OTP value you desire. We recommend a value of 20° above your working temperature to provide protection for your workload.

In addition to over-temperature protection, units containing a single setpoint controller w/OTP feature a mechanical OTP relay device which disconnects power from the elements in an alarm condition (only in furnaces with OTP relay). See models listed on front page.

Tuning

This controller incorporates a self-tuning feature which determines the optimum control parameters for the best temperature accuracy with your load and setpoint. Use this feature the first time you use your furnace and each time you change either your setpoint or the type of load you are heating.

Barnstead|Thermolyne recommends you use this feature to provide the best temperature accuracy the controller can attain. To use the tuning feature:

1. Adjust the setpoint to your desired value.
2. Press the PAGE button until display reads, "Atun."
3. Press the SCROLL button. Display will read, "tunE."
4. Press the UP or DOWN button to select, "on."
5. Simultaneously press the PAGE and SCROLL buttons to return to the HOME DISPLAY. The display will alternately flash between "tunE" and the HOME DISPLAY while tuning is in progress.
6. The controller will then turn the heating on and off to induce an oscillation. When the measured value reaches the required setpoint the first cycle will end.
7. Tuning will be complete after two oscillation cycles and then the tuner will turn itself off.
8. Normal control function will resume after the controller calculates tuning parameters.



Note

Furnace must be at ambient temperature before starting a tune.



Note

Tune has completed when "tunE" stops flashing on display.

Single Ramp & Dwell



Note

These instructions are used with the Single Setpoint models with OTP only (See models listed on front page).

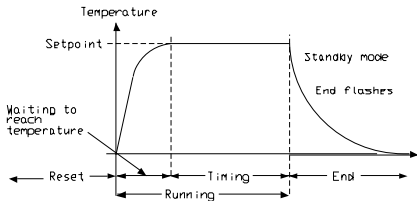

Mode 1 (Opt. 1)

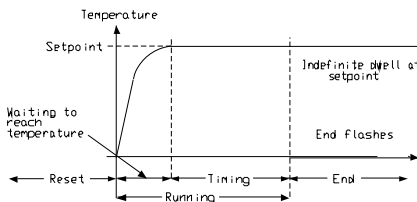

Mode 2 (Opt. 2)

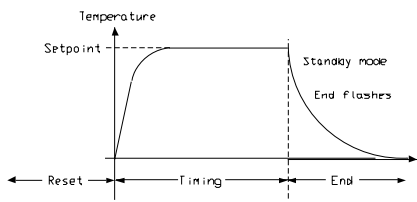

Mode 3 (Opt. 3)

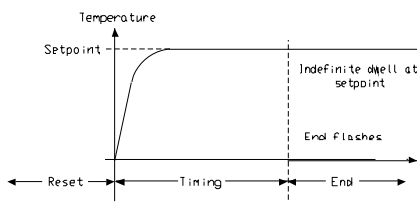

Mode 4 (Opt. 4)

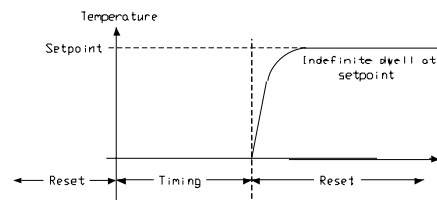

Mode 5 (Opt. 5)

Functions

This type of controller has single ramp and dwell programming capabilities. The Ramp and Dwell can be configured to five different modes.

1. Mode 1 (Opt. 1) is a Ramp (if needed) to the Setpoint temperature, a Dwell, and then a cool down.
2. Mode 2 (Opt. 2) is the same as mode 1, except the controller continues to heat at the Setpoint after the Dwell has completed. (This mode does not cool down.)
3. Mode 3 (Opt. 3) is the same as mode 1, except the Dwell time includes the Ramp (if needed).
4. Mode 4 (Opt. 4) is the same as mode 2, except the Dwell time includes the Ramp (if needed).
5. Mode 5 (Opt. 5) is a Dwell (delay time) before the controller Ramps (if needed) to the Setpoint temperature.

Setting Variables

- The Manual or Automatic modes can be set by changing “m-A” variable to “mAn” or “Auto.” (The Manual mode will keep the controller from heating without setting the Setpoint temperature below the Actual temperature. The Automatic mode will allow the controller to heat to the Setpoint temperature. (The controller should be left in the Automatic mode except when programming.)
- A program mode can be set by changing the “tm.OP” variable to “Opt. 1, Opt. 2, Opt. 3, Opt. 4, or Opt. 5.

- A Ramp rate may be set by changing the “SPrr” variable to a value. The Ramp rate units are in degrees per minute.
- The Dwell time can be set by changing the “dwEll” variable to the desired value. Dwell time units are in minutes.
- The program Status can be set by changing the “StAt” variable to “run” or “oFF.” This variable will start or stop the program.



Note

The program must be stopped and the controller must be displaying the actual temperature before beginning the Setup.

Program Setup

1. Press the SCROLL button until “m-A” is displayed, then set to “mAn” with the UP or DOWN buttons.
2. Press the PAGE button once, set the desired Setpoint temperature with the UP or DOWN buttons.
3. Press the PAGE button until the “SP” is displayed.
4. Press the SCROLL button once, “SPrr” (Ramp Rate) will be displayed, set the desired Ramp rate with the UP or DOWN buttons, if the ramp to setpoint feature is needed. If the Ramp rate is not needed, then set to “OFF” with the UP or DOWN buttons.
5. Press the SCROLL button once, “tm.OP” (Ramp & Dwell mode) will be displayed, select the desired mode with the UP or DOWN buttons. (Opt. 1, Opt. 2, Opt. 3, Opt. 4, Opt. 5)
6. Press the SCROLL button once, “dwEll” will be displayed, set the desired Dwell time with the UP or DOWN buttons. (Dwell in minutes.)
7. Press the PAGE button until the Actual temperature is displayed.

Running the Program

1. Press the SCROLL button until “StAt” is displayed, set to “run” with the UP or DOWN buttons.
2. Press the PAGE button to display Actual temperature.

Stopping the Program

Press the SCROLL button until “StAt” is displayed, set to “oFF” with the UP or DOWN buttons.

Clearing the Flashing End

Press the PAGE and SCROLL buttons at the same time.

Switching from Manual Mode to Auto Mode

Press the SCROLL button until “m-A” is displayed. Press the UP or DOWN buttons to set to “Auto.” Press PAGE button to display Actual temperature.

Verifying a Running Program

Press the SCROLL button until “StAt” is displayed. The display will show “run” if the program is running, or “oFF” if it is not running. Press the PAGE button to display Actual temperature.

8 Segment & 4x16 Segment Programmable Models w/OTP



Note

The controller will return to the HOME DISPLAY if left idle for more than a few seconds.



Note

Once the desired parameter has been selected, depressing either the UP or DOWN button will change the parameter value. In all cases, the value shown on the display is the current working value of that parameter.

The **8 segment programmable** controller consists of a microprocessor based three-mode PID (Proportional, Integral, Derivative), programmable temperature controller with over-temperature protection and appropriate output switching devices to control the furnace. The digital readout continuously displays chamber (upper display) and setpoint (lower display) temperatures unless the SCROLL or PAGE button is depressed. The programmable controller can be used as a single setpoint controller or as a programmable controller. The 8 segment digital model enables eight segments of programming.

The **4x16 segment programmable** controller consists of a microprocessor based three-mode PID (Proportional, Integral, Derivative), programmable temperature controller with over-temperature protection and appropriate output switching devices to control the furnace. The digital readout continuously displays chamber (upper display) and setpoint (lower display) temperatures unless the SCROLL or PAGE button is depressed. The programmable controller can be used as a single setpoint controller or as a programmable controller. The 4 program controller has four 16 segment programs.

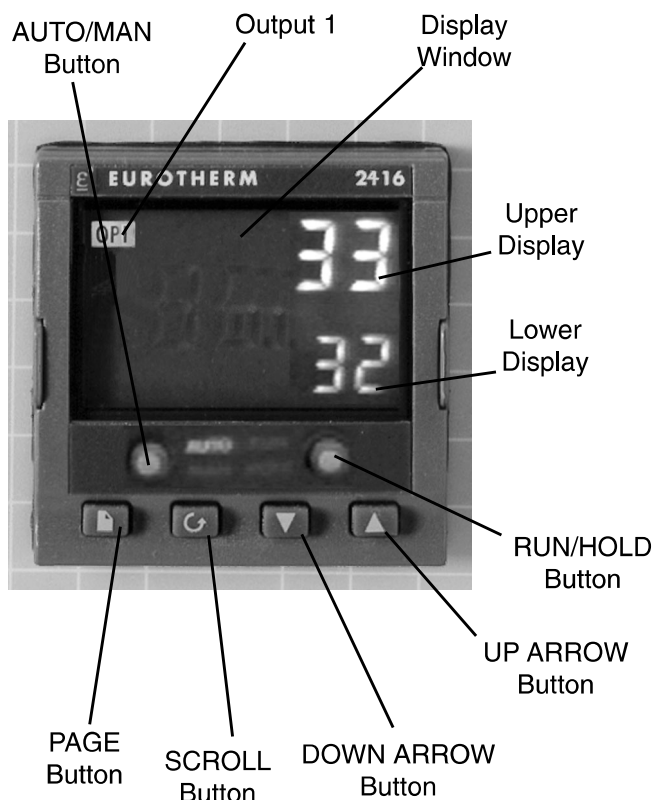

Basic Operation

When the controller is turned ON, it will perform a short self-test and then change to the HOME DISPLAY. The HOME DISPLAY shows the measured temperature (process value) in the upper display and the desired value (setpoint) in the lower display.

To Change the Setpoint

If you want to change the setpoint, press the UP or DOWN button until the desired setpoint value is displayed in the lower display and then release the button.

To View Display Units

From the HOME DISPLAY press the SCROLL button. The display will briefly show the temperature units in °C/F/K and then return to the HOME DISPLAY. (If you require a different temperature unit call Barnstead|Thermolyne Customer Service.)

To View the % Output Power

From the HOME DISPLAY press the SCROLL button twice. This value is a read-only value and cannot be changed.

Buttons and Indicators

OP1 (Output 1): illuminates when the heating output of the temperature controller is on.

AUTO/MAN: (Auto/Manual Mode): when the controller is in the automatic mode the output automatically adjusts to keep the temperature or process value at the setpoint. The “AUTO” light will illuminate. The manual mode has been disabled through factory configuration. Call Customer Service for further information.

RUN/HOLD (Run/Hold button):

- Starts a program when pressed once—RUN light illuminates.

- Holds a program when pressed again—HOLD light illuminates.
- Cancels hold and continues running when pressed again—HOLD light is off and RUN light illuminates.
- Exits a program when the button is held down for two seconds—RUN and HOLD lights are off.
- At the end of a program the RUN light will flash.
- During holdback the HOLD light will flash.

PAGE button: allows you to choose a parameter from a list of parameters.

SCROLL button: allows you to choose a parameter within a list of parameters.

UP button: allows you to increase the value in the lower display.

DOWN button: allows you to decrease the value in the lower display.

Controller Parameters

Home Display

°C: measured temperature in Celsius.

Temperature units can not be changed without entering the configuration. Contact Customer Service if a different temperature unit is required.

OP: % output power demand; displayed in lower display (cannot be changed).

C.id: Controller identification number.

PrG: Program number (displayed when a program is running; 4x16 programmable models only.)

IdHi: Deviation High Alarm

tunE: One-shot autotune enable.

run LiSt (Program Run List)

PrG: Currently running program (only used on 4x16 programmable models)

StAt: Displays the program status [OFF, run (running active program), hoLd (program on hold), HbAc (waiting for process to catch up), End (program completed)] in the lower display. The controller will default to “OFF.”

FASt: Fast run through program (no/YES). The controller will default to “no.”

SEG.d: Flash active segment type in the lower display of the home display (no/YES). The controller will default to “no.”

ProG LiSt (Program Edit List)

PrG.n: Press the UP or DOWN ARROW to select the program number (program number will be displayed in lower display on 4x16 programmable models only.)

Hb: Press the UP or DOWN ARROW to select the holdback type [OFF (disables holdback), Lo (deviation low holdback), Hi (deviation high holdback) or bAnd (deviation band holdback)] for the entire program. The controller will default to “OFF.”

Hb.U: Press the UP or DOWN ARROW to select the holdback value (in display units).

rmP.U: Press the UP or DOWN ARROW to toggle between ramp units (SEc, min or Hour). Controller will default to “SEc.”

dwL.U: Press the UP or DOWN ARROW to toggle between dwell units (SEc, min or Hour). Controller will default to “SEc.”

Cyc.n: Press the UP or DOWN ARROW to set the number of program cycles (1 to 999 or cont). The controller will default to “cont.”

SEG.n: Press the UP or DOWN ARROW to select the segment number (1-8 in 8 segment models, 1-16 in 4x16 models).

tYPE: Press the UP or DOWN ARROW to select the segment type [End (end of program), rmP.r = ramp rate (ramp to a specified setpoint at a set rate), rmp.t = ramp time (ramp to a specified temperature in a set time), dwELL (to maintain a constant temperature for a set time), StEP (climb instantaneously from current to specified temperature), cALL (to call a program as a subroutine, available only on 4x16 programmable models)]. The controller will default to “End.” Other parameters used with tYPE include; tGt target setpoint), Rate (rate of temperature increase) and dur (time to target setpoint or time to dwell).

End.t: End segment type: dwELL (dwell continuous), rSEt (reset) and S OP (End Segment Output power level).

AL LiSt (Alarm List)

ldHi: Deviation High Alarm.

Atun LiSt: (Autotune List)

tunE: One-shot autotune enable.

drA: Adaptive tune enable.

drA.t: Adaptive tune trigger level in display units. Range = 1 9999.

Pid LiSt

G.SP (Gain Setpoint): Is the temperature at which the controller switches from the (SEt1) PID values to the (SEt 2) PID values.

Pb: Proportional band in display units. (SEt 1)

ti: Integral time in seconds. (SEt 1)

td: Derivative time in seconds. (SEt 1)

Pb2: Proportional band. (SEt 2)

ti2: Integral time in seconds. (SEt 2)

td2: Derivative time in seconds. (SEt 2)

ACCS LiSt (Access List)

Access Code (Code needed to enter or change the other configuration parameters which are not normally accessible.) Not accessible.



Note

The following alarm messages are factory default settings and may vary if you have changed the configuration of your controller:

IDHi: = 50°C

2FSH: = 1225°C

Alarms

The controller will flash an alarm message in the home display if an alarm condition is detected.

IdHi: PV deviation high alarm.

2FSH: PV full scale high alarm.

LCr: load current low alarm.

HCr: load current high alarm.

S.br: Sensor break: check that sensor is connected correctly.

L.br: Loop Break: Check that the heating circuits are working properly.

Ld.F: Heater Circuit Fault: indication of either an open or short solid state relay, a blown fuse, missing supply or open circuit heater.

SSr.F: Solid state relay failure indications in a solid state relay: indicates either an open or short circuit in the SSR.

Htr.F: Heater failure: Indication that there is a fault in the heating circuit: indicates either a blown fuse, missing supply or open circuit heater.

Sensor Break Protection

This controller provides sensor break protection in the event the thermocouple opens. If an open thermocouple condition occurs, the digital display will Blink "S.br" and the power to the heating element will be shut OFF (Cycle light will extinguish).

Over-Temperature Protection (OTP)

The OTP will be in effect during any alarm condition when the temperature of the furnace has deviated beyond the limit. The "Deviation

High” alarm is the only alarm value which can be changed. To change it, press the SCROLL button until “idHI” appears on the display. Press the UP or DOWN button to select the OTP value you desire. We recommend a value of 20° above your working temperature to provide protection for your workload.

To Operate the Controller as a Single Setpoint Controller

1. Switch the circuit breaker to the “ON” position. The setpoint temperature presently set in the controller will appear in the lower display. (The upper display indicates the actual chamber temperature.)
2. To change the setpoint, press the UP or DOWN button until the desired setpoint value is displayed; then release the button.
3. The furnace will begin to heat if the new setpoint temperature is higher than the present chamber temperature.

Programming the Controller

The controller is capable of varying temperature or process value with time through programming. A program is stored as a series of segments and can be run once, repeated a set number of times or run continuously. To create a customized program using the controller parameters listed under “Controller

Parameters” at the beginning of this section, follow the procedures outlined in the preceding sections of this manual.

Creating a New Program or Editing an Existing Program (4x16 Segment Programmable Models Only)

The same steps are used when creating a new program and editing an existing program with the exception being that a new program starts with all its segments set to End in the tYPE parameter. Temporary changes can be made to these parameters when the program is in the hold state but permanent changes must be made in the reset state. Follow the steps below to create or edit a program.

1. Press the PAGE button until you reach the program list (ProG LiSt).
2. Press the SCROLL button until display reads, “PrG.n.”
3. Press the UP or DOWN button to select a number for a new program or to edit an existing program.

Hb: Holdback

Holdback consists of a value and a type. If the measured value lags behind the setpoint by an undesirable amount during a ramp or dwell, the holdback feature can be used to freeze the program at its current state (the HOLD light will flash). The program will resume when the error comes within the holdback value.

OFF: holdback is disabled.

Lo (Deviation Low Holdback): holds the program back when process variable deviates below the setpoint by more than the holdback value.

Hi (Deviation High Holdback): holds the program back when process variable deviates above the setpoint by more than the holdback value.

bAnd (Deviation Band Holdback): combines the features of the high and low deviation holdback in that it holds the program back when the process variable deviates above or below the setpoint by more than the holdback value.



Note

The value set in this parameter is always for the entire program.

To set the holdback type:

1. Press the PAGE button until you reach the program list (ProG LiSt).
2. Press the SCROLL button until display reads, "Hb."
3. Press the UP or DOWN button to toggle between "bAnd, Hi, Lo and OFF."

Hb U: Holdback Value

To set the holdback value:

1. Press the PAGE button until you reach the program list (ProG LiSt).
2. Press the SCROLL button until display reads, "Hb.U."
3. Press the UP or DOWN button to enter a holdback value.

rmP.U: Setting Ramp Units

Ramp units are time units which are used in

“rmP.r” segments (ramp to a setpoint at degrees per second, minute or hour) and “rmP.t” segments (ramp to setpoint in a specific amount of time). See “Setting the Segment Type” for an explanation on how to set a ramp segment.

1. Press the PAGE button until you reach the program list (ProG LiSt).
2. Press the SCROLL button until display reads, “rmP.U.”
3. Press the UP or DOWN button to toggle between seconds, minutes and hours.

dwL.U: Setting Dwell Units

Dwell units are time units which are used in “dwELL” segments (amount of time to remain at a specific temperature). See “Setting the Segment Type” for an explanation on how to set a dwell segment.

1. Press the PAGE button until you reach the program list (ProG LiSt).
2. Press the SCROLL button until display reads, “dwL.U.”
3. Press the UP or DOWN button to toggle between seconds, minutes and hours.

CYC.n: Setting the Number of Cycles

Set the number of times a group of segments or programs are to be repeated by following the steps listed below.

1. Press the PAGE button until you reach the program list (ProG LiSt).

2. Press the SCROLL button until display reads, "CYC.n."
3. Press the UP or DOWN button to select the number of cycles you want to run or, press the DOWN button to select "cont." so the program will run continuously.

**Note**

The program ramp rate is designed to reduce the heatup rate or cooling rate that the furnace normally exhibits. When not using this feature, the furnace will operate at its maximum heating and cooling capability.

**Note**

When the program ramp has ended or has been reset, the furnace will continue to maintain setpoint temperature. It will not cool to ambient temperature unless the setpoint is set to ambient temperature by the program or by the operator.

Setting the Segment Type

There are five segment types. Proceed with the following steps according to the type of segment you have selected.

rmP.r (Ramp)

To ramp linearly at a set rate to a specified temperature:

1. Press the PAGE button until you reach the program list (ProG LiSt).
2. Press the SCROLL button until display reads, "tYPE."
3. Press the UP or DOWN button until display reads, "rmP.r."

Steps 4 and 5 are used in the 4 program model only. If you are using an 8 segment program, skip to step 6.

4. Press the SCROLL button until display reads "Hb."
5. Press the UP or DOWN button to toggle between "bAnd, Hi, Lo and OFF."
6. Press the SCROLL button until display reads, "tGt."
7. Press the UP or DOWN button to set a target setpoint.
8. Press the SCROLL button until display

reads, "rAtE."

9. Press the UP or DOWN button to select a value in ramp units (seconds, minutes or hours; set in the "rmP.U" parameter).

rmP.t

To ramp to a specified temperature at a set time:

1. Press the PAGE button until you reach the program list (ProG LiSt).
2. Press the SCROLL button until display reads, "tYPE."
3. Press the UP or DOWN button until display reads, "rmP.t."
4. Press the SCROLL button until display reads, "tGt."
5. Press the UP or DOWN button to set a target setpoint.
6. Press the SCROLL button until display reads, "dur."
7. Press the UP or DOWN button to select a time in ramp units (seconds, minutes or hours; set in the "rmP.U" parameter).

dwEII

To maintain a constant temperature for a specified time:

1. Press the PAGE button until you reach the program list (ProG LiSt).
2. Press the SCROLL button until display reads, "tYPE."
3. Press the UP or DOWN button until display reads, "dwEII."

4. Press the SCROLL button until display reads, “dur.”
5. Press the UP or DOWN button to select a time in dwell units (seconds, minutes or hours; set in the “dwL.U” parameter).

StEP

To climb instantaneously from the current temperature to a specified temperature.

1. Press the PAGE button until you reach the program list (ProG LiSt).
2. Press the SCROLL button until display reads, tYPE.”
3. Press the UP or DOWN button until the display reads, “StEP.”
4. Press the SCROLL button until display reads, “tGt.”
5. Press the UP or DOWN button to set a target setpoint.

cALL (Running Multiple Programs; 4x16 Segment Programmable Models Only)

To call a program as a subroutine:

If you want to run multiple programs, you can program the controller to “call” or link one program to another. This makes it possible to run one program at any time during another program and also return to the original program if desired.

1. Press the PAGE button until you reach the program list (ProG LiSt).
2. Press the SCROLL button until display reads, “tYPE.”

3. Press the UP or DOWN button until display reads, "cALL."
4. Press the SCROLL button until display reads, "PrG.n."
5. Press the UP or DOWN button to select a program number to be linked.
6. Press the SCROLL button until display reads, "CYC.n."
7. Press the UP or DOWN button to select the number of cycles the linked program is to be run.

End

To end or repeat a program:

1. Press the PAGE button until you reach the program list (ProG LiSt).
2. Press the SCROLL button until display reads, "tYPE."
3. Press the UP or DOWN button until display reads, "End."
4. Press the SCROLL button until display reads, "End.t."
5. Press the UP or DOWN button to toggle between "dWEll" (an indefinite dwell), "S OP" (End Segment Output Power) and "rSET" (reset).

Setting the Target Setpoint (4x16

Segment Programmable Models Only)

1. Press the PAGE button until you reach the program list (ProG LiSt).

2. Press the SCROLL button until display reads, "tGt."
3. Press the UP or DOWN button to set the target setpoint temperature.

Running a Program (8 Segment Programmable Models)

To run a program, press the RUN/HOLD button. (The RUN light will illuminate.)

Running a Program (4x16 Segment Programmable Models)

To run a program, press the RUN/HOLD button. (The RUN light will illuminate) or:

1. Press the PAGE button until you reach the run list (run LiSt).
2. Press the SCROLL button until display reads, "PrG."
3. Press the UP or DOWN button to select the program number you want to run.
4. Press the RUN/HOLD button once to start the program. (The RUN light will illuminate.)



Note

Display will flash “tu.ER” if an error occurs during tuning. To clear the error and restart tuning, simultaneously press the PAGE and SCROLL buttons and follow the steps outlined in “Autotuning.”



Note

To stop the tuning function, simultaneously press the PAGE and SCROLL buttons.

Holding a Program

To put a running program on hold, press the RUN/HOLD button. (The HOLD light will illuminate.)

Cancelling a Program

To cancel a program, hold the RUN/HOLD button down until the RUN and HOLD lights go off.

Tuning your Furnace

The purpose of tuning your furnace is to match the characteristics of your controller to the characteristics of the process being controlled. Good control is evidenced by: stable, straight-line control of the setpoint temperature with no fluctuations; No overshoot or undershoot of the setpoint temperature; rapid restoration of the setpoint temperature when external disturbances cause deviations from the setpoint.

This controller has automatic tuning features which install optimum tuning parameters to give the best temperature accuracy. No manual loading of tuning parameters is needed. We recommend that you tune the furnace to your specific application to obtain the best results. To provide the best temperature accuracy possible, use these features when you install your furnace and whenever you change your application or procedure.

Tuning Error

The display will flash “tu.ER” if an error occurs during tuning. To clear the error and restart tuning, simultaneously press the PAGE and SCROLL buttons and follow the steps outlined in “Autotuning.”

Gain Scheduling

G.SP: Gain Scheduling

Gain scheduling is the automatic transfer of control between two sets of PID values. The 2416 controller does this at a presettable process value. Gain scheduling is used for difficult control processes which show large changes in their response time or sensitivity at high or low temperatures, or when heating or cooling.

The G.SP gain schedule setpoint is factory set at 700° C. The G.SP must be adjusted to 200°C from the desired setpoint temperature when tuning.

Setting the Transfer Point

If gain scheduling has been enabled, "G.SP" will appear at the top of the PID list. This sets the value at which the transfer will occur. When the process value is below this level, PID1 will be active and when it is above, Pid2 will be active. Set a value between the control regions that show the greatest change to achieve the best point of transfer.

Tuning

The two sets of PID values can be manually set or automatically tuned. To tune automatically you must tune above and below the transfer point G.SP. If the process value is below the transfer point G.SP, the calculated values will automatically be inserted into the (SEt 1) set and if the process value is above G.SP, the calculated values will automatically be inserted into the (SEt 2).

Autotuning

The Autotune feature automatically sets up the PID values in the control parameters to suit new process conditions.

To tune your furnace using autotuning:

1. Load your furnace with a load similar to your normal load and close the door.
2. Set the setpoint temperature.
3. Press the PAGE button until the display reads, "Atun LiSt."
4. Press the SCROLL button until "tunE OFF" is displayed.
5. Press the UP or DOWN button to select "on."
6. Simultaneously press the PAGE and SCROLL buttons to return to the HOME DISPLAY. The display will flash "tunE" while tuning is in progress.

Adaptive Tuning

Adaptive tuning continuously evaluates tuning parameters. Adaptive tuning automatically installs new values if better accuracy is possible. Adaptive tuning should be used when the characteristics of a process change due to load or setpoint changes or, in a process that can not handle the oscillation caused by a one-shot tune.

To tune your furnace using adaptive tuning:

1. Load your furnace with a load characteristic of those you intend to heat in it.
2. Press the PAGE button until display

reads, "Atun LiSt."

3. Press the SCROLL button until "drA OFF" is displayed.
4. Press the UP or DOWN button to select "on."
5. Press the SCROLL button until "drA.t" is displayed.
6. Press the UP or DOWN button until the desired trigger value is achieved.

Furnace Loading



Caution

Do not overload your furnace chamber. If the load is to be heated uniformly, it should not occupy more than two-thirds of the furnace chamber. Maintain at least a 3/4" gap between the load and elements. Failure to observe this caution could result in damage to the furnace components.

- For best results, use only the center two-thirds of the furnace chamber.
- If you are heating a number of small parts, spread them throughout the center two-thirds of the furnace chamber.
- Keep objects away from the thermocouple.
- Use insulated tongs and mittens when loading and unloading the furnace.
- Always wear safety glasses.
- Never come into contact with the heating elements. Hitting the elements with tongs or laying the load against them will cause the elements to burn out prematurely.

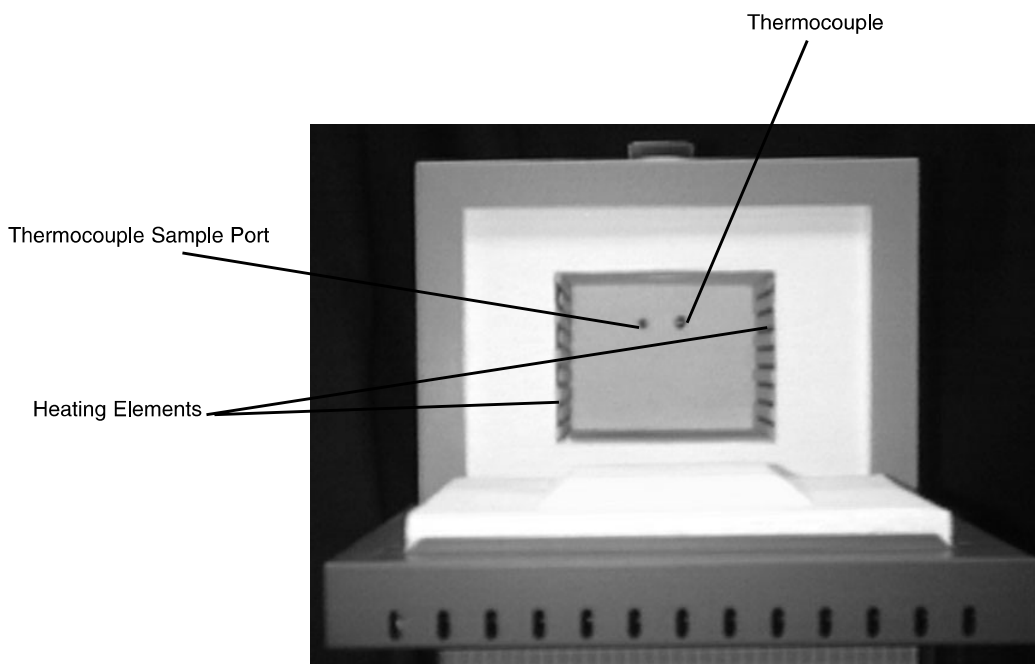

Preventive Maintenance

This unit is equipped with a venting system on the top of the furnace. This is for the removal of fumes from the chamber of the unit.

Contamination is a major cause of element failure, therefore, remove all fume forming material before heating. (e.g. clean cutting oil from tool steel).

Housekeeping is vital to your electric furnace – KEEP IT CLEAN. Run your furnace up to 871°C (1600°F) empty occasionally to burn off the contamination that may exist on the insulation and elements. Maintain 871°C (1600°F) for at least 4 hours to ensure complete ashing of foreign materials.

Element life is reduced somewhat by repeated heating and cooling. If the furnace is to be used again within a few hours, it is best to keep it at the operating temperature or at a reduced level such as 260°C (500°F). We highly recommend that you replace the thermocouple periodically (once every six months) to ensure temperature accuracy.

General Cleaning Instructions

Wipe exterior surfaces with a lightly dampened cloth containing a mild soap solution.

Troubleshooting

The Troubleshooting section is intended to aid in defining and correcting possible service problems. When using the chart, select the problem category that resembles the malfunction. Then proceed to the possible causes category and take necessary corrective action.

Problem	Possible Causes	Corrective Action
Cycle light does not illuminate.	The furnace is not connected to power supply.	Reconnect furnace to power supply.
	Incorrect power source.	Connect to correct power source.
	ON and OFF power switch defective.	Replace power switch.
	Defective cycle light.	Replace cycle light.
	Door switch malfunction.	Realign or replace furnace door safety switch.
Furnace does not heat.	No power.	Check power source and fuses or breakers.
	Defective electrical hookup.	Repair electrical hookup.
	Thermocouple has oxidized and opened the circuit.	Replace thermocouple.
	Controller malfunction.	Replace controller.
	Heating elements burned out.	Replace defective elements.
	Door switch malfunction.	Realign or replace door safety switch.
	Defective OTP relay.	Replace relay.
Defective solid state relay.	Replace relay.	

TROUBLESHOOTING

Door switch does not cut power to heating elements.	Door switch not functioning.	Realign or replace door safety switch.
Controller over-temp. does not cut power to furnace chamber.	Alarm output device malfunction.	Replace controller.
	OTP relay malfunction.	Replace relay.
	Element shorted to ground.	Replace faulty element.
Slow heatup.	Low line voltage.	Install line of sufficient size and voltage (isolate furnace from other electrical loads).
	Heavy load in chamber.	Lighten load in chamber to allow heat to circulate.
	Wrong heating element.	Install proper element.
	Heating element burned out.	Replace element.
Repeated element burnout.	Overheating furnace.	Keep furnace under maximum temperature. Closer supervision of control setting.
	Heating harmful materials.	Enclose material in container. Clean up spills in and on chamber. Ventilate chamber by leaving top vent slightly open when heating known harmful reagents.
	Contamination from previous burnout.	Replace insulation material.

Inaccurate temp. readout.	Oxidized or contaminated thermocouple.	Replace thermocouple.
	Poor thermocouple connection.	Tighten connections.
	Improper loading procedures.	Use proper loading procedures.
	Poor ventilation of control.	Clear area around furnace control.
	Thermocouple connections reversed.	Reconnect thermocouple correctly.

Maintenance and Servicing



Warning

To avoid electrical shock, this furnace must always be disconnected from the power supply prior to maintenance and service.

Perform only maintenance described in this manual. Contact an authorized dealer or our factory for parts and assistance.

Refer servicing to qualified personnel.



Note

The ceramic hearth collar may crack. This is a normal condition and will not affect the performance of the hearth collar.

To Replace a Heating Element

1. Disconnect the furnace from the power supply.
2. Remove the back terminal cover of the furnace. (Note placement and connection of wires.)
3. Loosen the nuts on the terminal points of the four heating element lead wires and remove the element wires from the terminals.
4. Loosen the thermocouple hold-down clip and carefully remove the thermocouple from the rear of the furnace chamber.
5. Remove both the back of the furnace and the blanket insulation.
6. Grasp the element lead wires and pull out both elements and the back chamber insulation.
7. Replace the defective element.
8. Reverse the disassembly procedure, making sure you thread all element lead wires through the insulating porcelain bushings on the back of the furnace and cut off any excess element lead wire after securing the leads to the terminal points.
9. Reconnect the furnace to the power supply.
10. Test the operation of the furnace.

To Replace a Chromel/Alumel Thermocouple (All Furnaces)

1. Disconnect the furnace from the power supply.
2. Remove both back covers. (Note placement and connection of wires.)
3. Remove the clip holding the thermocouple in place (1 screw), and remove the two screws on the thermocouple terminals.
4. Remove the thermocouple. (Note: first pull the thermocouple straight out of the hole in the chamber to avoid damage to the insulation.)
5. Guide the looped ends of the new thermocouple through the plastic bushings with the red (-) lead to the right as you face the back of the furnace.
6. Insert the thermocouple straight through the hole in the chamber.
7. Secure the thermocouple with clip and screw. Connect the looped ends of the thermocouple to the terminals with “+” to “+” (yellow) and “-” to “-” (red) wires. A polarity test of the thermocouple and lead wire is easily made with the use of a magnet. On a Chromel/Alumel thermocouple and lead wire, the non-magnetic wire is positive (+) and the magnetic wire is negative (-).

8. Replace both back covers.
9. Reconnect to the power supply.
10. Test the operation of the furnace.

To Replace Door Switches (Micro-Switch)

1. Disconnect the furnace from the power supply.
2. Remove the screws on the front dial and the screws and lock washers on the back cover.
3. Slide the control section forward. (Note: do not pull excessively on the internal wires.)
4. Disconnect the wires from the door switch. (Note the connection placement of the wires to the micro-switch.)
5. Remove the screws and nuts from the micro-switch.
6. Insert new micro-switches and secure with the screws and nuts removed in step 5.
7. Reconnect the wires to the new door switch.
8. To realign the door switches, see the following section, "To Realign Door Switches."
9. Slide the control section back and replace the screws and lock washers

described in step 2.

10. Reconnect to the power supply.
11. Test the operation of the door switches. (See next section, step 8.)

To Realign Door Switches (Micro-Switch):

1. Disconnect the furnace from the power supply.
2. Remove the lower rear cover.
3. With the door closed, loosen the screws on the micro-switch bracket and gently push the switch bracket forward until you hear a click.
4. Open and close the door; the switch should click when the door is opened approximately 3" and 1" to 2" before the door is closed. Slide the switches backward to increase the distance, forward to decrease the distance.
5. Tighten the two screws to secure the switches. Check the operation of the switch as described in step 4 after tightening the screws.
6. Replace the back cover.
7. Reconnect to power supply.
8. To test the operation of the door switch: move the power switch on, set the control to a setting high enough to keep the control from cycling, open

and close the door; the cycle light should turn OFF when the door is opened approximately 3" and turn back ON 1" to 2" before the door is closed.

To Replace the Controller

The controller plugs into a panel mounting sleeve which should be left permanently installed in the furnace housing. To remove the controller, release the side clips and slide the controller out. Do not attempt to dismantle this unit further; replace it with a Thermolyne loaner or a new unit.

Replacement Parts



Warning

Replace fuses with same type and rating.

Single Setpoint Models

F47910, F47910-26, F47910-33, F47914, F47915, F48010, F48010-26, F48010-33, F48014, F48015, F48015-60, F48018

<u>Part number</u>	<u>Description</u>	<u>QTY.</u>	<u>Notes</u>
CN71X96	Controller	1	F48010-33 only
CN71X73	Controller	1	All Models except F48010-33
CAX94	Line Filter	1	"-33" models only.
EL479X1A	Element	2	120 & 240 volt F47900 models only.
EL479X2A	Element	2	100 volt F47900 models only.
EL480X1A	Element	2	120 & 240 volt F48000 models only, except "-33" models.
EL480X2A	Element	2	100 & 208 volt F48000 models only.
EL1205X1	Element	2	"-33" F48000 models only.
FZX30	Line Fuse	2	"-33" models only.
PLX76	Pilot Light	1	100 & 120 volt models only.
PLX82	Pilot Light	1	208 & 240 volt models only.
RYX34	S.S. Relay	1	All Models
SWX163	Door Switch	2	All Models
SWX143	Power Switch	1	100 & 120 volt models only
SWX144	Power Switch	1	208 & 240 volt models only.
TRX136	Terminal Block	1	All Models
TC1165X1	Thermocouple	1	All Models

Single Setpoint Models with OTP

F47920, F47920-26, F47920-33, F47924, F47925, F48020, F48020-26, F48020-33, F48024, F48025, F48025-60, F48028

<u>Part number</u>	<u>Description</u>	<u>QTY.</u>	<u>Notes</u>
CN71X100	Controller	1	F48020-33 only
CN71X99	Controller	1	All Models except F48020-33
CAX94	Line Filter	1	"-33" models only.
EL479X1A	Element	2	120 & 240 volt F47900 models only.
EL479X2A	Element	2	100 volt F47900 models only.
EL480X1A	Element	2	120 & 240 volt F48000 models only, except "-33" models.
EL480X2A	Element	2	100 & 208 volt F48000 models only.
EL1205 X1	Element	2	"-33" F48000 models only.
FZX30	Line Fuse	2	"-33" models only.
PLX76	Pilot Light	1	100 & 120 volt models only.
PLX82	Pilot Light	1	208 & 240 volt models only.
RYX34	S.S. Relay	1	All Models
RYX56	Mechanical Relay	1	100 & 120 volt models only.
RYX57	Mechanical Relay	1	208 & 240 volt models only.
SWX163	Door Switch	2	All Models
SWX143	Power Switch	1	100 & 120 volt models only
SWX144	Power Switch	1	208 & 240 volt models only.
TRX136	Terminal Block	1	All Models
TC1165X1	Thermocouple	1	All Models

REPLACEMENT PARTS

8 Segment Programmable Models with OTP

F47920-80, F47920-26-80, F47920-33-80, F47924-80, F47925-80, F48020-80, F48020-26-80, F48020-33-80, F48024-80, F48025-80, F48025-60-80, F48028-80

<u>Part number</u>	<u>Description</u>	<u>QTY.</u>	<u>Notes</u>
CN71X97	Controller	1	-33 models only
CN71X74	Controller	1	All models except -33 models
CAX94	Line Filter	1	"-33" models only.
EL479X1A	Element	2	120 & 240 volt F47900 models only.
EL479X2A	Element	2	100 volt F47900 models only.
EL480X1A	Element	2	120 & 240 volt F48000 models only, except "-33" models.
EL480X2A	Element	2	100 & 208 volt F48000 models only.
EL1205X1	Element	2	"-33" F48000 models only.
FZX30	Line Fuse	2	"-33" models only.
PLX76	Pilot Light	1	100 & 120 volt models only.
PLX82	Pilot Light	1	208 & 240 volt models only.
RYX34	S.S. Relay	1	All Models
RYX56	Mechanical Relay	1	100 & 120 volt models only.
RYX57	Mechanical Relay	1	208 & 240 volt models only.
SWX163	Door Switch	2	All Models
SWX143	Power Switch	1	100 & 120 volt models only
SWX144	Power Switch	1	208 & 240 volt models only.
TRX136	Terminal Block	1	All Models
TC1165X1	Thermocouple	1	All Models

4 X 16 Segment Programmable Models with OTP

F47950, F47950-26, F47950-33, F47954, F47955, F48050, F48050-26, F48050-33, F48055, F48055-60, F48058

<u>Part number</u>	<u>Description</u>	<u>QTY.</u>	<u>Notes</u>
CN71X98	Controller	1	-33 models only
CN71X75	Controller	1	All models except -33 models
CAX94	Line Filter	1	"-33 models only.
EL479X1A	Element	2	120 & 240 volt F47900 models only.
EL479X2A	Element	2	100 volt F47900 models only.
EL480X1A	Element	2	120 & 240 volt F48000 models only, except "-33" models.
EL480X2A	Element	2	100 & 208 volt F48000 models only.
EL1205X1	Element	2	"-33" F48000 models only.
FZX30	Line Fuse	2	"-33" models only.
PLX76	Pilot Light	1	100 & 120 volt models only.
PLX82	Pilot Light	1	208 & 240 volt models only.
RYX34	S.S. Relay	1	All Models
RYX56	Mechanical Relay	1	100 & 120 volt models only.
RYX57	Mechanical Relay	1	208 & 240 volt models only.
SWX163	Door Switch	2	All Models
SWX143	Power Switch	1	100 & 120 volt models only
SWX144	Power Switch	1	208 & 240 volt models only.
TRX136	Terminal Block	1	All Models
TC1165X1	Thermocouple	1	All Models

Wiring Diagrams

SINGLE SETPOINT CONTROL

DIAGRAM COMPONENT LIST

REF. NO.	DESCRIPTION	MODEL NO. AND OUR PART NO.(S)	F47910-26	F47910-33	F47914	F47915
CN1	CONTROL	F47910	CN71X73	CN71X73	CN71X73	CN71X73
DS1	PILOT LIGHT	F47910	PLX104	PLX104	PLX103	PLX103
F1	FUSE	F47910	FZX30	FZX30		
F2	FUSE	F47910	CAX98	CAX98		
FL1	FILTER	F47910	EL479X1A	EL480X1A	EL479X2A	EL479X1A
H1	HEATING ELEMENT	F47910	EL479X1A	EL480X1A	EL479X2A	EL479X1A
H2	HEATING ELEMENT	F47910	EL479X1A	EL480X1A	EL479X2A	EL479X1A
RY1	RELAY, SOLID STATE	F47910	RYX34	RYX34	RYX34	RYX34
S1	SWITCH, POWER	F47910	SWX144	SWX144	SWX143	SWX143
S2	SWITCH, DOOR	F47910	SWX163	SWX163	SWX163	SWX163
S3	SWITCH, DOOR	F47910	SWX163	SWX163	SWX163	SWX163
TB1	TERMINAL BLOCK	F47910	TRX136	TRX136	TRX136	TRX136
TC1	THERMOCOUPLE	F47910	TC1165X1	TC1165X1	TC1165X1	TC1165X1

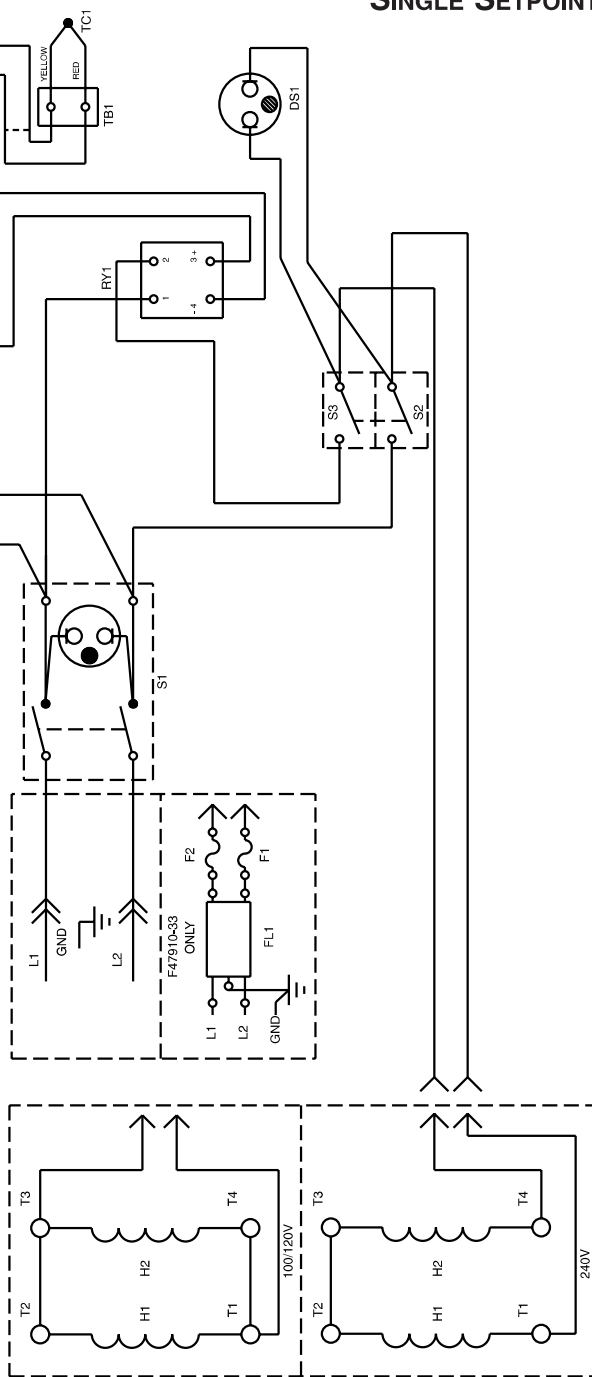

WIRING DIAGRAMS

SINGLE SETPOINT CONTROL W/OTP

DIAGRAM COMPONENT LIST

REF. NO.	DESCRIPTION	F47920	F47920-26	F47920-33	F47924	F47925
CNT	CONTROL	CN71X99	CN71X99	CN71X99	CN71X99	CN71X99
DS1	PILOT LIGHT, NEON	PLX82	PLX82	PLX82	PLX76	PLX76
F1	FUSE			FZX30		
F2	FUSE			FZX30		
FL1	FILTER, EMI			CAX94		
H1	HEATING ELEMENT	EL479X1A	EL479X1A	EL479X1A	EL479X2A	EL479X1A
H2	HEATING ELEMENT	EL479X1A	EL479X1A	EL479X1A	EL479X2A	EL479X1A
RY1	RELAY, DPST, N.O.	RXX57	RXX57	RXX57	RXX56	RXX56
RY2	SOLID STATE RELAY	RXX34	RXX34	RXX34	RXX34	RXX34
S1	SWITCH	SWX144	SWX144	SWX144	SWX143	SWX143
S2	DOOR SWITCH	SWX163	SWX163	SWX163	SWX163	SWX163
S3	DOOR SWITCH	SWX163	SWX163	SWX163	SWX163	SWX163
TB1	TERMINAL BLOCK	TRX136	TRX136	TRX136	TRX136	TRX136
TC1	THERMOCOUPLE	TC1165X1	TC1165X1	TC1165X1	TC1165X1	TC1165X1

WIRING DIAGRAM

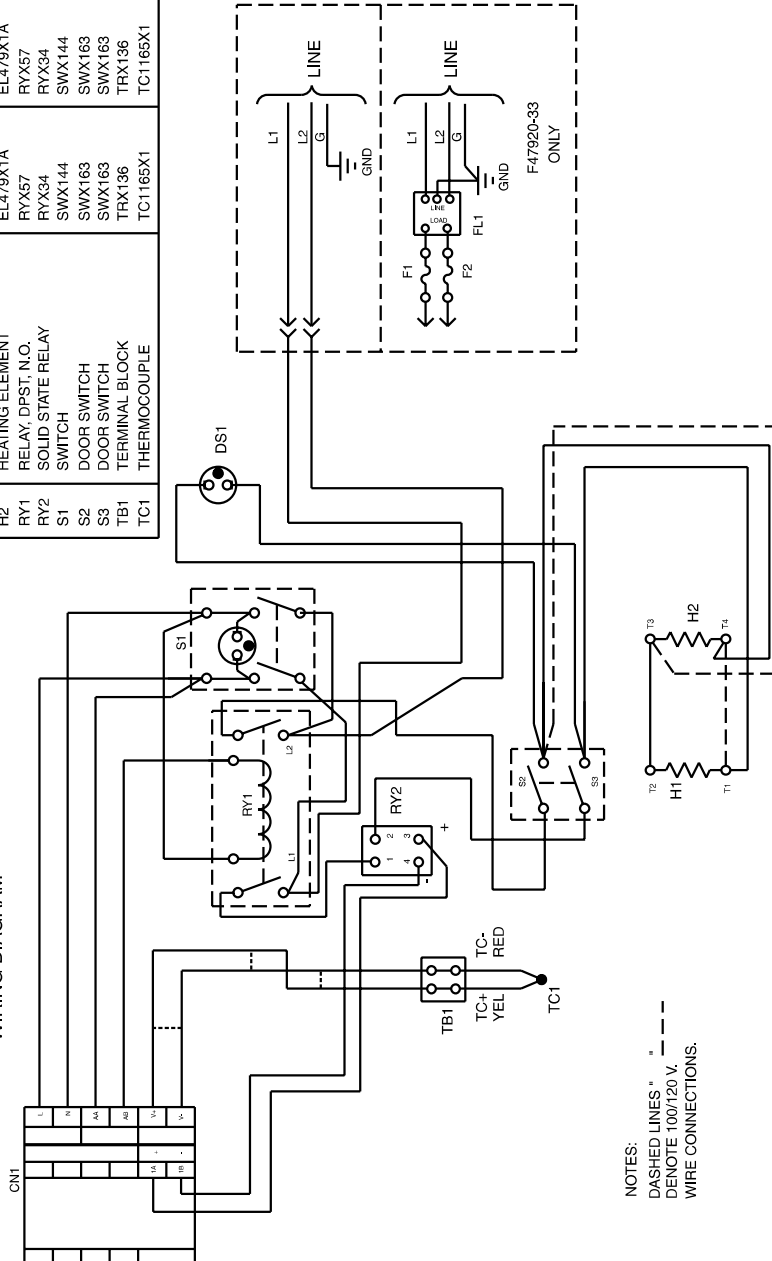

NOTES:
 DASHED LINES " " DENOTE 100/120 V.
 WIRE CONNECTIONS.

WIRING DIAGRAMS

8 SEGMENT PROGRAMMABLE CONTROL

WIRING DIAGRAM

DIAGRAM COMPONENT LIST

REF. NO.	DESCRIPTION	MODEL NO. AND OUR PART NO.(S)			
		F47920-80	F47920-26-80	F47920-33-80	F47924-80
GN1	CONTROL	GN71X74	GN71X74	GN71X74	GN71X74
DS1	PILOT LIGHT, NEON	PLX82	PLX82	PLX82	PLX76
F1	FUSE			FZX30	
F2	FUSE			FZX30	
FL1	FILTER, EMI			CAX94	
H1	HEATING ELEMENT	EL479X1A	EL479X1A	EL479X1A	EL479X2A
H2	HEATING ELEMENT	EL479X1A	EL479X1A	EL479X1A	EL479X2A
RY1	RELAY, DPST, N.O.	RYX57	RYX57	RYX57	RYX56
RY2	SOLID STATE RELAY	RYX34	RYX34	RYX34	RYX34
S1	SWITCH	SWX144	SWX144	SWX144	SWX143
S2	DOOR SWITCH	SWX163	SWX163	SWX163	SWX163
S3	DOOR SWITCH	SWX163	SWX163	SWX163	SWX163
TB1	TERMINAL BLOCK	TRX136	TRX136	TRX136	TRX136
TC1	THERMOCOUPLE	TC1165X1	TC1165X1	TC1165X1	TC1165X1

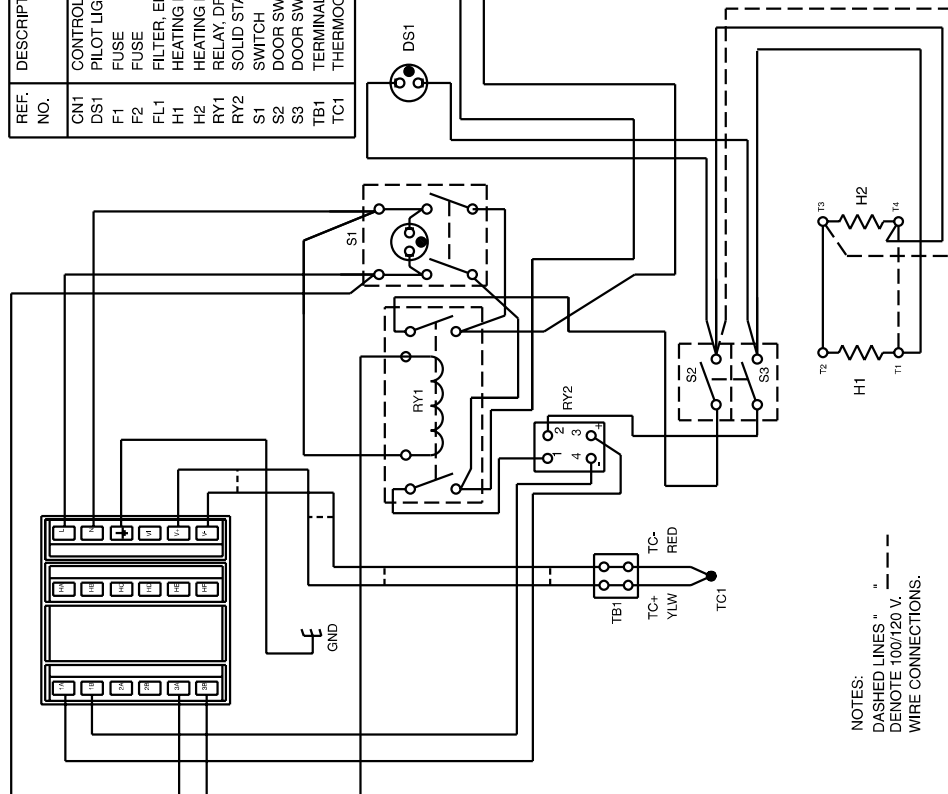

NOTES:
 DASHED LINES " " DENOTE 100/120 V. WIRE CONNECTIONS.

WIRING DIAGRAMS

4 x 16 SEGMENT PROGRAMMABLE CONTROL

DIAGRAM COMPONENT LIST

REF. NO.	DESCRIPTION	MODEL NO. AND OUR PART NO.(S)				
		F47950	F47950-26	F47950-33	F47954	F47955
CN1	CONTROL	CN71X75	CN71X75	CN71X75	CN71X75	CN71X75
DS1	PILOT LIGHT, NEON	PLX82	PLX82	PLX82	PLX76	PLX76
F1	FUSE			FZX30		
F2	FUSE			FZX30		
FL1	FILTER, EMI			CAX94		
H1	HEATING ELEMENT	EL479X1A	EL479X1A	EL479X1A	EL479X2A	EL479X1A
H2	HEATING ELEMENT	EL479X1A	EL479X1A	EL479X1A	EL479X2A	EL479X1A
RY1	RELAY, DPST, N.O.	RYX57	RYX57	RYX57	RYX56	RYX56
RY2	SOLID STATE RELAY	RYX34	RYX34	RYX34	RYX34	RYX34
S1	SWITCH	SWX144	SWX144	SWX144	SWX143	SWX143
S2	DOOR SWITCH	SWX163	SWX163	SWX163	SWX163	SWX163
S3	DOOR SWITCH	SWX163	SWX163	SWX163	SWX163	SWX163
TB1	TERMINAL BLOCK	TRX136	TRX136	TRX136	TRX136	TRX136
TC1	THERMAL COUPLE	TC1165X1	TC1165X1	TC1165X1	TC1165X1	TC1165X1

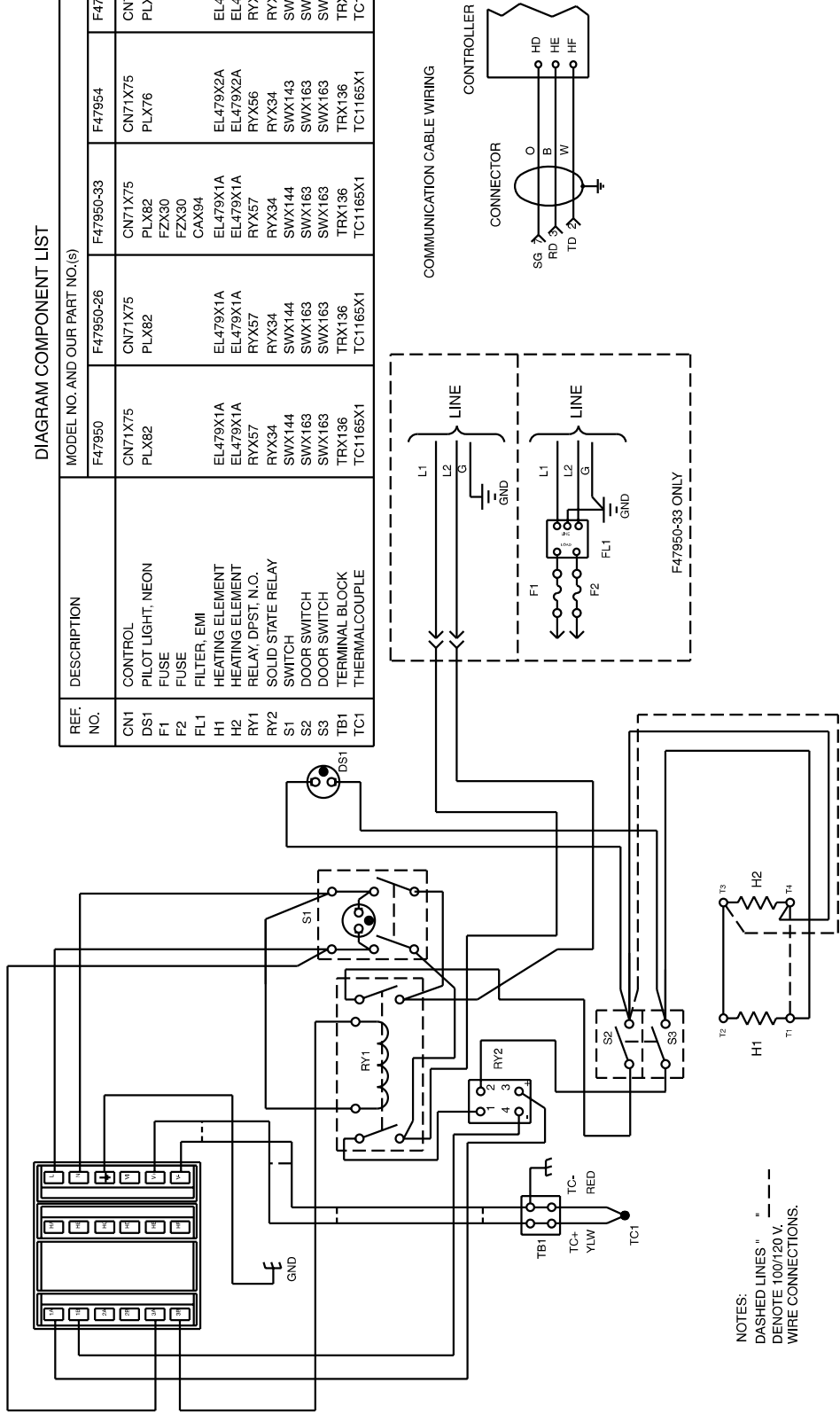

NOTES:
 DASHED LINES " " DENOTE 100/120 V. WIRE CONNECTIONS.

WIRING DIAGRAMS SINGLE SETPOINT CONTROL

DIAGRAM COMPONENT LIST

REF. NO.	DESCRIPTION	MODEL NO. AND OUR PART NO.(S)					
		F48010	F48010-26	F48010-33	F48014	F48015, F48015-60	F48018
CN1	CONTROL	CN71X73 PLX82	CN71X73 PLX82	CN71X96 PLX82 FZX30 FZX30 CAX98	CN71X73 PLX76	CN71X73 PLX76	CN71X73 PLX82
DS1	PILOT LIGHT	EL480X1A EL480X1A	EL480X1A EL480X1A	EL1205X1 EL1205X1	EL480X2A EL480X2A	EL480X1A EL480X1A	EL480X2A EL480X2A
F1	FUSE	RXX34	RXX34	RXX34	RXX34	RXX34	RXX34
F2	FUSE	SWX144	SWX144	SWX144	SWX143	SWX143	SWX144
FL1	FILTER	SWX163	SWX163	SWX163	SWX163	SWX163	SWX163
H1	HEATING ELEMENT	TRX136	TRX136	TRX136	TRX136	TRX136	TRX136
H2	HEATING ELEMENT	TC1165X1	TC1165X1	TC1165X1	TC1165X1	TC1165X1	TC1165X1
RY1	RELAY, SOLID STATE						
S1	SWITCH, DOOR						
S2	SWITCH, DOOR						
S3	SWITCH, DOOR						
TB1	TERMINAL BLOCK						
TC1	THERMOCOUPLE						

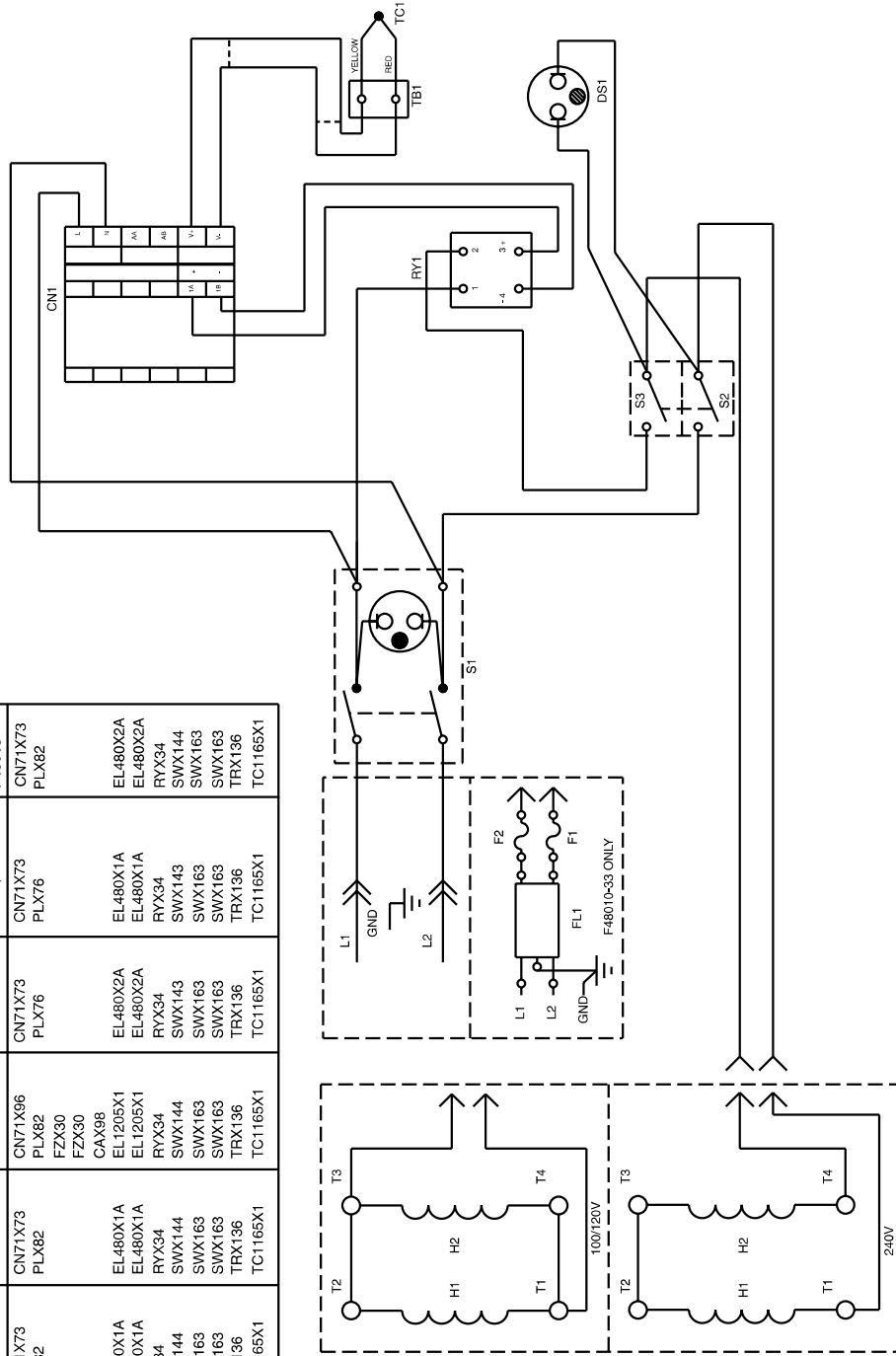

WIRING DIAGRAMS

SINGLE SETPOINT CONTROL W/OTP

DIAGRAM COMPONENT LIST

REF. NO.	DESCRIPTION	F48020	F48020-26	F48020-33	F48024	F48025, F48025-60	F48028
CN1	CONTROL	CN71X99	CN71X99	CN71X100	CN71X99	CN71X99	CN71X99
DS1	PILOT LIGHT, NEON	PLX82	PLX82	PLX82	PLX76	PLX76	PLX82
F1	FUSE			FZX30			
FL1	FILTER, EMI			CAX94			
H1	HEATING ELEMENT	EL480X1A	EL480X1A	EL1205X1	EL480X2A	EL480X1A	EL480X2A
H2	HEATING ELEMENT	EL480X1A	EL480X1A	EL1205X1	EL480X2A	EL480X1A	EL480X2A
RY1	RELAY, DPST, N.O.	RYX57	RYX57	RYX57	RYX56	RYX56	RYX57
RY2	SOLID STATE RELAY	RYX34	RYX34	RYX34	RYX34	RYX34	RYX34
S1	SWITCH	SWX144	SWX144	SWX144	SWX143	SWX143	SWX144
S2	DOOR SWITCH	SWX163	SWX163	SWX163	SWX163	SWX163	SWX163
S3	DOOR SWITCH	SWX163	SWX163	SWX163	SWX163	SWX163	SWX163
TB1	TERMINAL BLOCK	TRX136	TRX136	TRX136	TRX136	TRX136	TRX136
TC1	THERMOCOUPLE	TC1165X1	TC1165X1	TC1165X1	TC1165X1	TC1165X1	TC1165X1

WIRING DIAGRAM

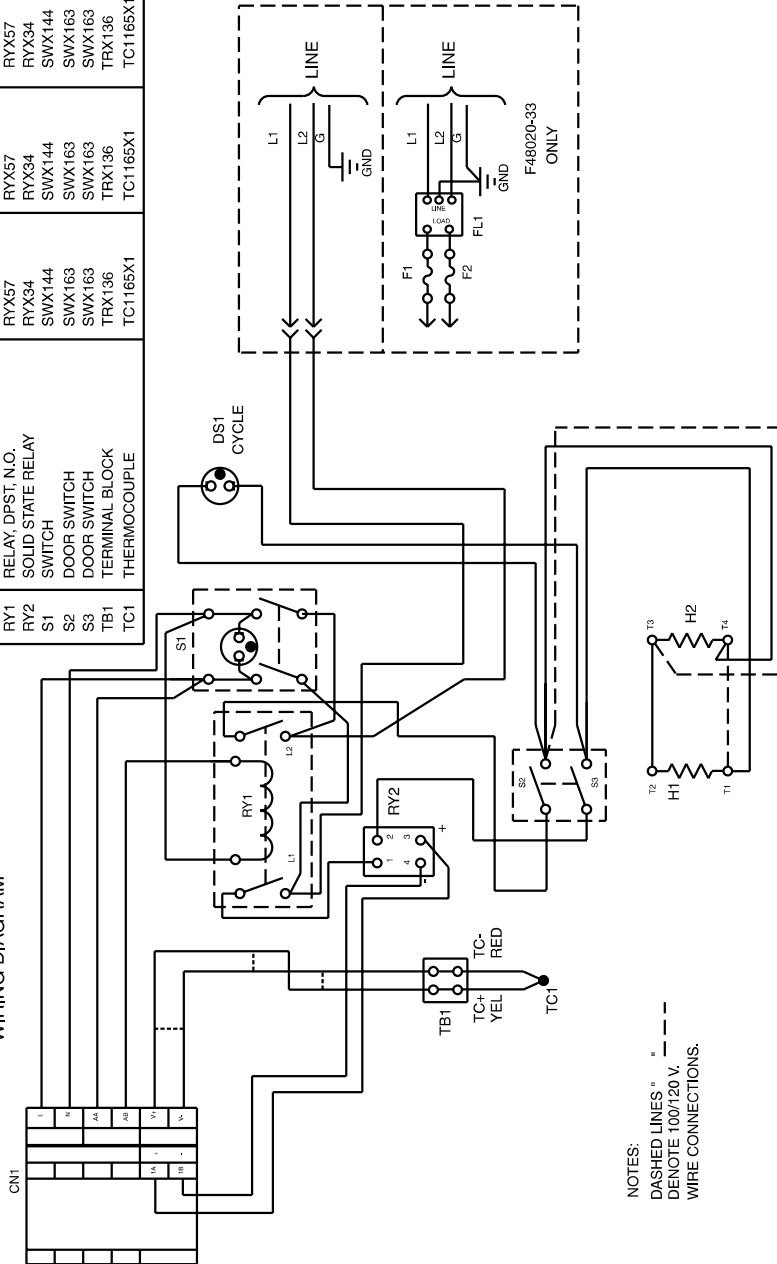

NOTES:
 DASHED LINES " " DENOTE 100/120 V. WIRE CONNECTIONS.

WIRING DIAGRAMS

8 SEGMENT PROGRAMMABLE CONTROL

WIRING DIAGRAM

DIAGRAM COMPONENT LIST

REF. NO.	DESCRIPTION	MODEL NO. AND OUR PART NO.(S)						
		F48020-80	F48020-26-90	F48020-33-90	F48024-80	F48025-80, F48025-60-80	F48028-80	
CN1	CONTROL	CN71X74	CN71X74	CN71X97	CN71X74	CN71X74	CN71X74	CN71X74
DS1	PILOT LIGHT, NEON	PLX82	PLX82	PLX82	PLX76	PLX76	PLX82	PLX82
F1	FUSE			FZX30				
F2	FUSE			FZX30				
FL1	FILTER, EMI			CAX94				
H1	HEATING ELEMENT	EL480X1A	EL480X1A	EL1205X1	EL480X2A	EL480X1A	EL480X2A	EL480X2A
H2	HEATING ELEMENT	EL480X1A	EL480X1A	EL1205X1	EL480X2A	EL480X1A	EL480X2A	EL480X2A
RY1	RELAY, DPST, N.O.	RYX57	RYX57	RYX57	RYX56	RYX56	RYX57	RYX57
RY2	SOLID STATE RELAY	RYX34	RYX34	RYX34	RYX34	RYX34	RYX34	RYX34
S1	SWITCH	SWX144	SWX144	SWX144	SWX143	SWX143	SWX144	SWX144
S2	DOOR SWITCH	SWX163	SWX163	SWX163	SWX163	SWX163	SWX163	SWX163
S3	DOOR SWITCH	SWX163	SWX163	SWX163	SWX163	SWX163	SWX163	SWX163
TB1	TERMINAL BLOCK	TRX136	TRX136	TRX136	TRX136	TRX136	TRX136	TRX136
TC1	THERMOCOUPLE	TC1165X1	TC1165X1	TC1165X1	TC1165X1	TC1165X1	TC1165X1	TC1165X1

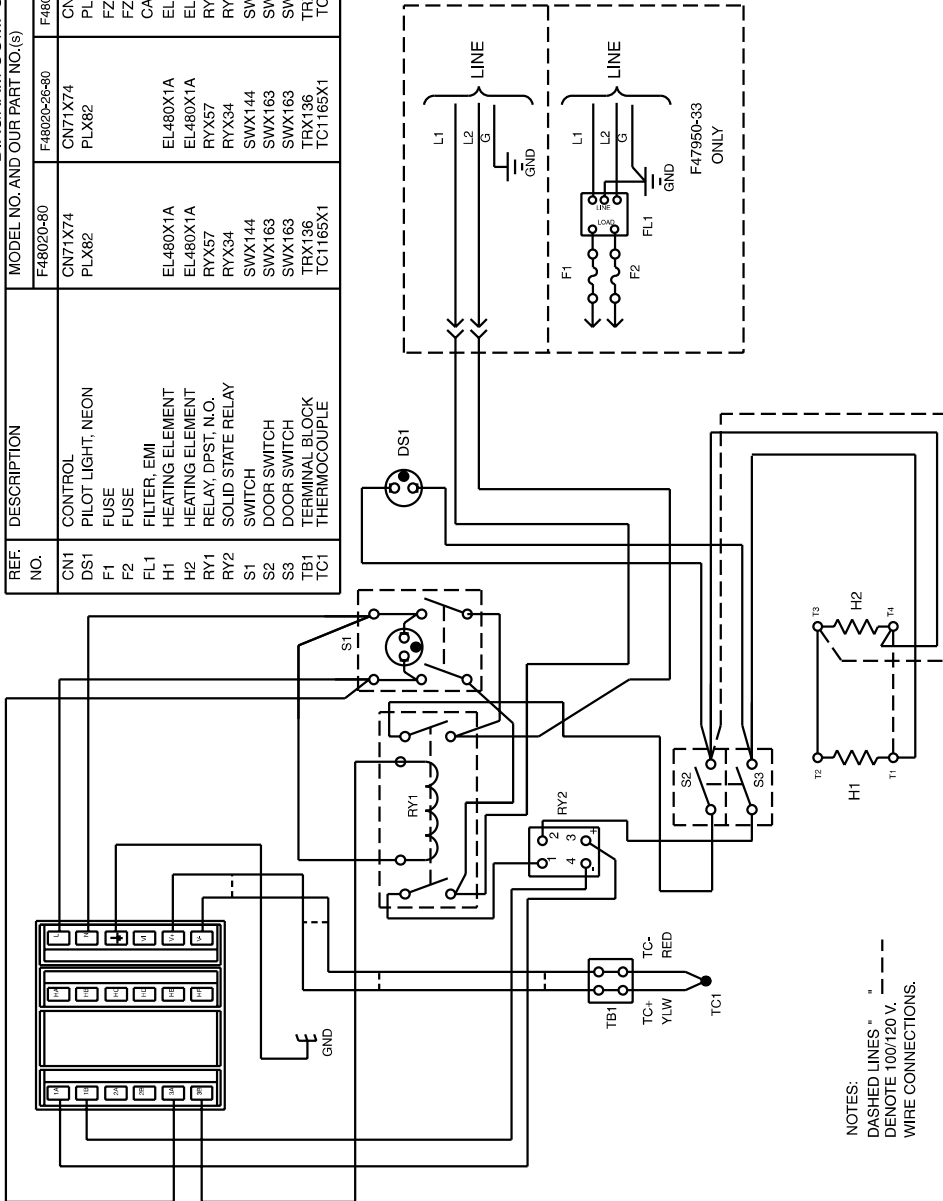

NOTES:
 DASHED LINES *
 DENOTE 100/120 V. ---
 WIRE CONNECTIONS.

WIRING DIAGRAMS

4 x 16 SEGMENT PROGRAMMABLE CONTROL

DIAGRAM COMPONENT LIST

REF. NO.	DESCRIPTION	MODEL NO. AND OUR PART NO.(S)			
		F48050	F48050-26	F48050-33	F48055, F48055-60
CN1	CONTROL	CN71X75 PLX82	CN71X75 PLX82	CN71X98 PLX82	CN71X75 PLX76
DS1	PILOT LIGHT, NEON				
F1	FUSE				
F2	FUSE				
FL1	FILTER, EMI				
H1	HEATING ELEMENT	EL480X1A	EL480X1A	EL480X1A	EL480X1A
H2	HEATING ELEMENT	EL480X1A	EL480X1A	EL480X1A	EL480X2A
RY1	RELAY, DPST, N.O.	RYX57	RYX57	RYX57	RYX57
RY2	SOLID STATE RELAY	RYX34	RYX34	RYX34	RYX34
S1	SWITCH	SWX144	SWX144	SWX144	SWX144
S2	DOOR SWITCH	SWX163	SWX163	SWX163	SWX163
S3	DOOR SWITCH	SWX163	SWX163	SWX163	SWX163
TB1	TERMINAL BLOCK	TRX136	TRX136	TRX136	TRX136
TC1	THERMAL COUPLE	TC1165X1	TC1165X1	TC1165XA	TC1165X1

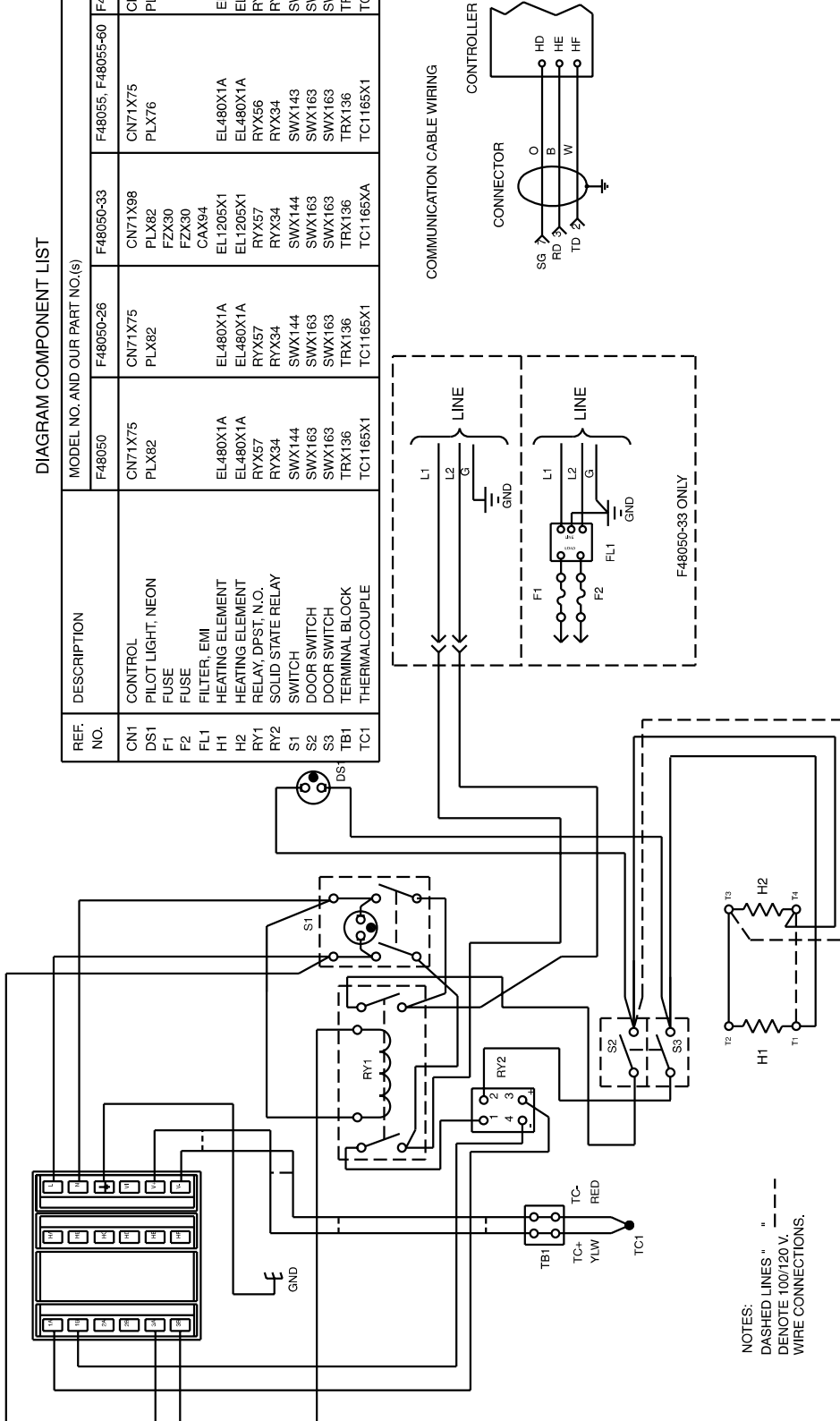

NOTES:
 DASHED LINES " " DENOTE 100/120 V.
 WIRE CONNECTIONS.

Ordering Procedures

Please refer to the Specification Plate for the complete model number, serial number, and series number when requesting service, replacement parts or in any correspondence concerning this unit.

All parts listed herein may be ordered from the **Barnstead International** dealer from whom you purchased this unit or can be obtained promptly from the factory. When service or replacement parts are needed we ask that you check first with your dealer. If the dealer cannot handle your request, then contact our Customer Service Department at 563-556-2241 or 800-553-0039.

Prior to returning any materials to **Barnstead International**, please contact our Customer Service Department for a "Return Goods Authorization" number (RGA). Material Returned without an RGA number will be returned.

One Year Limited Warranty

BARNSTEAD INTERNATIONAL (“BARNSTEAD”) warrants that if a product manufactured by Barnstead shall be free of defects in materials and workmanship for one (1) year from the first to occur of (i) the date the product is sold by BARNSTEAD or (ii) the date the product is purchased by the original retail customer (the “Commencement Date”). Except as expressly stated above, BARNSTEAD MAKES NO OTHER WARRANTY, EXPRESSED OR IMPLIED, WITH RESPECT TO THE PRODUCTS AND EXPRESSLY DISCLAIMS ANY AND ALL WARRANTIES, INCLUDING BUT NOT LIMITED TO, WARRANTIES OF DESIGN, MERCHANT ABILITY AND FITNESS FOR A PARTICULAR PURPOSE.

An authorized representative of BARNSTEAD must perform all warranty inspections. In the event of a defect covered by BARNSTEAD’s warranty, BARNSTEAD shall, as its sole obligation and exclusive remedy, provide free replacement parts to remedy the defective product. In addition, for products sold by BARNSTEAD within the continental United States or Canada, BARNSTEAD shall provide provide free labor to repair the products with the replacement parts, but only for a period of ninety (90) days from the Commencement Date.

BARNSTEAD’s warranty provided hereunder shall be null and void and without further force or effect if there is any (i) repair made to the product by a party other than BARNSTEAD or its duly authorized service representative, (ii) misuse (including use inconsistent with written operating instructions for the product), mishandling, contamination, overheating, modification or alteration of the product by any customer or third party or (iii) use of replacement parts that are obtained from a party who is not an authorized dealer of BARNSTEAD.

Heating elements, because of their susceptibility to overheating and contamination, must be returned to the BARNSTEAD factory and if, upon inspection, it is concluded that failure is due to factors other than excessive high temperature or contamination, BARNSTEAD will provide warranty replacement. As a condition to the return of any product, or any constituent part thereof, to BARNSTEAD’s factory, it shall be sent prepaid and a prior written authorization from BARNSTEAD assigning a Return Goods Number to the product or part shall be obtained.

IN NO EVENT SHALL BARNSTEAD BE LIABLE TO ANY PARTY FOR ANY DIRECT, INDIRECT, SPECIAL, INCIDENTAL, OR CONSEQUENTIAL DAMAGES, OR FOR ANY DAMAGES RESULTING FROM LOSS OF USE OR PROFITS, ANTICIPATED OR OTHERWISE, ARISING OUT OF OR IN CONNECTION WITH THE SALE, USE OR PERFORMANCE OF ANY PRODUCTS, WHETHER SUCH CLAIM IS BASED ON CONTRACT, TORT (INCLUDING NEGLIGENCE), ANY THEORY OF STRICT LIABILITY OR REGULATORY ACTION.

The name of the authorized Barnstead International dealer nearest you may be obtained by calling 1-800-446-6060 (563-556-2241) or writing to:

 **Barnstead International**
an Apogent company *Your Lab Starts Here*

2555 Kerper Boulevard
P.O. Box 797
Dubuque, Iowa 52001-0797
Phone: 563-556-2241 or 800-553-0039
Fax: 563-589-0516
E-mail: mkt@barnstead.com
www.barnstead.com

