

TRAFFIC REPAIR KITS FOR  AMERICAN-DARLING B-62-B AND B-84-B FIRE HYDRANTS

SPECIFICATIONS

ITEM NUMBER	DESCRIPTION	MATERIAL	QTY.
1A	Breakable Bolt & Nut	Zinc-Plated Steel	8 *
1B	Bolt & Nut	Zinc-Plated Steel	8 *
2	Breakable Stem Coupling	Cast Iron	1
3	Clevis Pin	Stainless Steel	2
4	Cotter Pin	Stainless Steel	2
5	Flange Gasket	Neoprene	1
6	Snap Ring	Stainless Steel	1
7	Breakable Safety Flange	Cast Iron	1

*Note: When ordering, state hydrant year to determine the correct bolts. Kits for B-62-B's, made before 1986, only require items numbered: 1A, 2, 3, 4, and 5.

SIZE: 5 1/4" or 6" Main Valve Opening

HRPI Products are engineered and manufactured using the latest computerized technology to ensure quality products with repeatable tolerances.

HRPI Guarantees this product to be compatible, and will operate with the fire hydrant when installed properly. The use of this product shall not affect any published warranties available to the buyer.

PRODUCTS MEET OR EXCEED THE AWWA C502 STANDARD FOR DRY-BARREL FIRE HYDRANTS.

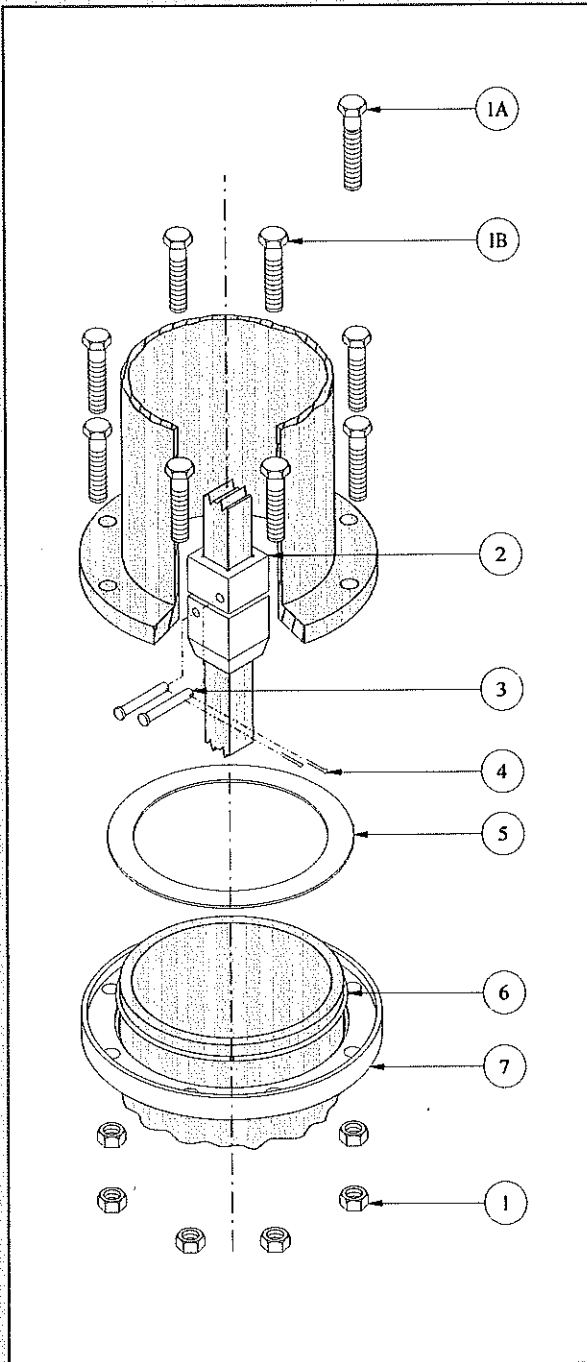

FAX: (918) 224-6857

Hydrant Repair Parts, Inc.

7900 New Sapulpa Road, Tulsa, OK 74131 • (918) 224-8713

1-800-776-8713 or 1-800-548-9123

American-Darling is a registered trademark of American Flow Control, a division of American Cast Iron Pipe Co., Birmingham, AL.
Hydrant Repair Parts, Inc. is not affiliated with American Flow Control.