

EXTENSION KITS FOR  U.S. PIPE M-94
FIRE HYDRANTS

SPECIFICATIONS

ITEM NUMBER	DESCRIPTION	MATERIAL	QTY.
1	Standpipe Extension	Ductile Pipe	1
2	Extension Stem	Steel	1
3	Extension Stem Coupling	Cast Iron	1
4	Extension Standpipe Coupling (HALF CIRCLE)	Ductile	2
5	Standpipe Coupling Bolt & Nut	Stainless Steel	2
6	Clevis Pin	Stainless Steel	2
7	Cotter Pin	Stainless Steel	2
8	Standpipe Coupling Seal	Lathe-Cut Buna-N Rubber	1
9	Stem Dampener "O"-Ring (Not Shown)	Buna-N Rubber	1

SIZE: 4½" or 5¼" Main Valve Opening

HRPI Products are engineered and manufactured using the latest computerized technology to ensure quality products with repeatable tolerances.

HRPI Guarantees this product to be compatible, and will operate with the fire hydrant when installed properly. The use of this product shall not affect any published warranties available to the buyer.

PRODUCTS MEET OR EXCEED THE AWWA C502 STANDARD FOR DRY-BARREL FIRE HYDRANTS.

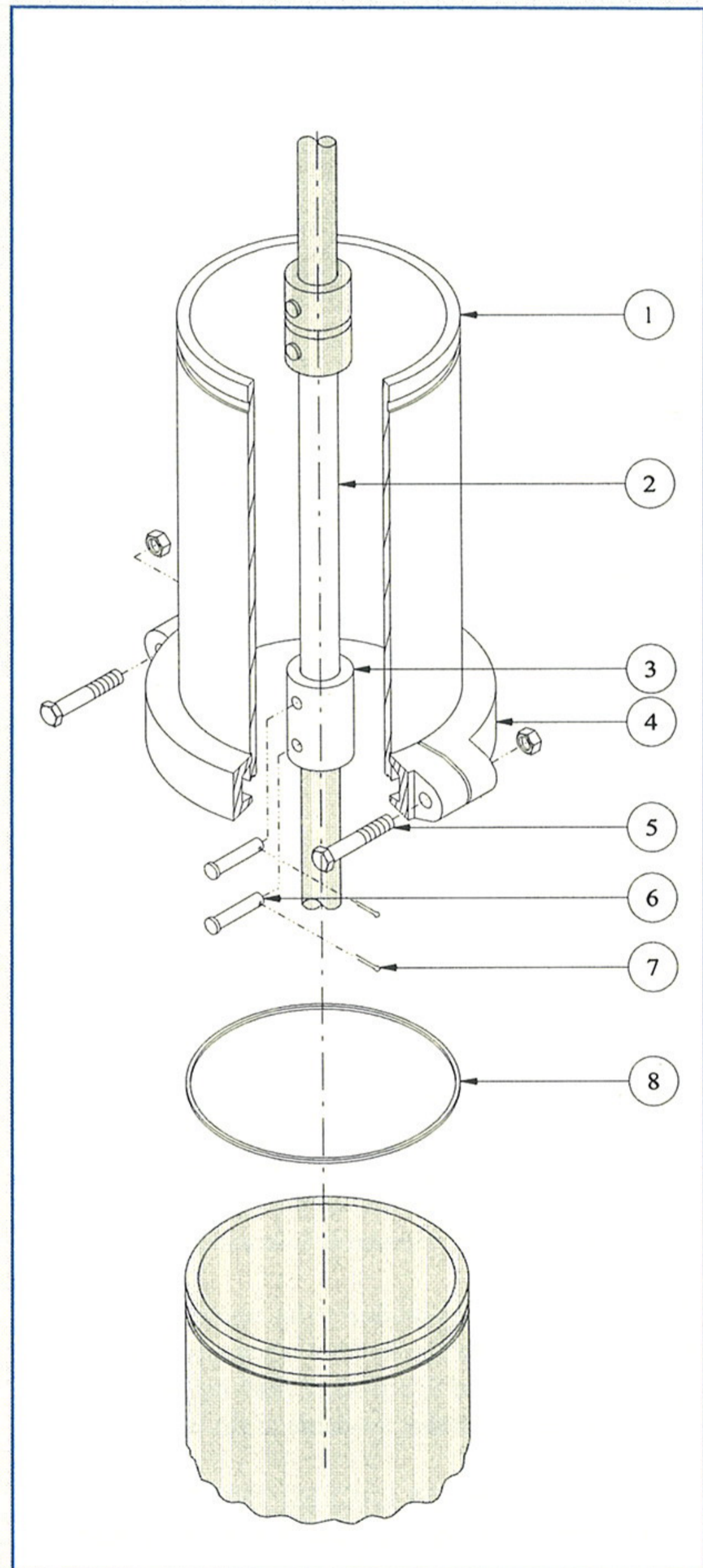

FAX: (918) 224-6857

Hydrant Repair Parts, Inc.

7900 New Sapulpa Road, Tulsa, OK 74131 • (918) 224-8713

1-800-776-8713 or 1-800-548-9123

U.S. Pipe is a registered trademark of U.S. Pipe & Foundry Co., Birmingham, AL.
Hydrant Repair Parts, Inc., is not affiliated with U.S. Pipe & Foundry Co.