

PART #	OLD PART #	CATEGORY	TYPE	DESCRIPTION	QTY	COMMENT
1	UCBR-00003294	Component Part	Bracket	BRACKET T-13H W/ 3/8" ANCHORS	1	
2	USLB-00000922	Shipping-Packaging Part	Label	1 1/2" x 7/8", Fabrication Sticker	1	Apply After Paint
3	USLB-00003933	Shipping-Packaging Part	Label	4" x 5", Box Label	Determined by Order Size	1 Label per Box
4	USBX-00000971	Shipping-Packaging Part	Box	Re-User	Determined by Order Size	
5	USPL-00001452	Shipping-Packaging Part	Pallet	Re-User	Determined by Order Size	

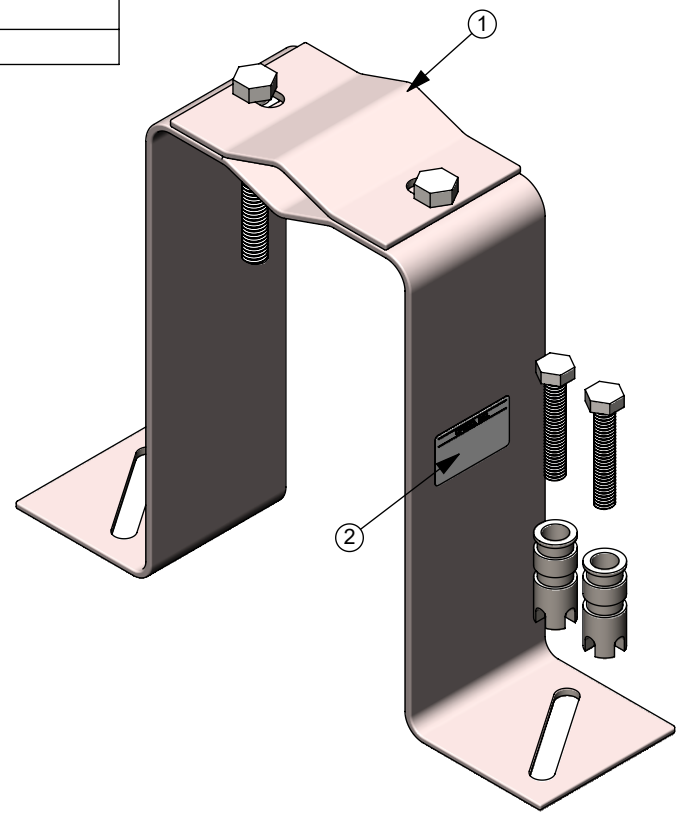
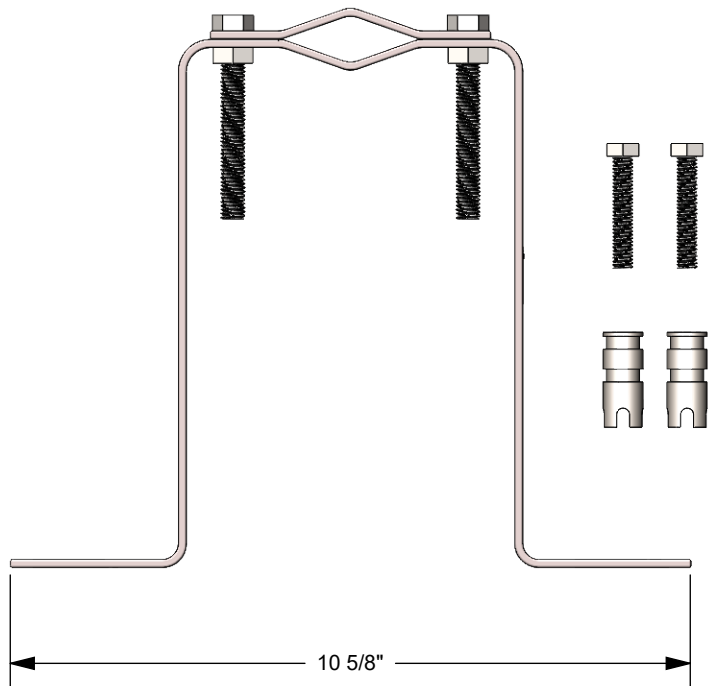
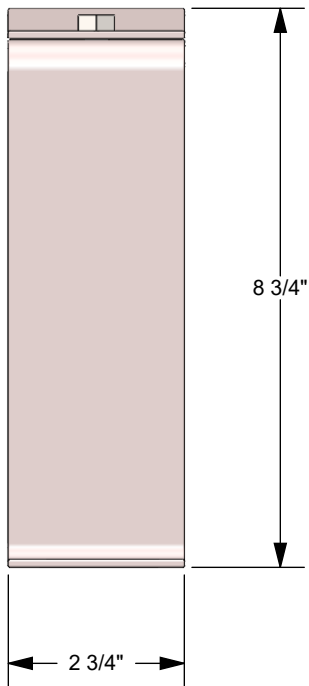

Rev	Change Description	Date
P02	Revise to current Upsco drawing standard.	6/18/2019

**UPSCO INC**  
 PO Box 431 - 67 Central St  
 Moravia, NY 13118  
 P: 315.497.1070  
 F: 315.497.0223  
 www.UPSCOINC.COM

UPSCO #: UABK-00002198 (U42802)  
 Description: U9, A38  
 Drawing Type: Production  
 Product Type: Assembly - Bracket Kit  
 Drawing Date: 8/2/2016  
 Drawing Rev: P02

Customer: Utility Products Specialists Co., Inc. (UPSCO)  
 Pipe Dope: N/A  
 Test Pressure: 0 - @ 0 -  
 Manometer: N/A  
 Page Number: 1 of 1  
 Primer: N/A  
 Paint: N/A  
 Packaging: 0 per - / 0 - per  
 Drawing Author: Jason Halton

**TOLERANCES**  
 FRACTIONS ±1/8"      ANGLES ±1°  
 \*BREAK AND DEBURR ALL SHARP EDGES\*