

TRAFFIC REPAIR KITS FOR  MUELLER IMPROVED OLD STYLE (PRIOR TO 1972) FIRE HYDRANTS

## SPECIFICATIONS

ITEM NUMBER	DESCRIPTION	MATERIAL	QTY.
1	Bolt & Nut	Zinc-Plated Steel	8
2	Hydrant Lubricant	FDA Approved Mineral Oil	1
3	Safety Stem Coupling	Brass	1
4	Set Screw	Stainless Steel	1
5	Flange Gasket	Cloth-Inserted SBR Rubber	1
6	Breakable Safety Flange (SET)	Cast Iron	1

SIZE: 4¼", 4½", or 5¼" Main Valve Opening

HRPI Products are engineered and manufactured using the latest computerized technology to ensure quality products with repeatable tolerances.

HRPI Guarantees this product to be compatible, and will operate with the fire hydrant when installed properly. The use of this product shall not affect any published warranties available to the buyer.

PRODUCTS MEET OR EXCEED THE AWWA C502 STANDARD FOR DRY-BARREL FIRE HYDRANTS.

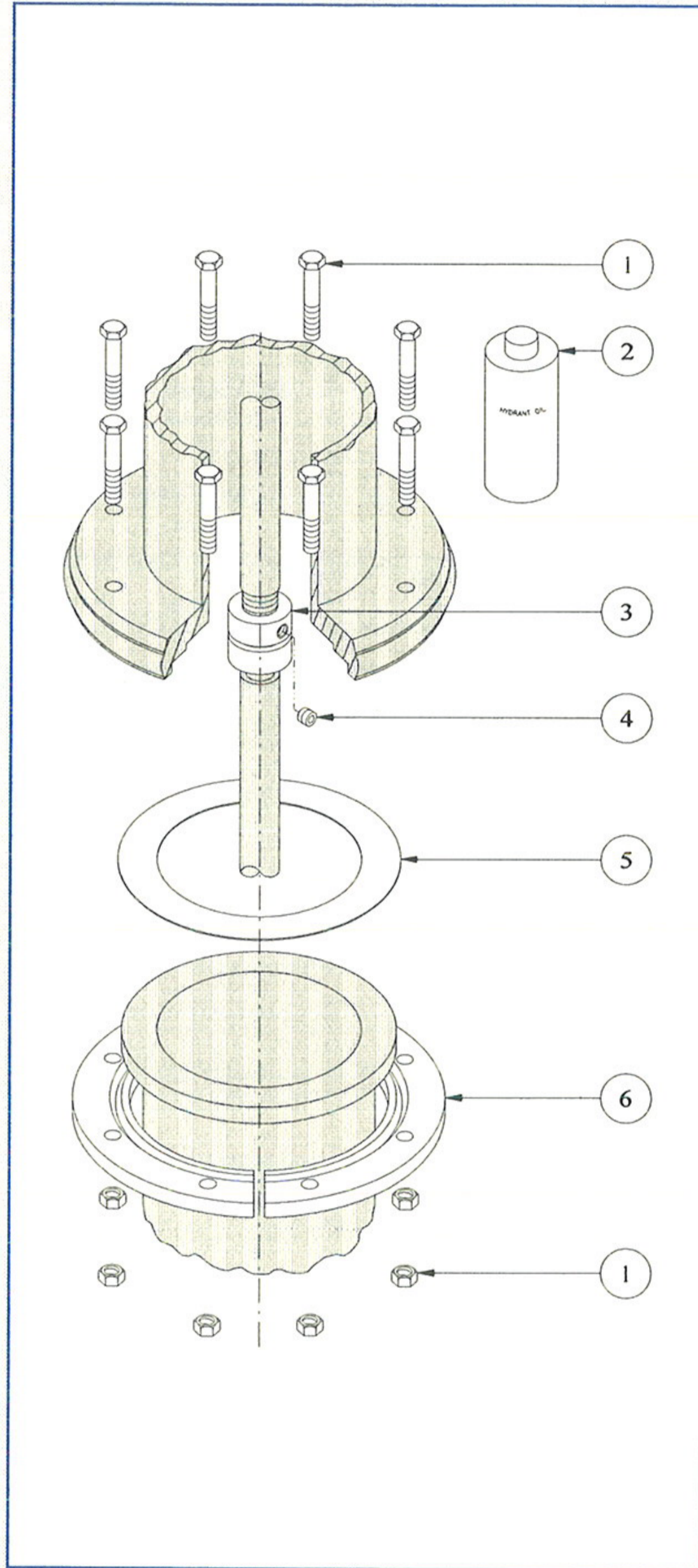

FAX: (918) 224-6857

# Hydrant Repair Parts, Inc.

7900 New Sapulpa Road, Tulsa, OK 74131 • (918) 224-8713

1-800-776-8713 or 1-800-548-9123

Mueller is a registered trademark of Mueller Co., Decatur, Illinois.  
Hydrant Repair Parts, Inc., is not affiliated with Mueller Co.