

*Specification Sheets  
For  
Extensions and Traffic Repair Kits*



***Hydrant Repair Parts, Inc.***

7900 New Sapulpa Road, Tulsa, OK 74131 • (918) 224-8713

1-800-776-8713 or 1-800-548-9123

**FAX: (918) 224-6857**



EXTENSION KITS FOR  MUELLER SUPER-200, CENTURION, AND IMPROVED NEW STYLE FIRE HYDRANTS

## SPECIFICATIONS

ITEM NUMBER	DESCRIPTION	MATERIAL	QTY.
1	Flange Gasket	Cloth-Inserted SBR Rubber	2
2	Extension Barrel	Ductile Iron	1
3	Extension Stem	Steel	1
4	Hydrant Lubricant	FDA Approved Mineral Oil	1
5	Bolt & Nut	Zinc-Plated Steel	8
6	Extension Stem Coupling	Stainless Steel	1
7	Cotter & Clevis Pin	Stainless Steel	2
8	Extension Flange (SET)	Ductile Iron	1
9	Bonnet Gasket (Not Shown)	Cloth-Inserted SBR Rubber	1

SIZE: 4½" or 5¼" Main Valve Opening

HRPI Products are engineered and manufactured using the latest computerized technology to ensure quality products with repeatable tolerances.

HRPI Guarantees this product to be compatible, and will operate with the fire hydrant when installed properly. The use of this product shall not affect any published warranties available to the buyer.

PRODUCTS MEET OR EXCEED THE AWWA C502 STANDARD FOR DRY-BARREL FIRE HYDRANTS.

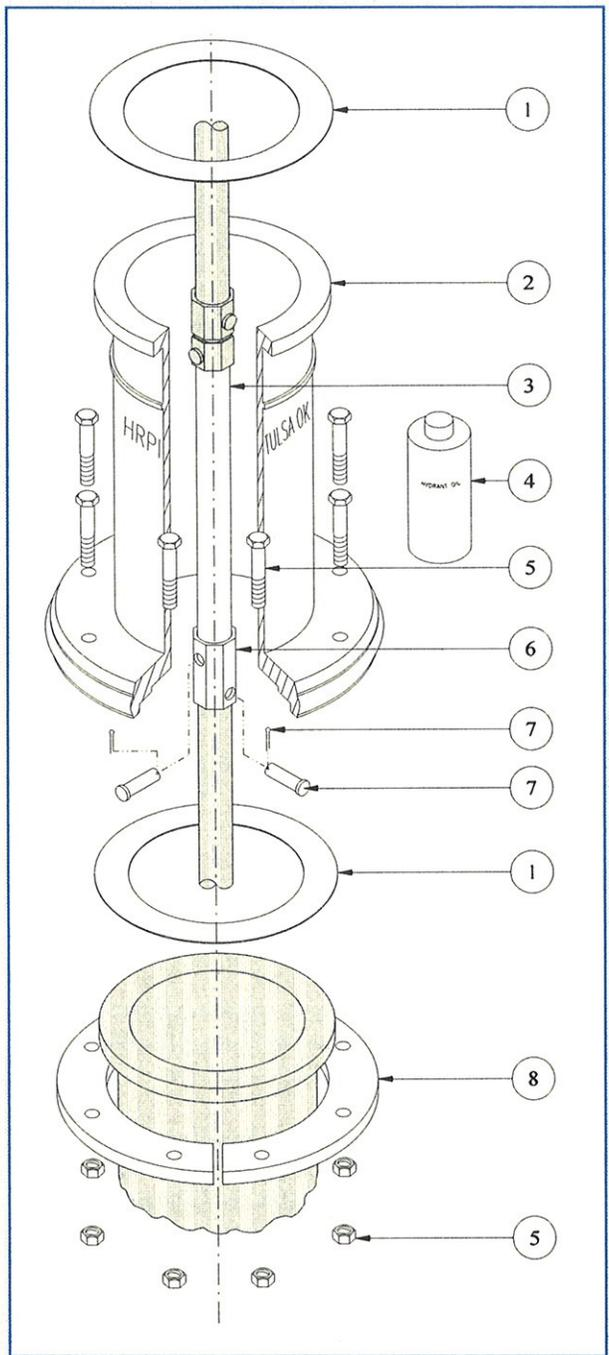

FAX: (918) 224-6857

# Hydrant Repair Parts, Inc.

7900 New Sapulpa Road, Tulsa, OK 74131 • (918) 224-8713

1-800-776-8713 or 1-800-548-9123

TRAFFIC REPAIR  MUELLER SUPER-200, CENTURION,  
KITS FOR AND IMPROVED NEW STYLE FIRE HYDRANTS

## SPECIFICATIONS

ITEM NUMBER	DESCRIPTION	MATERIAL	QTY.
1	Bolt & Nut	Zinc-Plated Steel	8
2	Hydrant Lubricant	FDA Approved Mineral Oil	1
3	Safety Stem Coupling	Stainless Steel	1
4	Cotter Pin	Stainless Steel	2
5	Clevis Pin	Stainless Steel	2
6	Flange Gasket	Cloth-Inserted SBR Rubber	1
7	Breakable Safety Flange (SET)	Cast Iron	1
8	Bonnet Gasket (Not Shown)	Cloth-Inserted SBR Rubber	1

SIZE: 4½" or 5¼" Main Valve Opening

HRPI Products are engineered and manufactured using the latest computerized technology to ensure quality products with repeatable tolerances.

HRPI Guarantees this product to be compatible, and will operate with the fire hydrant when installed properly. The use of this product shall not affect any published warranties available to the buyer.

PRODUCTS MEET OR EXCEED THE AWWA C502 STANDARD FOR DRY-BARREL FIRE HYDRANTS.

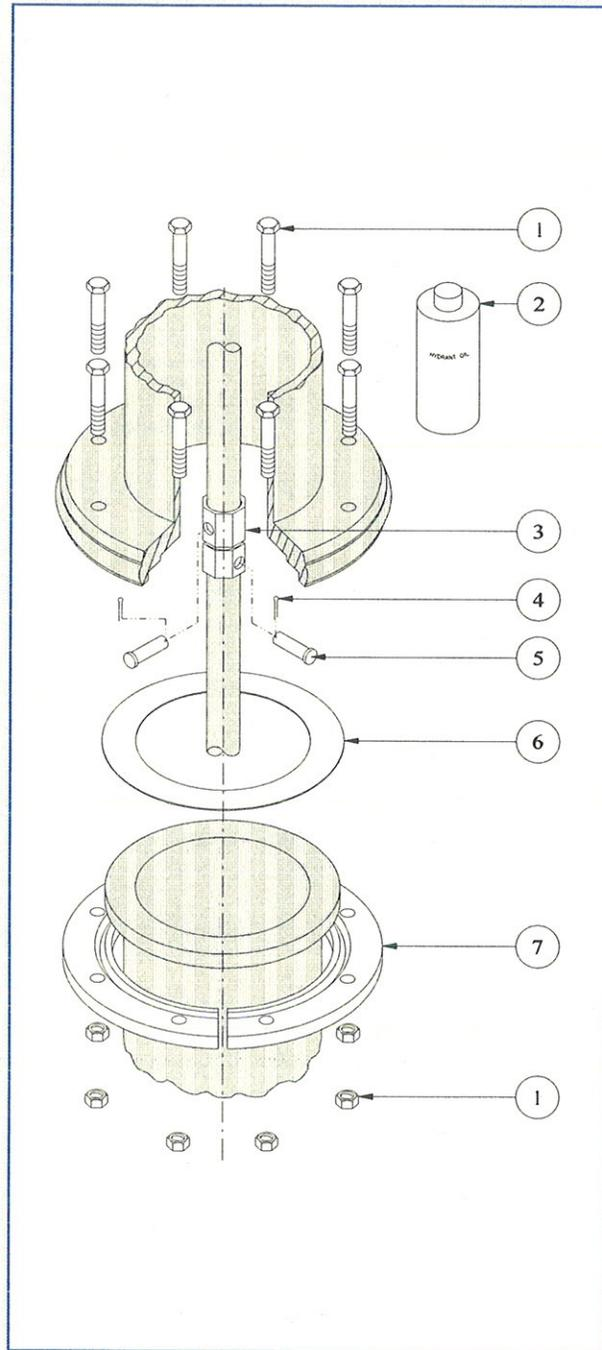

FAX: (918) 224-6857

# Hydrant Repair Parts, Inc.

7900 New Sapulpa Road, Tulsa, OK 74131 • (918) 224-8713

1-800-776-8713 or 1-800-548-9123

Mueller is a registered trademark of Mueller Co., Decatur, Illinois.  
Hydrant Repair Parts, Inc. is not affiliated with Mueller Co.

EXTENSION KITS  
FOR



MUELLER IMPROVED  
OLD STYLE (PRIOR TO 1972) FIRE HYDRANTS

## SPECIFICATIONS

ITEM NUMBER	DESCRIPTION	MATERIAL	QTY.
1	Flange Gasket	Cloth-Inserted SBR Rubber	2
2	Extension Barrel	Ductile Iron	1
3	Threaded Extension Stem	Steel	1
4	Hydrant Lubricant	FDA Approved Mineral Oil	1
5	Bolt & Nut	Zinc-Plated Steel	8
6	Extension Stem Coupling	Brass	1
7	Set Screw	Stainless Steel	1
8	Extension Flange (SET)	Ductile Iron	1

SIZE: 4¼", 4½", or 5¼" Main Valve Opening

HRPI Products are engineered and manufactured using the latest computerized technology to ensure quality products with repeatable tolerances.

HRPI Guarantees this product to be compatible, and will operate with the fire hydrant when installed properly. The use of this product shall not affect any published warranties available to the buyer.

PRODUCTS MEET OR EXCEED THE AWWA C502 STANDARD FOR DRY-BARREL FIRE HYDRANTS.

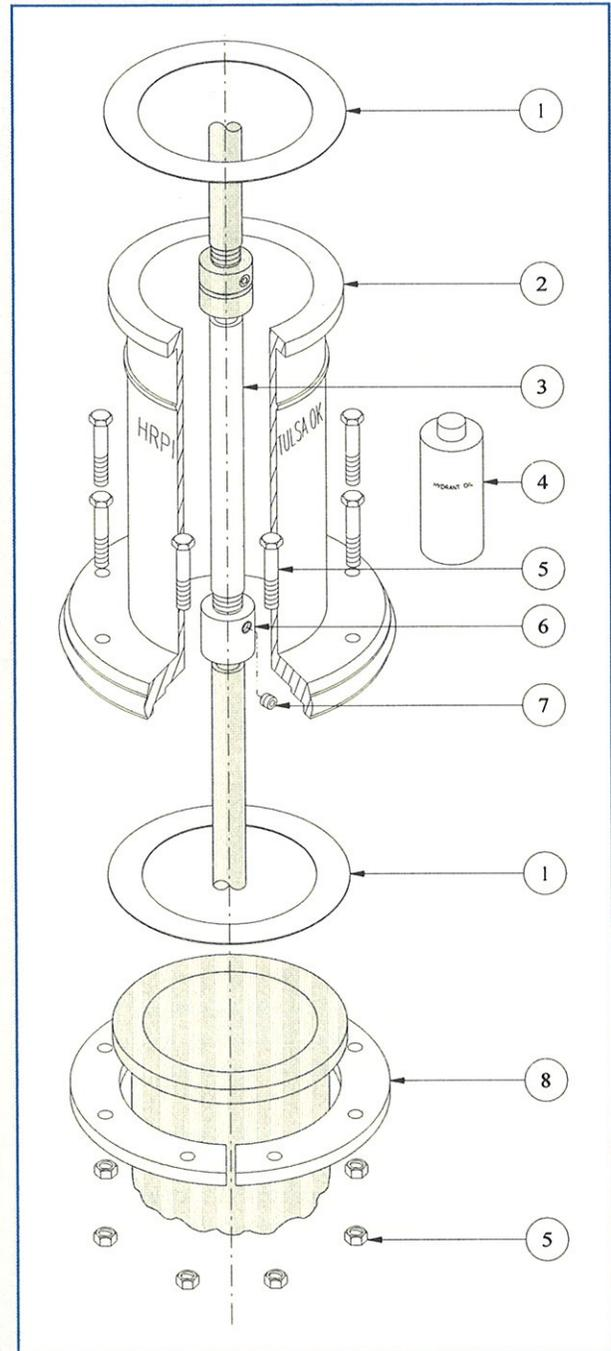

FAX: (918) 224-6857

# Hydrant Repair Parts, Inc.

7900 New Sapulpa Road, Tulsa, OK 74131 • (918) 224-8713

1-800-776-8713 or 1-800-548-9123

Mueller is a registered trademark of Mueller Co., Decatur, Illinois.  
Hydrant Repair Parts, Inc., is not affiliated with Mueller Co.

TRAFFIC REPAIR KITS FOR  MUELLER IMPROVED OLD STYLE (PRIOR TO 1972) FIRE HYDRANTS

## SPECIFICATIONS

ITEM NUMBER	DESCRIPTION	MATERIAL	QTY.
1	Bolt & Nut	Zinc-Plated Steel	8
2	Hydrant Lubricant	FDA Approved Mineral Oil	1
3	Safety Stem Coupling	Brass	1
4	Set Screw	Stainless Steel	1
5	Flange Gasket	Cloth-Inserted SBR Rubber	1
6	Breakable Safety Flange (SET)	Cast Iron	1

SIZE: 4¼", 4½", or 5¼" Main Valve Opening

HRPI Products are engineered and manufactured using the latest computerized technology to ensure quality products with repeatable tolerances.

HRPI Guarantees this product to be compatible, and will operate with the fire hydrant when installed properly. The use of this product shall not affect any published warranties available to the buyer.

PRODUCTS MEET OR EXCEED THE AWWA C502 STANDARD FOR DRY-BARREL FIRE HYDRANTS.

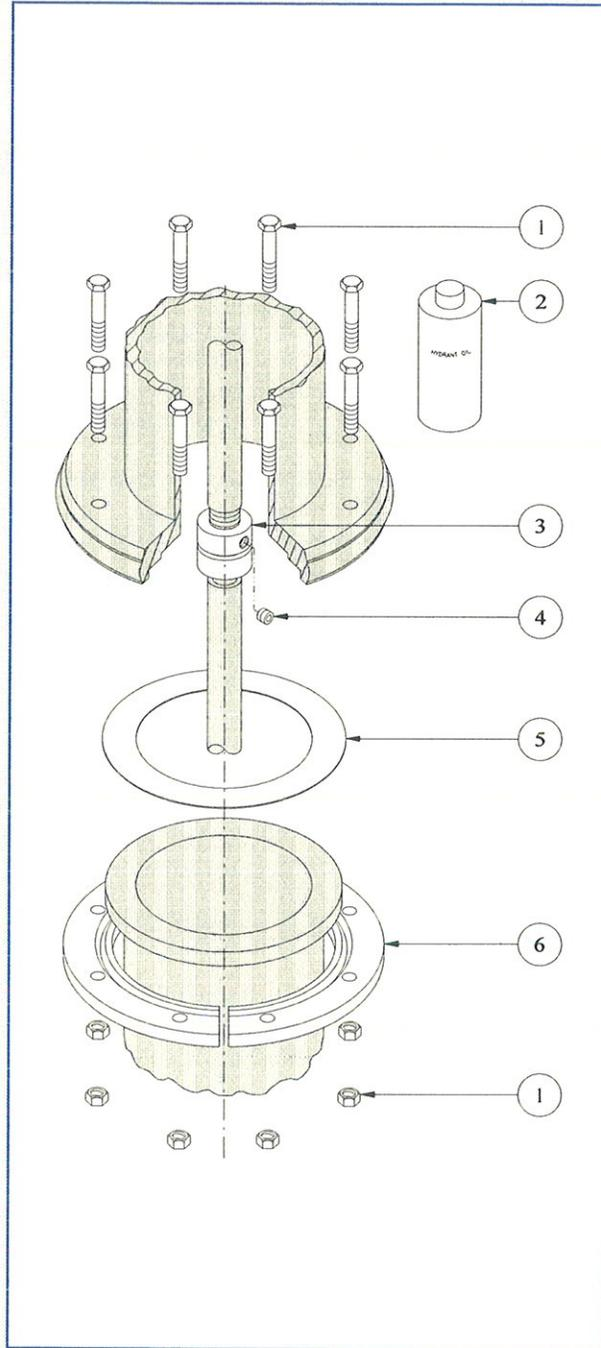

FAX: (918) 224-6857

# Hydrant Repair Parts, Inc.

7900 New Sapulpa Road, Tulsa, OK 74131 • (918) 224-8713

1-800-776-8713 or 1-800-548-9123

Mueller is a registered trademark of Mueller Co., Decatur, Illinois.  
Hydrant Repair Parts, Inc., is not affiliated with Mueller Co.

EXTENSION KITS FOR  MUELLER SUPER-250 FIRE HYDRANTS

## SPECIFICATIONS

ITEM NUMBER	DESCRIPTION	MATERIAL	QTY.
1	Upper Flange "O"-Ring	Buna-N Rubber	1
2	Extension Barrel	Ductile Iron	1
3	Extension Stem	Steel	1
4	Hydrant Lubricant	FDA Approved Mineral Oil	1
5	Bolt & Nut	Zinc-Plated Steel	8
6	Extension Stem Coupling	Stainless Steel	1
7	Cotter Pin	Stainless Steel	2
8	Clevis Pin	Stainless Steel	2
9	Flange Gasket	Cloth-Inserted SBR Rubber	2
10	Extension Flange (SET)	Ductile Iron	1
11	Bonnet "O"-Ring (Not Shown)	Buna-N Rubber	1

SIZE: 4½" or 5¼" Main Valve Opening

HRPI Products are engineered and manufactured using the latest computerized technology to ensure quality products with repeatable tolerances.

HRPI Guarantees this product to be compatible, and will operate with the fire hydrant when installed properly. The use of this product shall not affect any published warranties available to the buyer.

PRODUCTS MEET OR EXCEED THE AWWA C502 STANDARD FOR DRY-BARREL FIRE HYDRANTS.

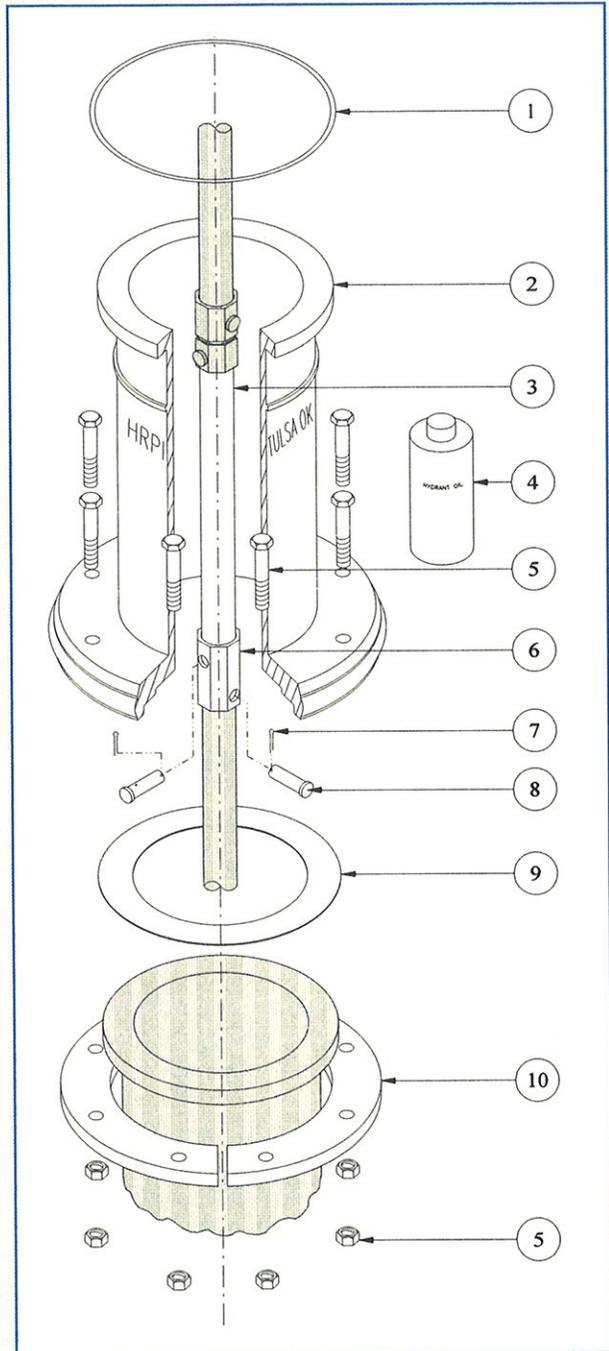

FAX: (918) 224-6857

# Hydrant Repair Parts, Inc.

7900 New Sapulpa Road, Tulsa, OK 74131 • (918) 224-8713

1-800-776-8713 or 1-800-548-9123

## SPECIFICATIONS

ITEM NUMBER	DESCRIPTION	MATERIAL	QTY.
1	Bolt & Nut	Zinc-Plated Steel	8
2	Hydrant Lubricant	FDA Approved Mineral Oil	1
3	Safety Stem Coupling	Stainless Steel	1
4	Cotter Pin	Stainless Steel	2
5	Clevis Pin	Stainless Steel	2
6	Upper Flange "O"-Ring	Buna-N Rubber	1
7	Breakable Safety Flange (SET)	Cast Iron	1
8	Bonnet "O"-Ring (Not Shown)	Buna-N Rubber	1

SIZE: 4½" or 5¼" Main Valve Opening

HRPI Products are engineered and manufactured using the latest computerized technology to ensure quality products with repeatable tolerances.

HRPI Guarantees this product to be compatible, and will operate with the fire hydrant when installed properly. The use of this product shall not affect any published warranties available to the buyer.

PRODUCTS MEET OR EXCEED THE AWWA C502 STANDARD FOR DRY-BARREL FIRE HYDRANTS.

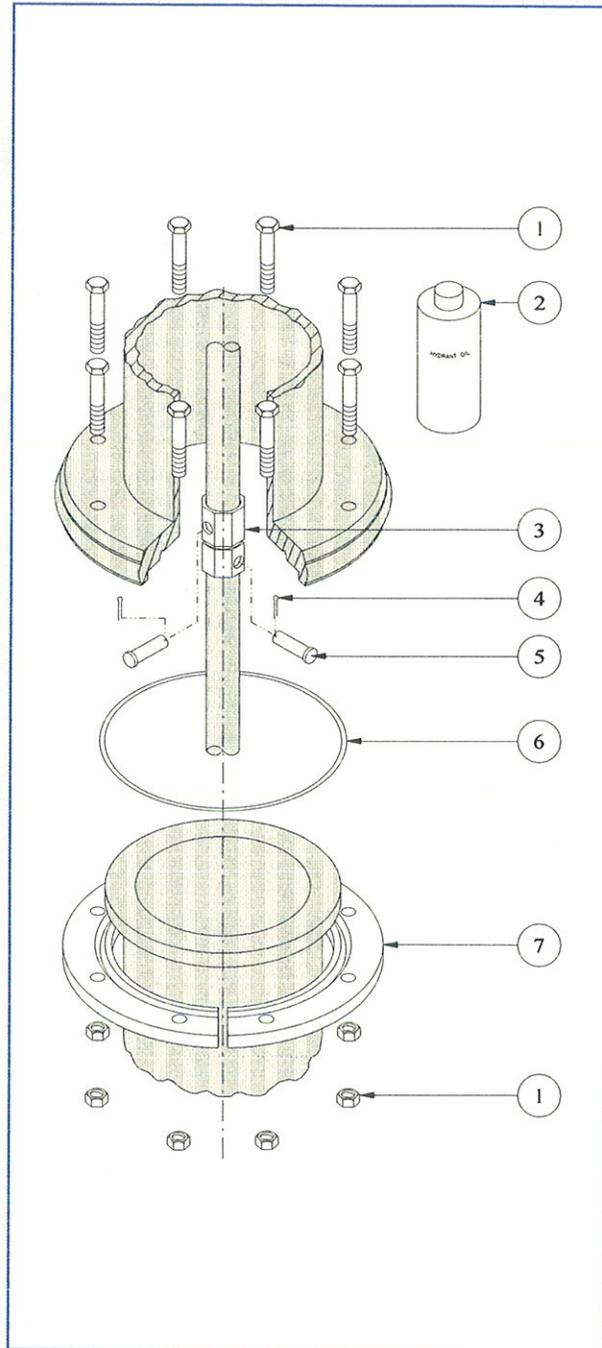

FAX: (918) 224-6857

# Hydrant Repair Parts, Inc.

7900 New Sapulpa Road, Tulsa, OK 74131 • (918) 224-8713

1-800-776-8713 or 1-800-548-9123

Mueller is a registered trademark of Mueller Co., Decatur, Illinois.  
Hydrant Repair Parts, Inc. is not affiliated with Mueller Co.

EXTENSION KITS FOR  CLOW MEDALLION  
FIRE HYDRANTS

## SPECIFICATIONS

ITEM NUMBER	DESCRIPTION	MATERIAL	QTY.
1	Upper Flange "O"-Ring	Buna-N Rubber	1
2	Extension Barrel	Ductile Iron	1
3	Extension Stem	Steel	1
4	Hydrant Lubricant	FDA Approved Mineral Oil	1
5	Bolt & Nut	Zinc-Plated Steel	8
6	Extension Stem Coupling	Stainless Steel	1
7	Cotter Pin	Stainless Steel	2
8	Clevis Pin	Stainless Steel	2
9	Lower Flange "O"-Ring	Buna-N Rubber	1
10	Extension Flange (SET)	Ductile Iron	1

SIZE: 4½" or 5¼" Main Valve Opening

HRPI Products are engineered and manufactured using the latest computerized technology to ensure quality products with repeatable tolerances.

HRPI Guarantees this product to be compatible, and will operate with the fire hydrant when installed properly. The use of this product shall not affect any published warranties available to the buyer.

PRODUCTS MEET OR EXCEED THE AWWA C502 STANDARD FOR DRY-BARREL FIRE HYDRANTS.

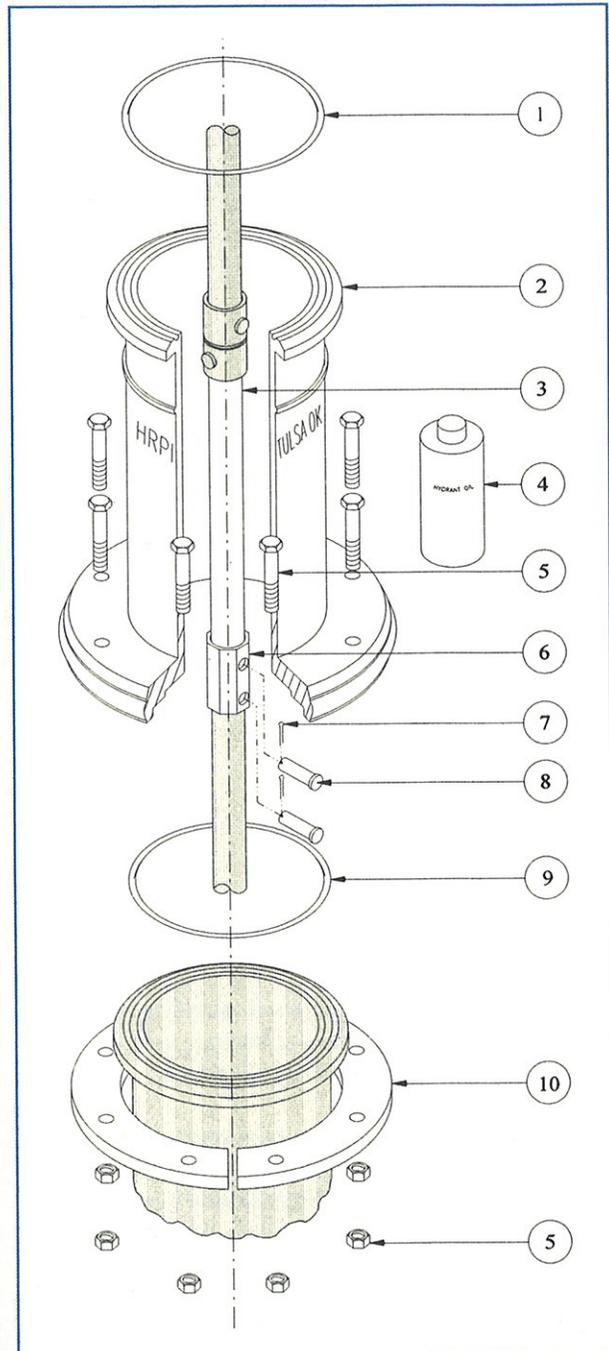

FAX: (918) 224-6857

# Hydrant Repair Parts, Inc.

7900 New Sapulpa Road, Tulsa, OK 74131 • (918) 224-8713

1-800-776-8713 or 1-800-548-9123

## SPECIFICATIONS

ITEM NUMBER	DESCRIPTION	MATERIAL	QTY.
1	Bolt & Nut	Zinc-Plated Steel	8
2	Hydrant Lubricant	FDA Approved Mineral Oil	1
3	Safety Stem Coupling	Steel	1
4	Cotter Pin	Stainless Steel	2
5	Clevis Pin	Stainless Steel	2
6	Upper Flange "O"-Ring	Buna-N Rubber	1
7	Breakable Safety Flange (SET)	Cast Iron	1

SIZE: 4½" or 5¼" Main Valve Opening

HRPI Products are engineered and manufactured using the latest computerized technology to ensure quality products with repeatable tolerances.

HRPI Guarantees this product to be compatible, and will operate with the fire hydrant when installed properly. The use of this product shall not affect any published warranties available to the buyer.

PRODUCTS MEET OR EXCEED THE AWWA C502 STANDARD FOR DRY-BARREL FIRE HYDRANTS.

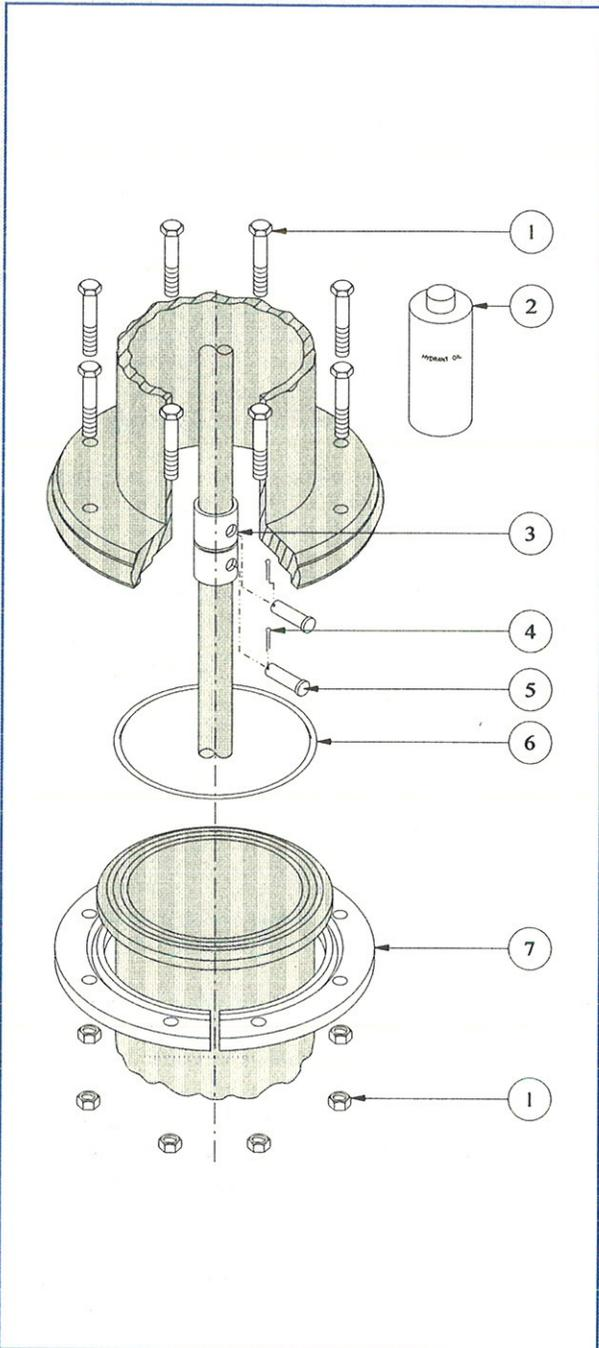

FAX: (918) 224-6857

# Hydrant Repair Parts, Inc.

7900 New Sapulpa Road, Tulsa, OK 74131 • (918) 224-8713

1-800-776-8713 or 1-800-548-9123

Clow is a registered trademark of Clow Valve Co., a division of McWane, Inc., Okaloosa, Iowa.  
Hydrant Repair Parts, Inc., is not affiliated with Clow Valve Co.

EXTENSION KITS FOR  CLOW 2500 FIRE HYDRANTS

## SPECIFICATIONS

ITEM NUMBER	DESCRIPTION	MATERIAL	QTY.
1	Upper Standpipe Gasket	Neoprene	1
2	Standpipe Extension	Ductile Pipe	1
3	Extension Stem	Steel	1
4	Bolt & Nut	Zinc-Plated Steel	8
5	Unbreakable Standpipe Flange	Ductile Iron	2
6	Extension Stem Coupling	Cast Iron	1
7	Snap Ring	Stainless Steel	2
8	Coupling Bolt & Nut	Stainless Steel	2
9	Lower Standpipe Gasket	Molded "T" Neoprene	1

SIZE: 4½" or 5¼" Main Valve Opening

HRPI Products are engineered and manufactured using the latest computerized technology to ensure quality products with repeatable tolerances.

HRPI Guarantees this product to be compatible, and will operate with the fire hydrant when installed properly. The use of this product shall not affect any published warranties available to the buyer.

PRODUCTS MEET OR EXCEED THE AWWA C502 STANDARD FOR DRY-BARREL FIRE HYDRANTS.

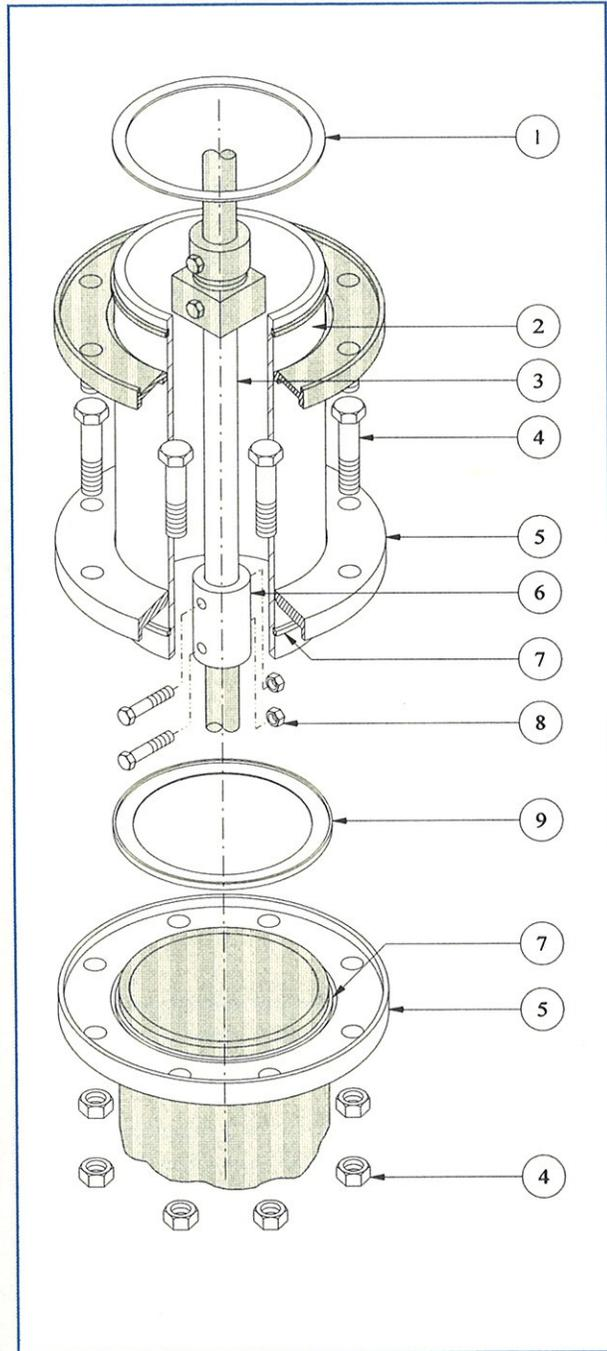

FAX: (918) 224-6857

# Hydrant Repair Parts, Inc.

7900 New Sapulpa Road, Tulsa, OK 74131 • (918) 224-8713

1-800-776-8713 or 1-800-548-9123

## SPECIFICATIONS

ITEM NUMBER	DESCRIPTION	MATERIAL	QTY.
1	Bolt & Nut	Zinc-Plated Steel	8
2	Safety Stem Coupling	Cast Iron	1
3	Coupling Bolt & Nut	Stainless Steel	2
4	Upper Standpipe Gasket	Neoprene	1
5	Snap Ring	Stainless Steel	1
6	Safety Flange	Cast Iron	1

SIZE: 4½" or 5¼" Main Valve Opening

HRPI Products are engineered and manufactured using the latest computerized technology to ensure quality products with repeatable tolerances.

HRPI Guarantees this product to be compatible, and will operate with the fire hydrant when installed properly. The use of this product shall not affect any published warranties available to the buyer.

PRODUCTS MEET OR EXCEED THE AWWA C502 STANDARD FOR DRY-BARREL FIRE HYDRANTS.

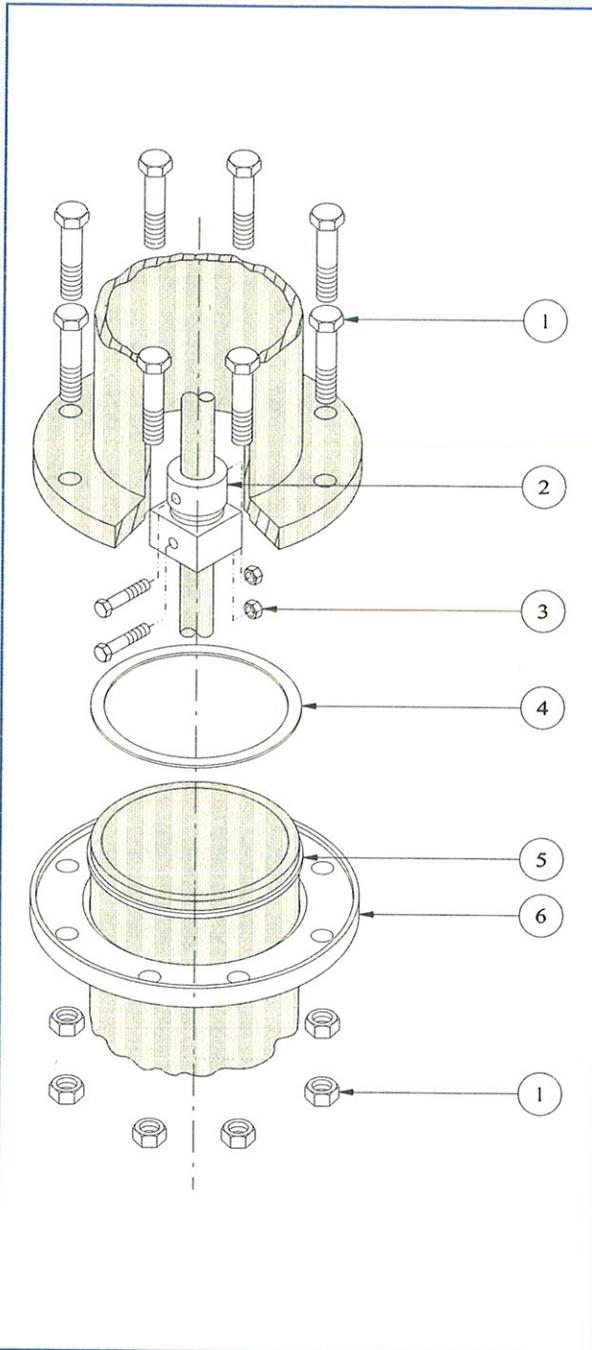

FAX: (918) 224-6857

# Hydrant Repair Parts, Inc.

7900 New Sapulpa Road, Tulsa, OK 74131 • (918) 224-8713

1-800-776-8713 or 1-800-548-9123

Clow is a registered trademark of Clow Valve Co., a division of McWane, Inc., Okaloosa, Iowa.  
Hydrant Repair Parts, Inc., is not affiliated with Clow Valve Co.

EXTENSION KITS FOR  CLOW EDDY FIRE HYDRANTS

## SPECIFICATIONS

ITEM NUMBER	DESCRIPTION	MATERIAL	QTY.
1	Flange Gasket	Cloth-Inserted SBR Rubber	2
2	Drain Rod Extension	Zinc-Plated Steel	1
3	Extension Barrel	Cast Iron or Ductile	1
4	Extension Stem	Steel	1
5	Bolt & Nut	Zinc-Plated Steel	8
6	Jam Nut	Brass	2
7	Drain Rod Connector	Zinc-Plated Steel	1
8	Extension Stem Coupling	Cast Iron	1
9	Coupling Bolt & Nut	Stainless Steel	2

SIZE: 4¼", 4½", or 5¼" Main Valve Opening

HRPI Products are engineered and manufactured using the latest computerized technology to ensure quality products with repeatable tolerances.

HRPI Guarantees this product to be compatible, and will operate with the fire hydrant when installed properly. The use of this product shall not affect any published warranties available to the buyer.

PRODUCTS MEET OR EXCEED THE AWWA C502 STANDARD FOR DRY-BARREL FIRE HYDRANTS.

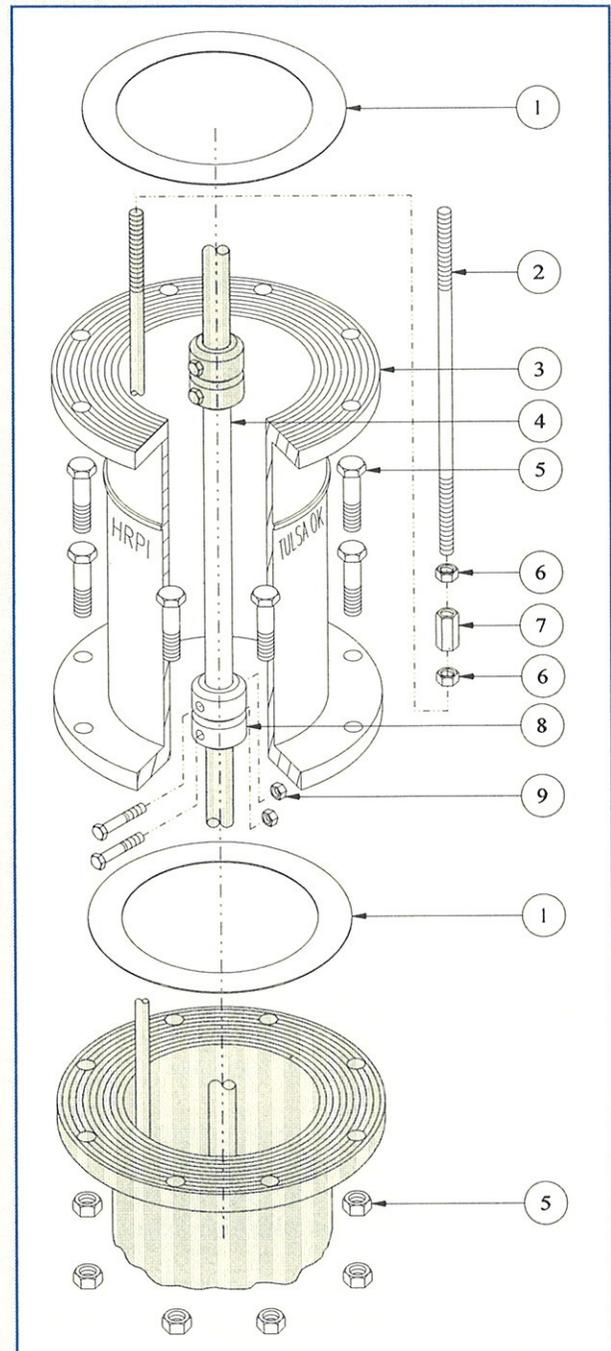

FAX: (918) 224-6857



# Hydrant Repair Parts, Inc.

7900 New Sapulpa Road, Tulsa, OK 74131 • (918) 224-8713

1-800-776-8713 or 1-800-548-9123

## SPECIFICATIONS

ITEM NUMBER	DESCRIPTION	MATERIAL	QTY.
1	Breakable Bolt & Nut	Zinc-Plated Steel	8
2	Safety Flange (HALF CIRCLE)	Cast Iron	2
3	Breakable Stem Coupling	Cast Iron	1
4	Coupling Bolt & Nut	Stainless Steel	2
5	Flange Gasket	Cloth-Inserted SBR Rubber	1

SIZE: 4¼", 4½", or 5¼" Main Valve Opening

HRPI Products are engineered and manufactured using the latest computerized technology to ensure quality products with repeatable tolerances.

HRPI Guarantees this product to be compatible, and will operate with the fire hydrant when installed properly. The use of this product shall not affect any published warranties available to the buyer.

PRODUCTS MEET OR EXCEED THE AWWA C502 STANDARD FOR DRY-BARREL FIRE HYDRANTS.

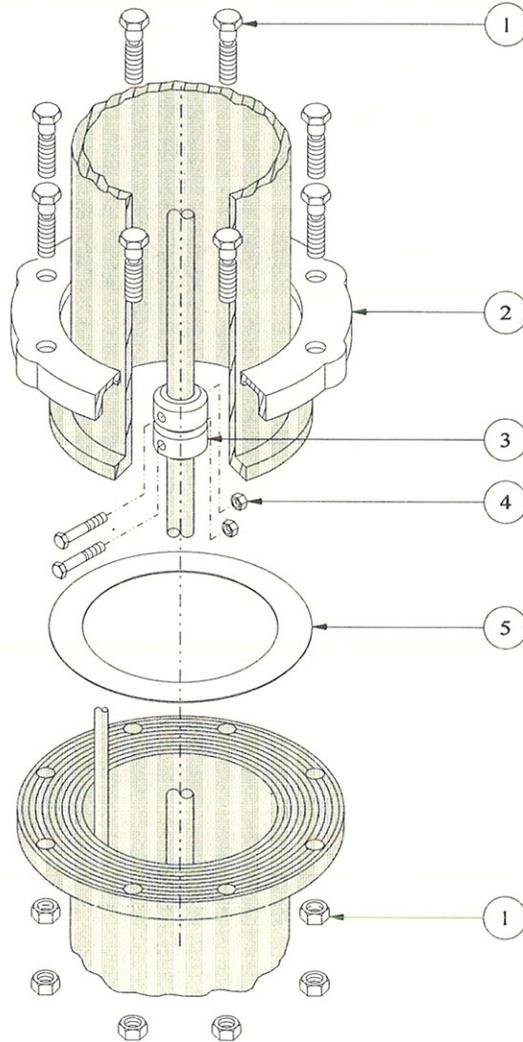

FAX: (918) 224-6857

# Hydrant Repair Parts, Inc.

7900 New Sapulpa Road, Tulsa, OK 74131 • (918) 224-8713

1-800-776-8713 or 1-800-548-9123

Clow is a registered trademark of Clow Valve Co., a division of McWane, Inc., Okaloosa, Iowa.  
Hydrant Repair Parts, Inc., is not affiliated with Clow Valve Co.

## SPECIFICATIONS

ITEM NUMBER	DESCRIPTION	MATERIAL	QTY.
1	Standpipe Gasket	Cloth-Inserted SBR Rubber	2
2	Extension Barrel	Cast Iron or Ductile	1
3	Extension Stem	Steel	1
4	Bolt & Nut	Zinc-Plated Steel	8
5	Extension Stem Coupling	Steel	1
6	Coupling Spring Pin	Stainless Steel	2

SIZE: 4¼", 4½", or 5¼" Main Valve Opening

HRPI Products are engineered and manufactured using the latest computerized technology to ensure quality products with repeatable tolerances.

HRPI Guarantees this product to be compatible, and will operate with the fire hydrant when installed properly. The use of this product shall not affect any published warranties available to the buyer.

PRODUCTS MEET OR EXCEED THE AWWA C502 STANDARD FOR DRY-BARREL FIRE HYDRANTS.

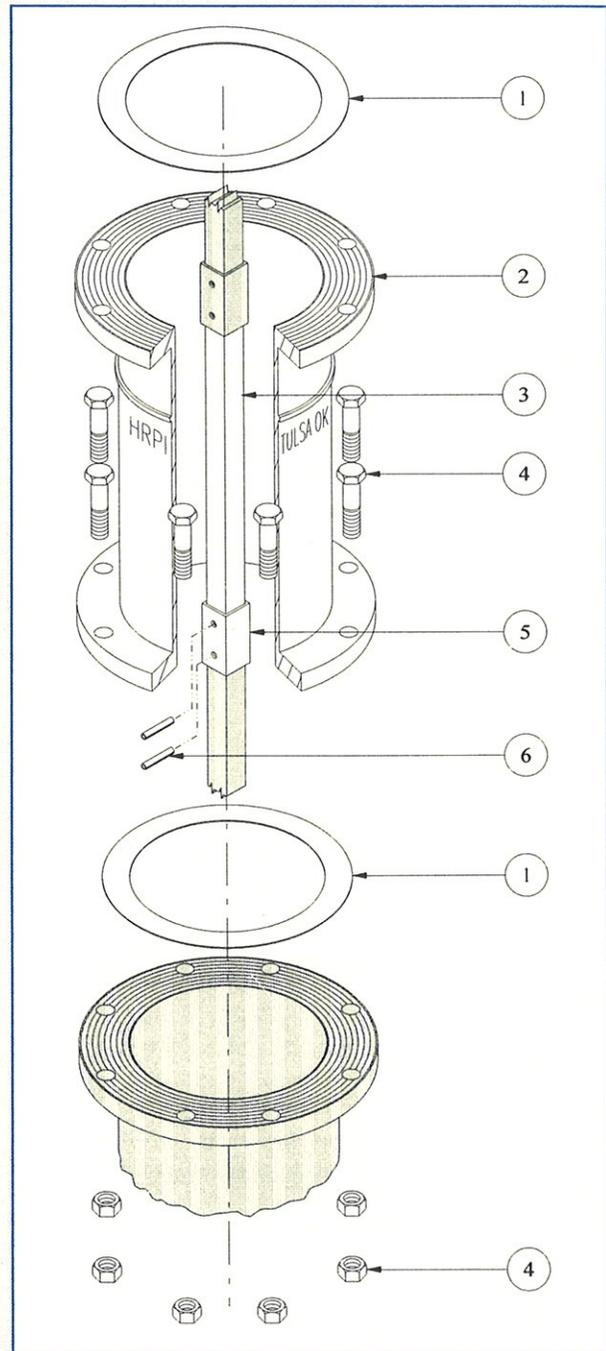

FAX: (918) 224-6857



# Hydrant Repair Parts, Inc.

7900 New Sapulpa Road, Tulsa, OK 74131 • (918) 224-8713

1-800-776-8713 or 1-800-548-9123

Clow is a registered trademark of Clow Valve Co., a division of McWane, Inc., Okaloosa, Iowa. Hydrant Repair Parts, Inc. is not affiliated with Clow Valve Co.



EXTENSION KITS FOR  AMERICAN-DARLING MARK-73 AND B-84-B FIRE HYDRANTS

## SPECIFICATIONS

ITEM NUMBER	DESCRIPTION	MATERIAL	QTY.
1	Flange Gasket	Cloth-Inserted SBR Rubber	2
2	Extension Barrel	Ductile Iron	1
3	Extension Stem	Steel	1
4	Bolt & Nut	Zinc-Plated Steel	8
5	Extension Stem Coupling	Cast Iron	1
6	Clevis Pin	Stainless Steel	2
7	Cotter Pin	Stainless Steel	2

SIZE: 4½" or 5¼" Main Valve Opening

HRPI Products are engineered and manufactured using the latest computerized technology to ensure quality products with repeatable tolerances.

HRPI Guarantees this product to be compatible, and will operate with the fire hydrant when installed properly. The use of this product shall not affect any published warranties available to the buyer.

PRODUCTS MEET OR EXCEED THE AWWA C502 STANDARD FOR DRY-BARREL FIRE HYDRANTS.

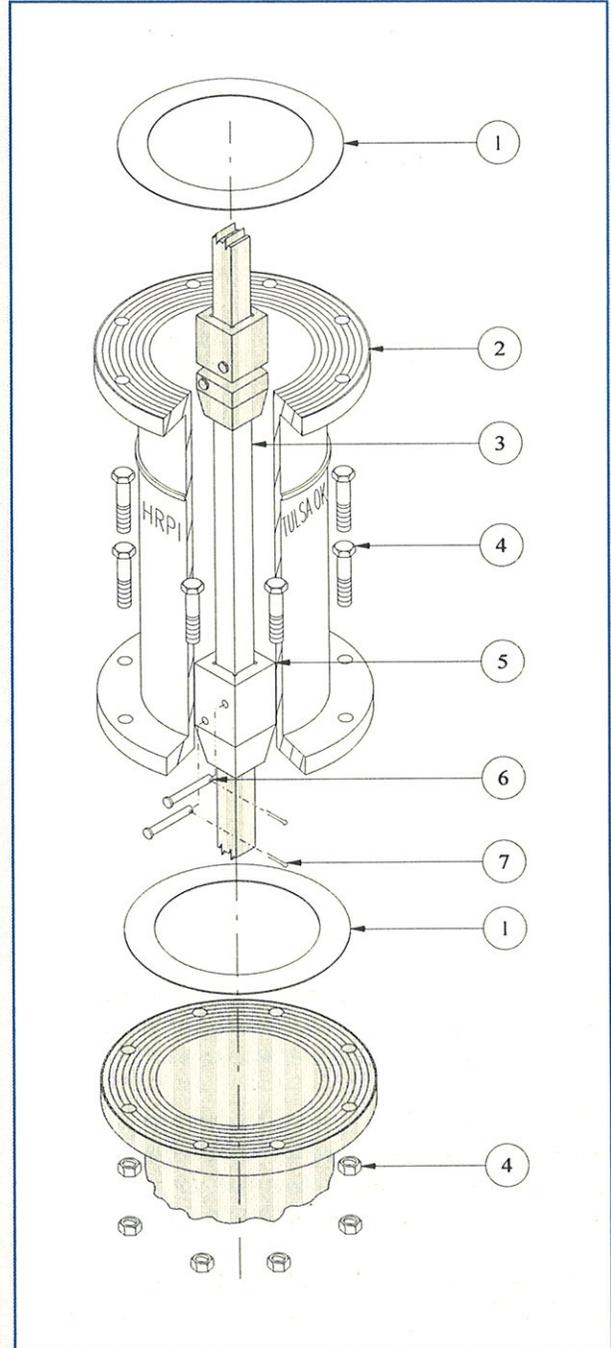

FAX: (918) 224-6857

 **Hydrant Repair Parts, Inc.**  
 7900 New Sapulpa Road, Tulsa, OK 74131 • (918) 224-8713  
 1-800-776-8713 or 1-800-548-9123

TRAFFIC REPAIR KITS FOR  AMERICAN-DARLING MARK-73 AND B-84-B FIRE HYDRANTS

## SPECIFICATIONS

ITEM NUMBER	DESCRIPTION	MATERIAL	QTY.
1	Bolt & Nut	Zinc-Plated Steel	8
2	Breakable Safety Flange (HALF CIRCLE)	Cast Iron	2
3	Breakable Stem Coupling	Cast Iron	1
4	Clevis Pin	Stainless Steel	2
5	Cotter Pin	Stainless Steel	2
6	Flange Gasket	Cloth-Inserted SBR Rubber	1

SIZE: 4½" or 5¼" Main Valve Opening

HRPI Products are engineered and manufactured using the latest computerized technology to ensure quality products with repeatable tolerances.

HRPI Guarantees this product to be compatible, and will operate with the fire hydrant when installed properly. The use of this product shall not affect any published warranties available to the buyer.

PRODUCTS MEET OR EXCEED THE AWWA C502 STANDARD FOR DRY-BARREL FIRE HYDRANTS.

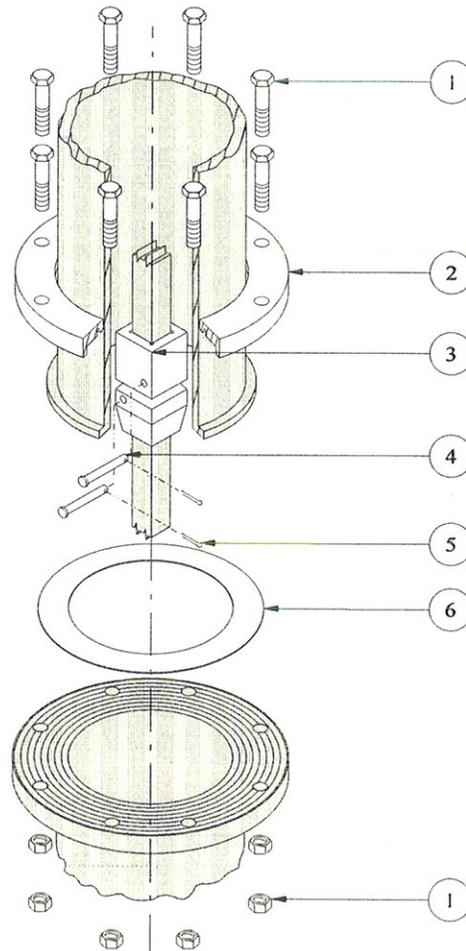

FAX: (918) 224-6857

# Hydrant Repair Parts, Inc.

7900 New Sapulpa Road, Tulsa, OK 74131 • (918) 224-8713

1-800-776-8713 or 1-800-548-9123

American-Darling is a registered trademark of American Flow Control, a division of American Cast Iron Pipe Co., Birmingham, AL.  
Hydrant Repair Parts, Inc. is not affiliated with American Flow Control.

EXTENSION KITS (2'6" AND LONGER) FOR  AMERICAN-DARLING MARK-73 AND B-84-B FIRE HYDRANTS

## SPECIFICATIONS

ITEM NUMBER	DESCRIPTION	MATERIAL	QTY.
1	Flange Gasket	Neoprene	2
2	Extension Barrel	Ductile Pipe	1
3	Extension Stem	Steel	1
4	Bolt & Nut	Zinc-Plated Steel	8
5	Unbreakable Flange	Ductile Iron	2
6	Extension Stem Coupling	Cast Iron	1
7	Snap Ring	Stainless Steel	2
8	Clevis Pin	Stainless Steel	2
9	Cotter Pin	Stainless Steel	2

SIZE: 4½" or 5¼" Main Valve Opening

HRPI Products are engineered and manufactured using the latest computerized technology to ensure quality products with repeatable tolerances.

HRPI Guarantees this product to be compatible, and will operate with the fire hydrant when installed properly. The use of this product shall not affect any published warranties available to the buyer.

PRODUCTS MEET OR EXCEED THE AWWA C502 STANDARD FOR DRY-BARREL FIRE HYDRANTS.

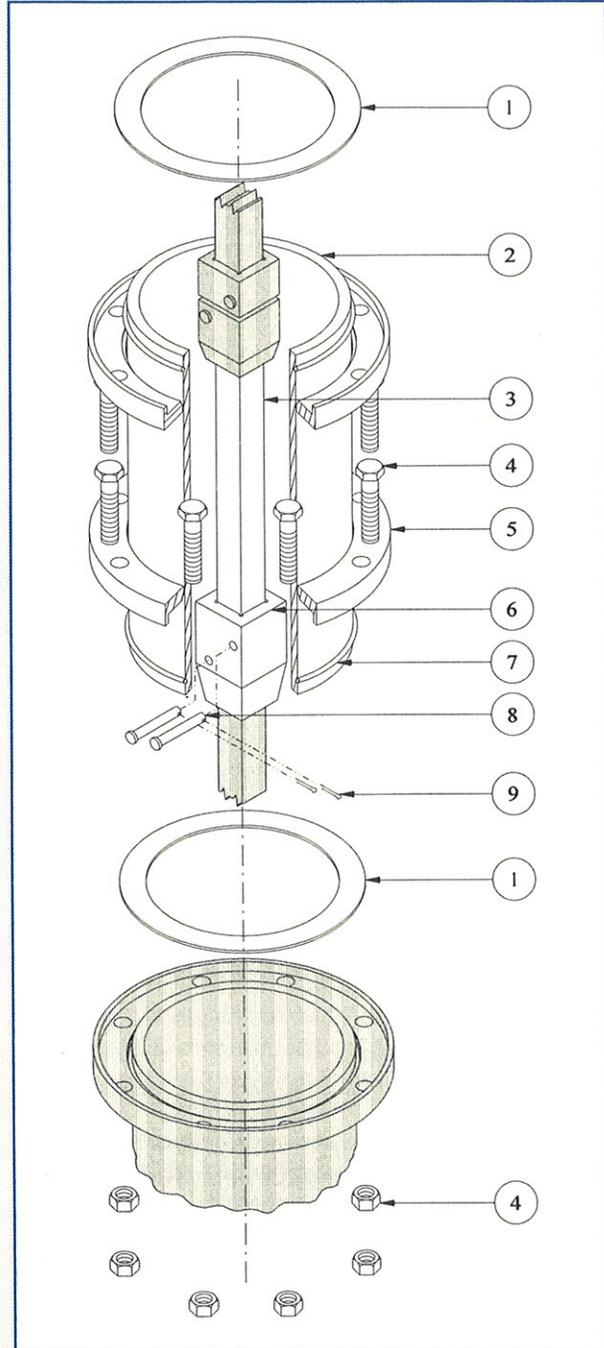

FAX: (918) 224-6857



# Hydrant Repair Parts, Inc.

7900 New Sapulpa Road, Tulsa, OK 74131 • (918) 224-8713

1-800-776-8713 or 1-800-548-9123

American-Darling is a registered trademark of American Flow Control, a division of American Cast Iron Pipe Co., Birmingham, AL.  
Hydrant Repair Parts, Inc., is not affiliated with American Flow Control.



EXTENSION KITS FOR  WATEROUS PACER AND TREND FIRE HYDRANTS

## SPECIFICATIONS

ITEM NUMBER	DESCRIPTION	MATERIAL	QTY.
1	Standpipe Gasket	Molded "L" Neoprene	2
2	Standpipe Extension	Ductile Pipe	1
3	Flange Lock Ring	Stainless Steel	2
4	Standpipe Extension Flange	Ductile	2
5	Extension Stem	Steel	1
6	Bolt & Nut	Zinc-Plated Steel	4
7	Extension Stem Coupling (HALVES)	Steel	2
8	Coupling Bolt & Nut	Stainless Steel	2
9	Hydrant Lubricant	FDA Approved Mineral Oil	1
10	Support Gasket (NOT SHOWN)	Lathe-Cut Buna-N Rubber	2*

\* Note: Item #10 is not required for the Trend hydrant.

SIZE: 5¼" or 4¾" Main Valve Opening

HRPI Products are engineered and manufactured using the latest computerized technology to ensure quality products with repeatable tolerances.

HRPI Guarantees this product to be compatible, and will operate with the fire hydrant when installed properly. The use of this product shall not affect any published warranties available to the buyer.

PRODUCTS MEET OR EXCEED THE AWWA C502 STANDARD FOR DRY-BARREL FIRE HYDRANTS.

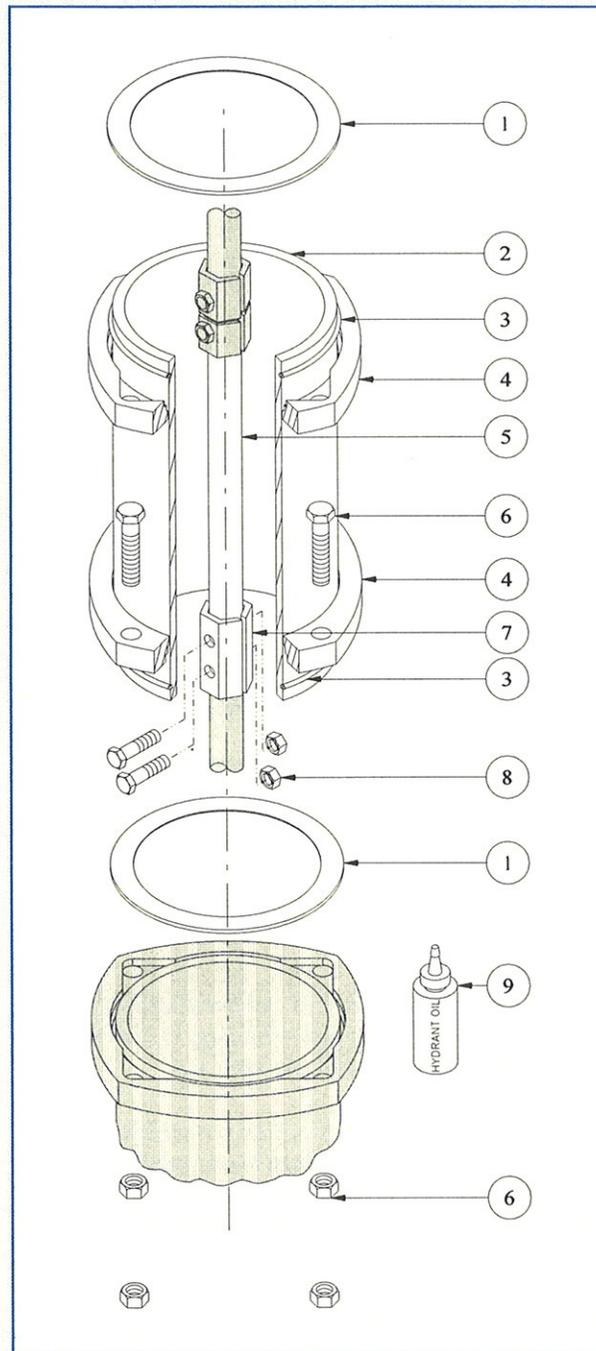

FAX: (918) 224-6857

# Hydrant Repair Parts, Inc.

7900 New Sapulpa Road, Tulsa, OK 74131 • (918) 224-8713

1-800-776-8713 or 1-800-548-9123

TRAFFIC REPAIR KITS FOR  WATEROUS PACER WB-67 AND TREND WB-77 FIRE HYDRANTS

## SPECIFICATIONS

ITEM NUMBER	DESCRIPTION	MATERIAL	QTY.
1	Bolt & Nut	Zinc-Plated Steel	4
2	Breakable Flange	Cast Iron	1
3	Safety Stem Coupling (HALVES)	Steel	2
4	Flange Lock Ring	Stainless Steel	1
5	Coupling Bolt & Nut	Stainless Steel	2*
6	Standpipe Gasket	Molded "L" Neoprene	1
7	Support Gasket (NOT SHOWN)	Lathe-Cut Buna-N Rubber	2**

\* Note: Four nuts are included in kit. Two maybe extra.

\*\* Note: Item #7 is not required for the Trend hydrant.

SIZE: 5¼" or 4¾" Main Valve Opening

HRPI Products are engineered and manufactured using the latest computerized technology to ensure quality products with repeatable tolerances.

HRPI Guarantees this product to be compatible, and will operate with the fire hydrant when installed properly. The use of this product shall not affect any published warranties available to the buyer.

PRODUCTS MEET OR EXCEED THE AWWA C502 STANDARD FOR DRY-BARREL FIRE HYDRANTS.

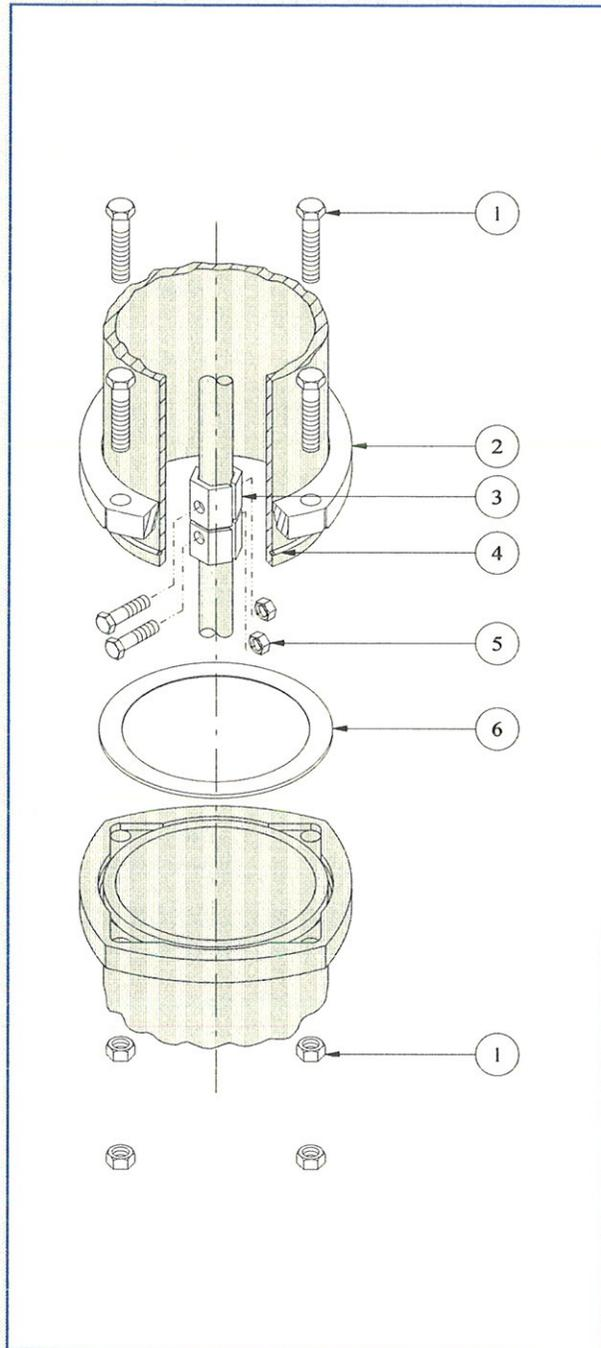

FAX: (918) 224-6857

# Hydrant Repair Parts, Inc.

7900 New Sapulpa Road, Tulsa, OK 74131 • (918) 224-8713

1-800-776-8713 or 1-800-548-9123

Waterous is a registered trademark of American Flow Control, a Division of American Cast Iron Pipe Co., Birmingham, AL.  
Hydrant Repair Parts, Inc., is not affiliated with American Flow Control.

TRAFFIC REPAIR KIT FOR  WATEROUS TREND WT-77  
FIRE HYDRANTS

## SPECIFICATIONS

ITEM NUMBER	DESCRIPTION	MATERIAL	QTY.
1	Bolt & Nut	Zinc-Plated Steel	4
2	Breakable Flange	Cast Iron	1
3	Safety Stem Coupling (HALVES)	Steel	2
4	Coupling Bolt & Nut	Stainless Steel	2*
5	Standpipe Gasket	Molded "L" Neoprene	1
6	Flange Lock Ring	Stainless Steel	1
7	Break Flange Clamp	Cast Iron	4

\*Note: Four nuts are included in kit. Two maybe extra.

SIZE: 4¾" Main Valve Opening

HRPI Products are engineered and manufactured using the latest computerized technology to ensure quality products with repeatable tolerances.

HRPI Guarantees this product to be compatible, and will operate with the fire hydrant when installed properly. The use of this product shall not affect any published warranties available to the buyer.

PRODUCTS MEET OR EXCEED THE AWWA C502 STANDARD FOR DRY-BARREL FIRE HYDRANTS.

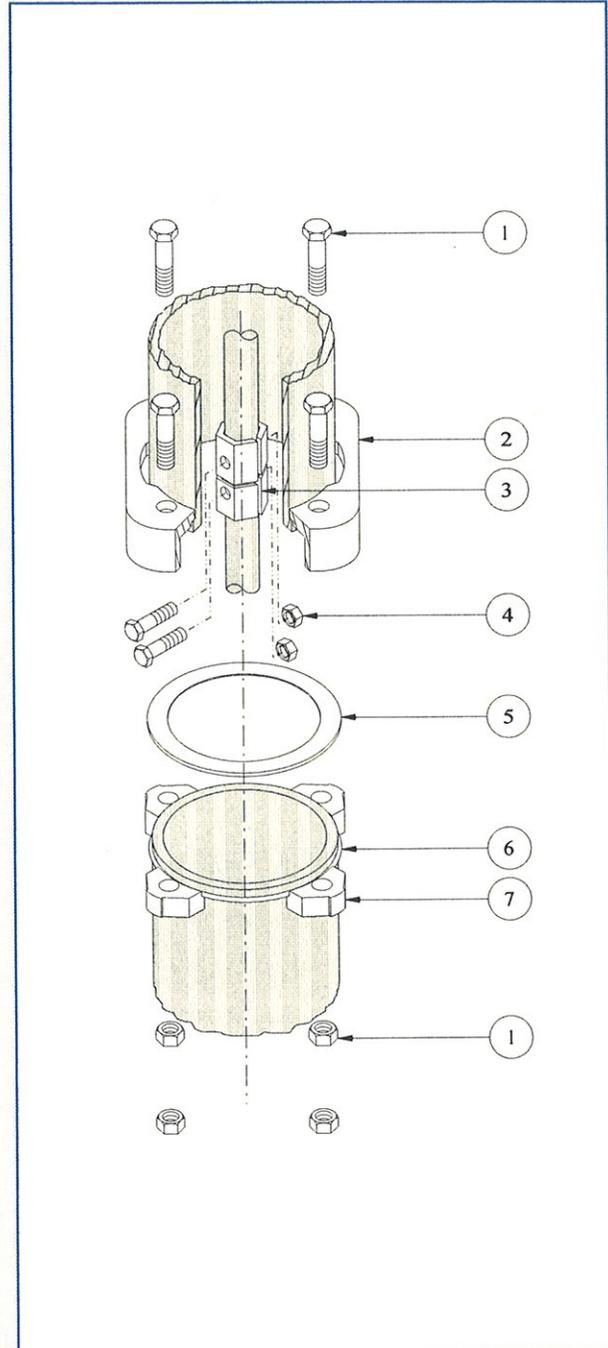

FAX: (918) 224-6857

# Hydrant Repair Parts, Inc.

7900 New Sapulpa Road, Tulsa, OK 74131 • (918) 224-8713

1-800-776-8713 or 1-800-548-9123

Waterous is a registered trademark of American Flow Control, a Division of American Cast Iron Pipe Co., Birmingham, AL.  
Hydrant Repair Parts, Inc., is not affiliated with American Flow Control.



EXTENSION KITS FOR  KENNEDY K81A GUARDIAN FIRE HYDRANTS

## SPECIFICATIONS

ITEM NUMBER	DESCRIPTION	MATERIAL	QTY.
1	Standpipe "O"-Ring	Lathe-Cut Buna-N Rubber	1
2	Extension Barrel	Ductile Iron	1
3	Extension Stem	Steel	1
4	Bolt & Nut	Zinc-Plated Steel	8
5	Extension Stem Coupling	Cast Iron	1
6	Clevis Pin	Stainless Steel	2
7	Cotter Pin	Stainless Steel	2
8	Flange Gasket	Cloth-Inserted SBR Rubber	1
9	Bonnet Gasket (NOT SHOWN)	Cloth-Inserted SBR Rubber	1

SIZE: 4½" or 5¼" Main Valve Opening

HRPI Products are engineered and manufactured using the latest computerized technology to ensure quality products with repeatable tolerances.

HRPI Guarantees this product to be compatible, and will operate with the fire hydrant when installed properly. The use of this product shall not affect any published warranties available to the buyer.

PRODUCTS MEET OR EXCEED THE AWWA C502 STANDARD FOR DRY-BARREL FIRE HYDRANTS.

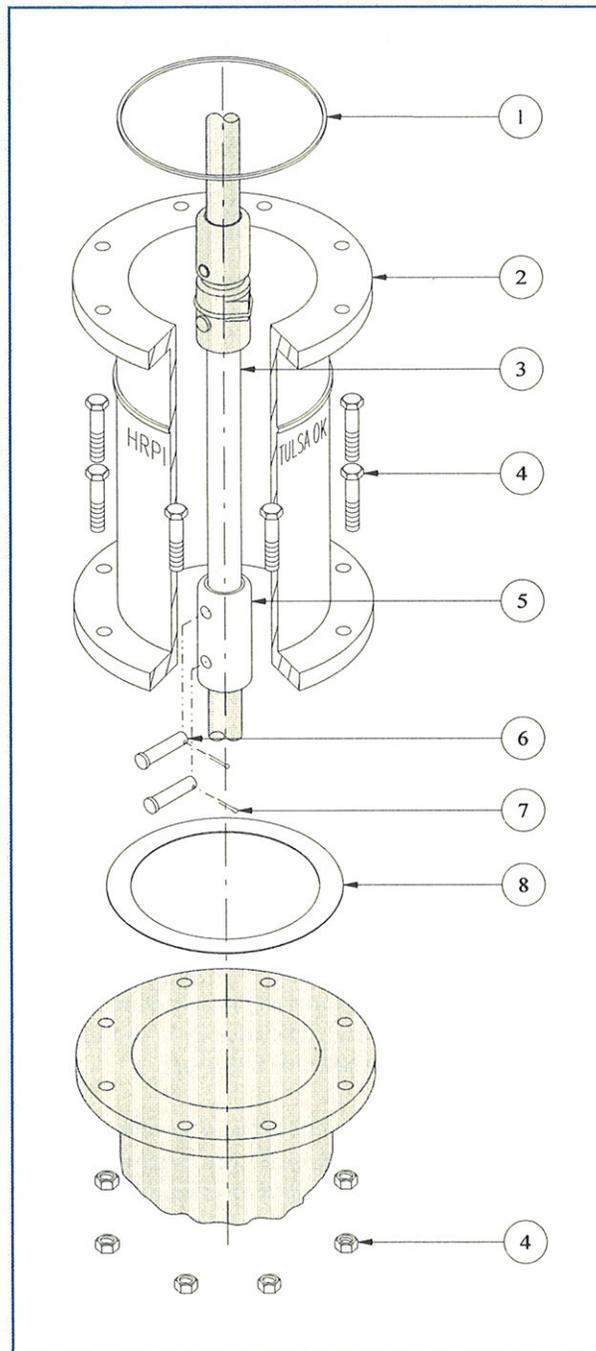

FAX: (918) 224-6857

# Hydrant Repair Parts, Inc.

7900 New Sapulpa Road, Tulsa, OK 74131 • (918) 224-8713

1-800-776-8713 or 1-800-548-9123

Guardian is a registered trademark of Kennedy Valve Co., a division of McWane, Inc., Elmira, NY.  
Hydrant Repair Parts, Inc., is not affiliated with Kennedy Valve Co.

## SPECIFICATIONS

ITEM NUMBER	DESCRIPTION	MATERIAL	QTY.
1	Bolt & Nut	Zinc-Plated Steel	8
2	Breakable Flange (HALF-CIRCLE)	Cast Iron	2
3	Breakable Stem Coupling	Cast Iron	1
4	Clevis Pin	Stainless Steel	2
5	Cotter Pin	Stainless Steel	2
6	Standpipe "O"-Ring	Lathe-Cut Buna-N Rubber	1
7	Bonnet Gasket (NOT SHOWN)	Cloth-Inserted SBR Rubber	1

SIZE: 4½" or 5¼" Main Valve Opening

HRPI Products are engineered and manufactured using the latest computerized technology to ensure quality products with repeatable tolerances.

HRPI Guarantees this product to be compatible, and will operate with the fire hydrant when installed properly. The use of this product shall not affect any published warranties available to the buyer.

PRODUCTS MEET OR EXCEED THE AWWA C502 STANDARD FOR DRY-BARREL FIRE HYDRANTS.

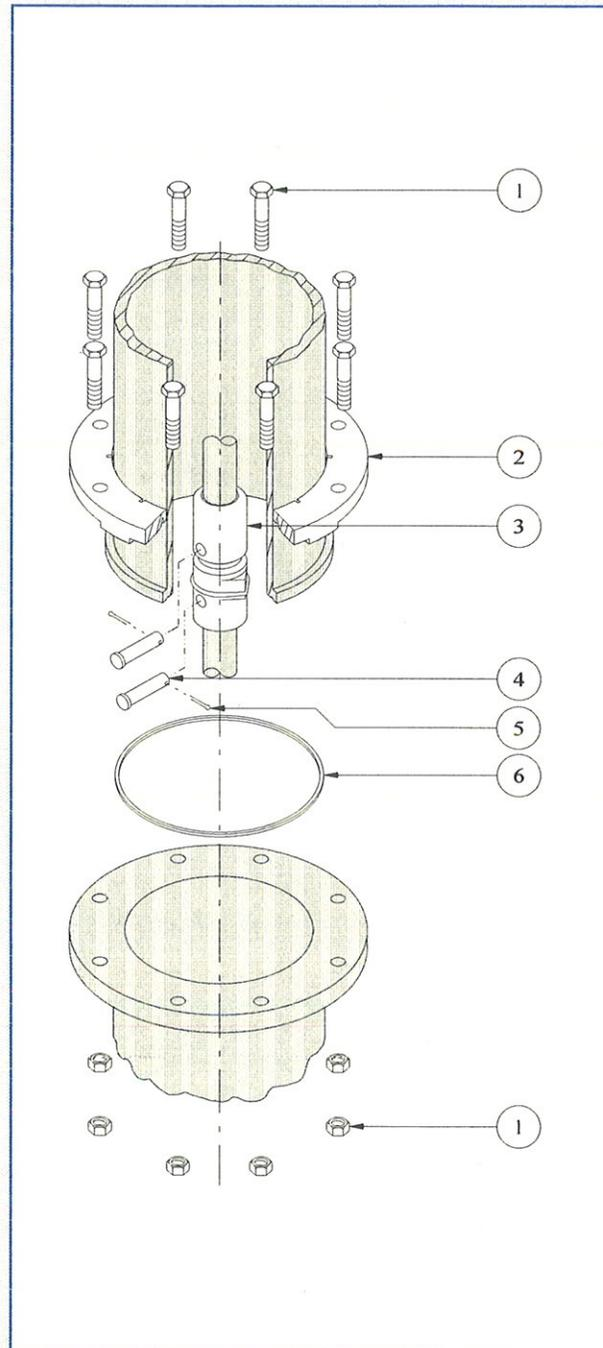

FAX: (918) 224-6857

# Hydrant Repair Parts, Inc.

7900 New Sapulpa Road, Tulsa, OK 74131 • (918) 224-8713

1-800-776-8713 or 1-800-548-9123

Guardian is a registered trademark of Kennedy Valve Co., a division of McWane, Inc., Elmira, NY.  
Hydrant Repair Parts, Inc. is not affiliated with Kennedy Valve Co.

EXTENSION KITS FOR  M & H 129 (OLD STYLE) FIRE HYDRANTS

## SPECIFICATIONS

ITEM NUMBER	DESCRIPTION	MATERIAL	QTY.
1	Flange Gasket	Cloth-Inserted SBR Rubber	2
2	Extension Barrel	Ductile Iron	1
3	Extension Stem	Steel	1
4	Non-Breakable Bolt & Nut	Zinc-Plated Steel	8
5	Extension Stem Coupling	Cast Iron	1
6	Coupling Bolt & Nut	Stainless Steel	2

SIZE: 4½" or 5¼" Main Valve Opening

HRPI Products are engineered and manufactured using the latest computerized technology to ensure quality products with repeatable tolerances.

HRPI Guarantees this product to be compatible, and will operate with the fire hydrant when installed properly. The use of this product shall not affect any published warranties available to the buyer.

PRODUCTS MEET OR EXCEED THE AWWA C502 STANDARD FOR DRY-BARREL FIRE HYDRANTS.

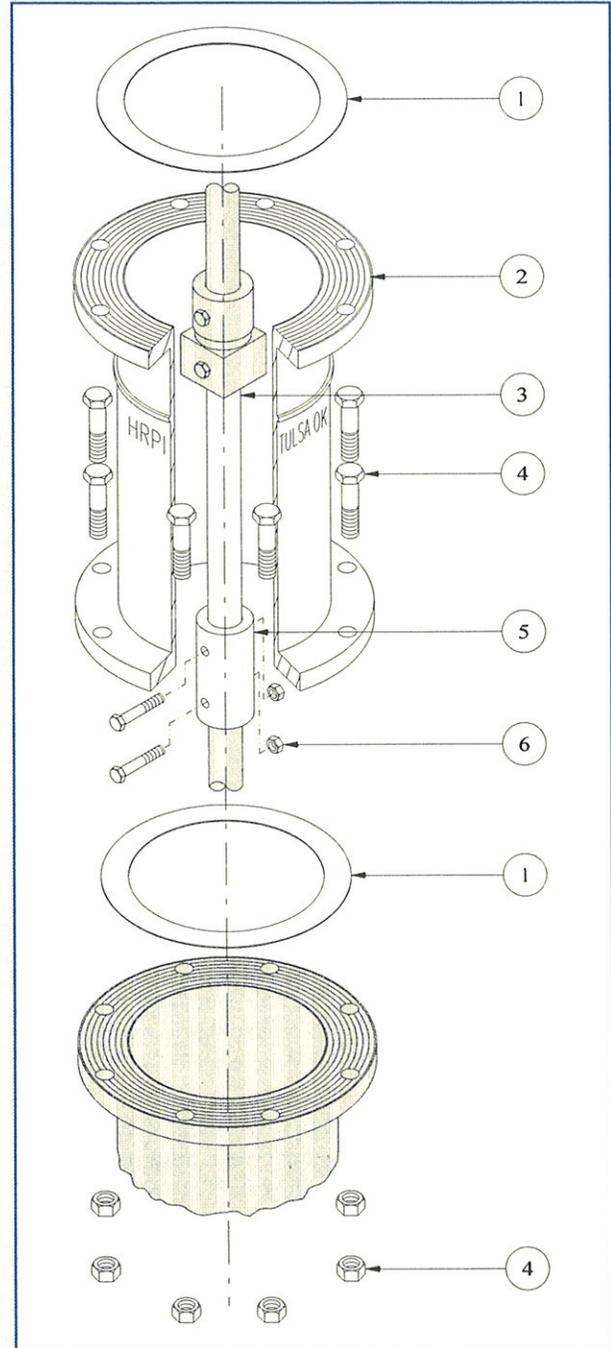

FAX: (918) 224-6857



# Hydrant Repair Parts, Inc.

7900 New Sapulpa Road, Tulsa, OK 74131 • (918) 224-8713

1-800-776-8713 or 1-800-548-9123

## SPECIFICATIONS

ITEM NUMBER	DESCRIPTION	MATERIAL	QTY.
1	Breakable Bolt & Nut	Zinc-Plated Steel	8
2A	Round, Breakable Stem Coupling (OLD STYLE)	Cast Iron	1*
2B	Square, Breakable Stem Coupling (NEW STYLE)	Cast Iron	1*
3	Coupling Bolt & Nut	Stainless Steel	2
4	Flange Gasket	Cloth-Inserted SBR Rubber	1

\*Note: When ordering, specify whether round or square coupling.

SIZE: 4½" or 5¼" Main Valve Opening

HRPI Products are engineered and manufactured using the latest computerized technology to ensure quality products with repeatable tolerances.

HRPI Guarantees this product to be compatible, and will operate with the fire hydrant when installed properly. The use of this product shall not affect any published warranties available to the buyer.

PRODUCTS MEET OR EXCEED THE AWWA C502 STANDARD FOR DRY-BARREL FIRE HYDRANTS.

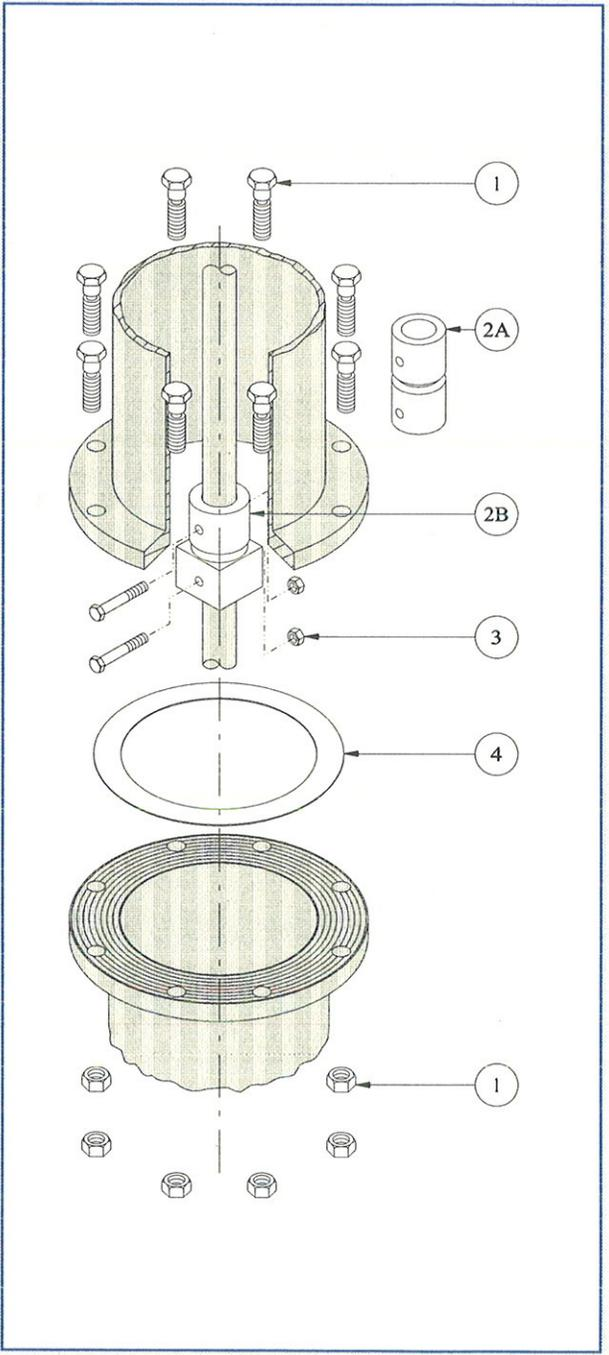

FAX: (918) 224-6857

# Hydrant Repair Parts, Inc.

7900 New Sapulpa Road, Tulsa, OK 74131 • (918) 224-8713

1-800-776-8713 or 1-800-548-9123

M & H is a registered trademark of the M&H Valve Co., a division of McWane, Inc., Anniston, AL.  
Hydrant Repair Parts, Inc., is not affiliated with the M&H Valve Co.

EXTENSION KITS FOR  M & H 929  
FIRE HYDRANTS

## SPECIFICATIONS

ITEM NUMBER	DESCRIPTION	MATERIAL	QTY.
①	Extension Barrel	Ductile Iron	1
②	Extension Stem	Steel	1
③	Bolt & Nut	Zinc-Plated Steel	6
④	Extension Stem Coupling	Cast Iron	1
⑤	Coupling Bolt & Nut	Stainless Steel	2
⑥	Extension "O"-Ring	Buna-N Rubber	1
⑦	Extension Lug	Cast Iron	6

SIZE: 4½" and 5¼" Main Valve Opening

HRPI Products are engineered and manufactured using the latest computerized technology to ensure quality products with repeatable tolerances.

HRPI Guarantees this product to be compatible, and will operate with the fire hydrant when installed properly. The use of this product shall not affect any published warranties available to the buyer.

PRODUCTS MEET OR EXCEED THE AWWA C502 STANDARD FOR DRY-BARREL FIRE HYDRANTS.

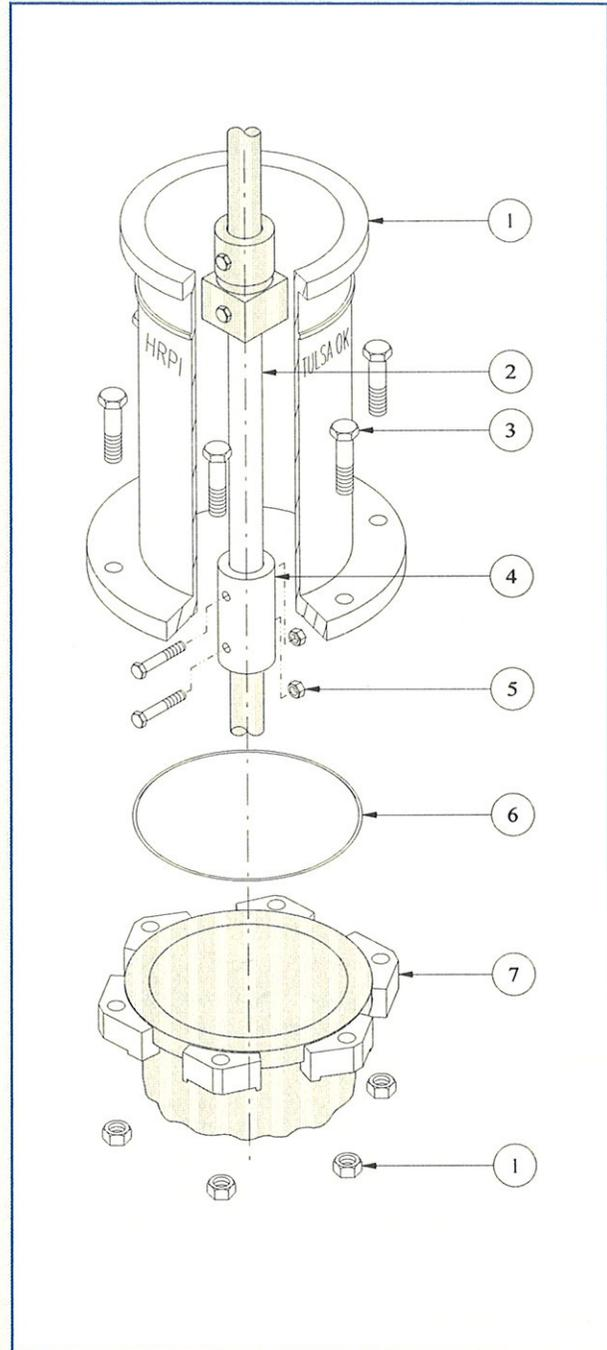

FAX: (918) 224-6857

# Hydrant Repair Parts, Inc.

7900 New Sapulpa Road, Tulsa, OK 74131 • (918) 224-8713

1-800-776-8713 or 1-800-548-9123

## SPECIFICATIONS

ITEM NUMBER	DESCRIPTION	MATERIAL	QTY.
1	Bolt & Nut	Zinc-Plated Steel	6
2	Breakable Stem Coupling	Cast Iron	1
3	Coupling Bolt & Nut	Stainless Steel	2
4	Extension "O"-Ring	Buna-N Rubber	1
5	Breakable Lug	Cast Iron	6

SIZE: 4½" and 5¼" Main Valve Opening

HRPI Products are engineered and manufactured using the latest computerized technology to ensure quality products with repeatable tolerances.

HRPI Guarantees this product to be compatible, and will operate with the fire hydrant when installed properly. The use of this product shall not affect any published warranties available to the buyer.

PRODUCTS MEET OR EXCEED THE AWWA C502 STANDARD FOR DRY-BARREL FIRE HYDRANTS.

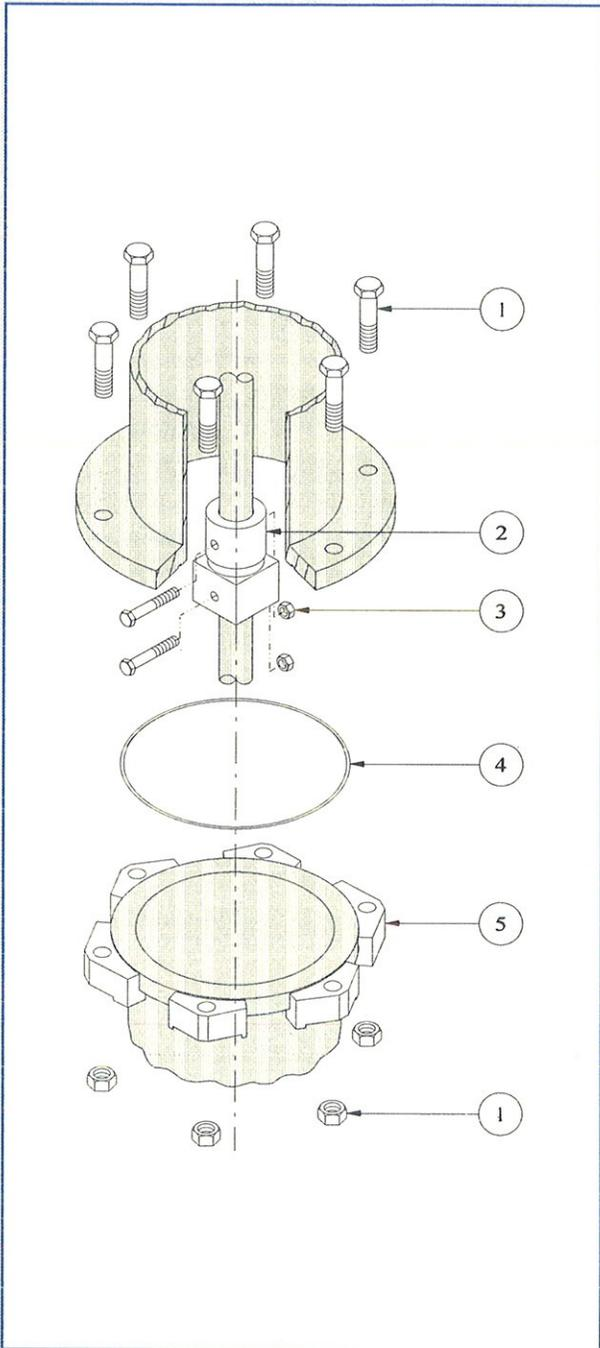

FAX: (918) 224-6857

# Hydrant Repair Parts, Inc.

7900 New Sapulpa Road, Tulsa, OK 74131 • (918) 224-8713

1-800-776-8713 or 1-800-548-9123

M & H is a registered trademark of the M&H Valve Co., a division of McWane, Inc., Anniston, AL.  
Hydrant Repair Parts, Inc. is not affiliated with the M&H Valve Co.

EXTENSION KITS FOR  M & H 6-129 (NEW STYLE) FIRE HYDRANTS

## SPECIFICATIONS

ITEM NUMBER	DESCRIPTION	MATERIAL	QTY.
1	Flange "O"-Ring	Buna-N Rubber	1
2	Extension Barrel	Ductile Iron	1
3	Extension Stem	Steel	1
4	Non-Breakable Bolt & Nut	Zinc-Plated Steel	8
5	Extension Stem Coupling	Cast Iron	1
6	Coupling Bolt & Nut	Stainless Steel	2
7	Flange Gasket	Cloth-Inserted SBR Rubber	2
8	Extension Flange (HALF-CIRCLE)	Ductile Iron	2
9*	Breakable Bolt & Nut (NOT SHOWN)	Zinc-Plated Steel	8

SIZE: 4½" or 5¼" Main Valve Opening

\*Required when installing on M & H 129 (Old Style) fire hydrant.

HRPI Products are engineered and manufactured using the latest computerized technology to ensure quality products with repeatable tolerances.

HRPI Guarantees this product to be compatible, and will operate with the fire hydrant when installed properly. The use of this product shall not affect any published warranties available to the buyer.

PRODUCTS MEET OR EXCEED THE AWWA C502 STANDARD FOR DRY-BARREL FIRE HYDRANTS.

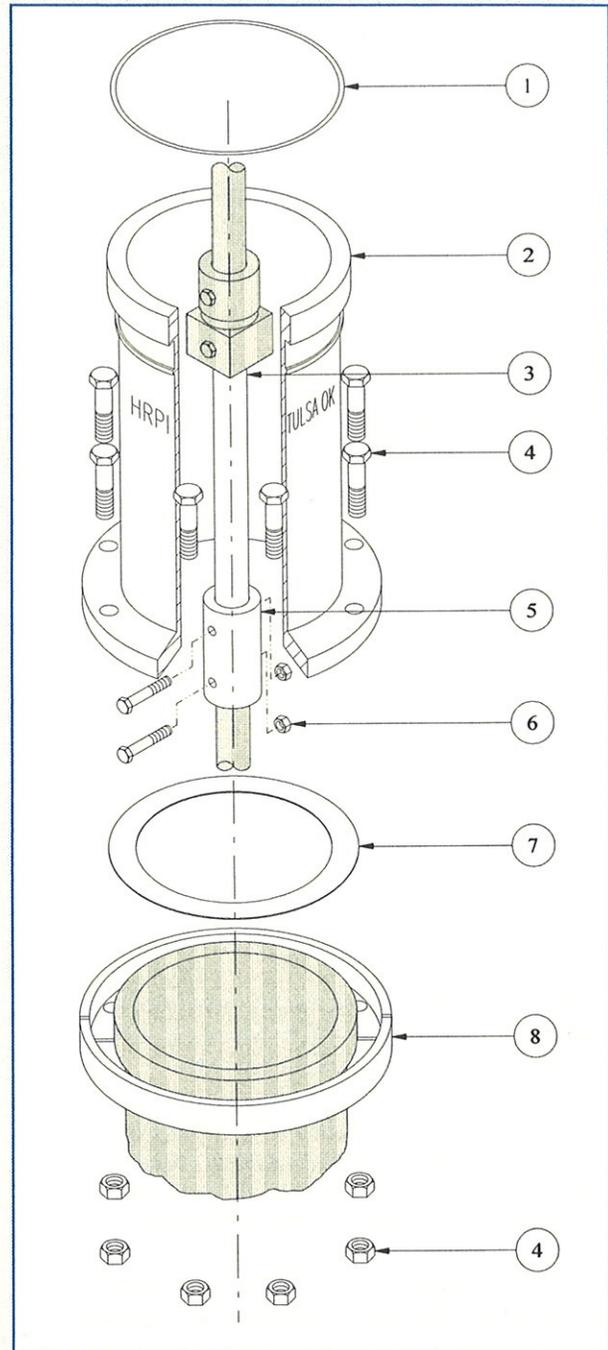

FAX: (918) 224-6857

# Hydrant Repair Parts, Inc.

7900 New Sapulpa Road, Tulsa, OK 74131 • (918) 224-8713

1-800-776-8713 or 1-800-548-9123

## SPECIFICATIONS

ITEM NUMBER	DESCRIPTION	MATERIAL	QTY.
1	Non-Breakable Bolt & Nut	Zinc-Plated Steel	8
2	Safety Stem Coupling	Cast Iron	1
3	Coupling Bolt & Nut	Stainless Steel	2
4	Flange "O"-Ring	Buna-N Rubber	1
5	Safety Flange (HALF-CIRCLE)	Cast Iron	2

SIZE: 4½" or 5¼" Main Valve Opening

HRPI Products are engineered and manufactured using the latest computerized technology to ensure quality products with repeatable tolerances.

HRPI Guarantees this product to be compatible, and will operate with the fire hydrant when installed properly. The use of this product shall not affect any published warranties available to the buyer.

PRODUCTS MEET OR EXCEED THE AWWA C502 STANDARD FOR DRY-BARREL FIRE HYDRANTS.

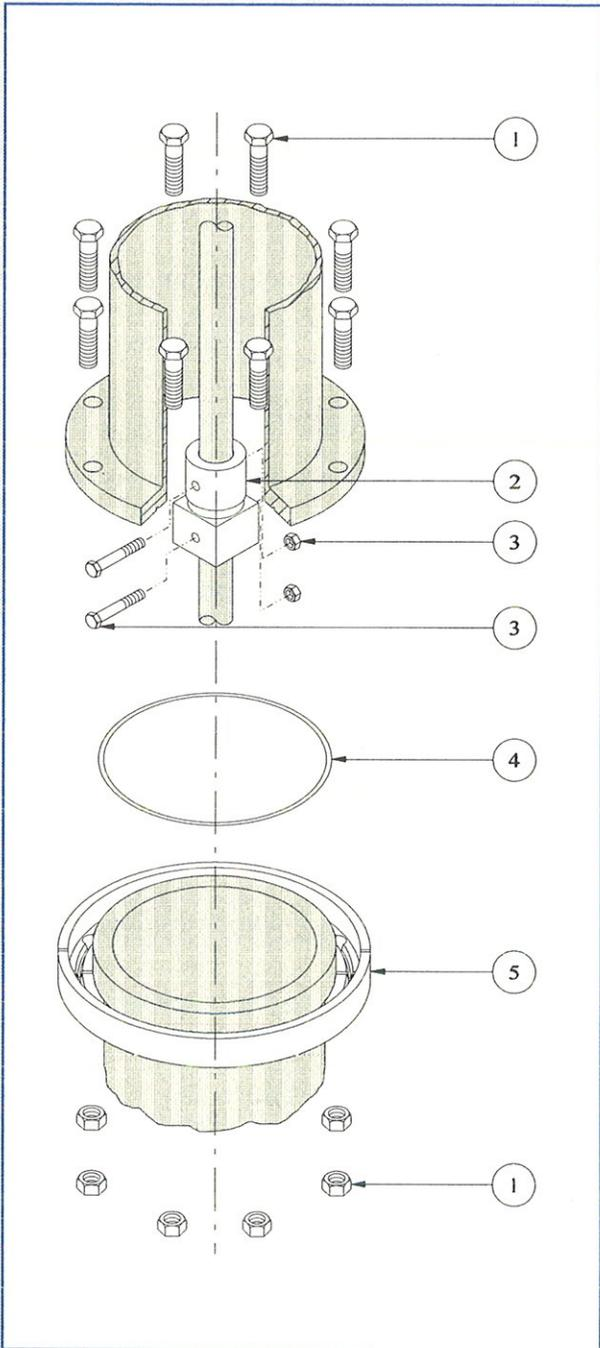

FAX: (918) 224-6857

# Hydrant Repair Parts, Inc.

7900 New Sapulpa Road, Tulsa, OK 74131 • (918) 224-8713

1-800-776-8713 or 1-800-548-9123

M & H is a registered trademark of the M&H Valve Co., a division of McWane, Inc., Anniston, AL.  
Hydrant Repair Parts, Inc., is not affiliated with the M&H Valve Co.

EXTENSION KITS FOR  U.S. PIPE METROPOLITAN AND SENTINEL FIRE HYDRANTS

## SPECIFICATIONS

ITEM NUMBER	DESCRIPTION	MATERIAL	QTY.
1	Standpipe Coupling Seal	Lathe-Cut Buna-N Rubber	1
2	Standpipe Extension	Ductile Pipe	1
3	Extension Stem	Steel	1
4	Extension Stem Coupling	Cast Iron	1
5	Extension Standpipe Coupling (HALF CIRCLE)	Ductile	2
6	Standpipe Coupling Bolt & Nut	Stainless Steel	2
7	Clevis Pin	Stainless Steel	2
8	Cotter Pin	Stainless Steel	2
9	Standpipe Coupling Gasket	Nitrile	1

SIZE: 4½" or 5¼" Main Valve Opening

HRPI Products are engineered and manufactured using the latest computerized technology to ensure quality products with repeatable tolerances.

HRPI Guarantees this product to be compatible, and will operate with the fire hydrant when installed properly. The use of this product shall not affect any published warranties available to the buyer.

PRODUCTS MEET OR EXCEED THE AWWA C502 STANDARD FOR DRY-BARREL FIRE HYDRANTS.

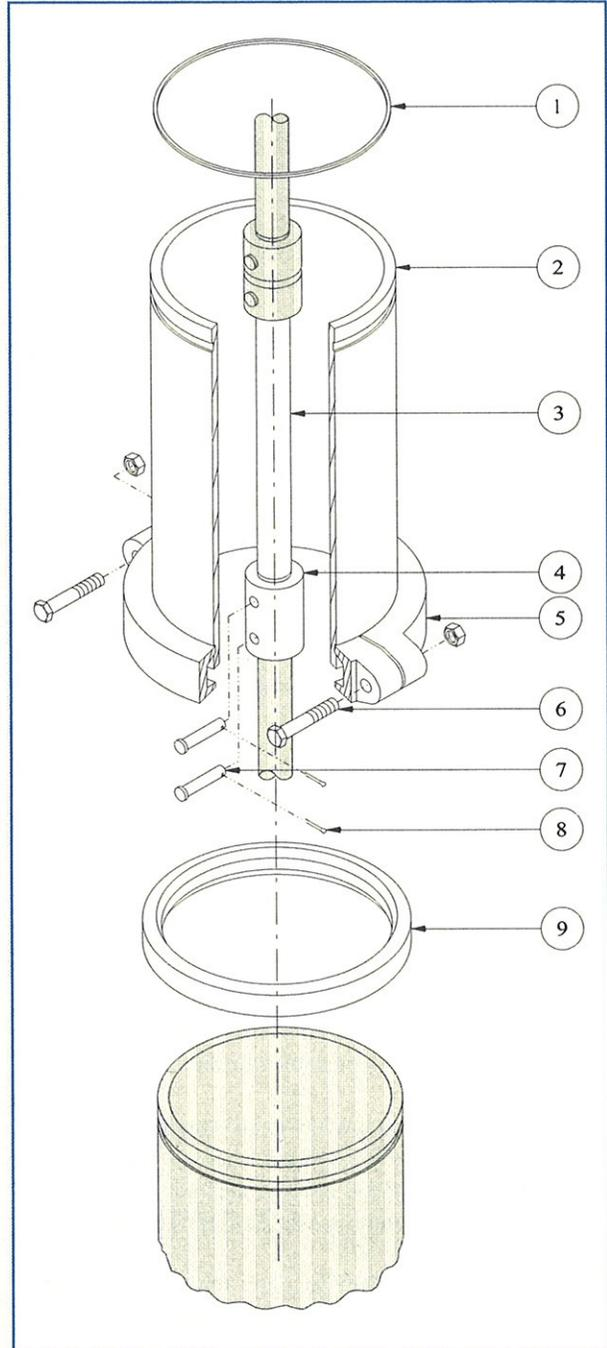

FAX: (918) 224-6857

 **Hydrant Repair Parts, Inc.**  
7900 New Sapulpa Road, Tulsa, OK 74131 • (918) 224-8713  
1-800-776-8713 or 1-800-548-9123

## SPECIFICATIONS

ITEM NUMBER	DESCRIPTION	MATERIAL	QTY.
1	Breakable Stem Coupling	Cast Iron	1
2	Breakable Standpipe Coupling (HALF CIRCLE)	Cast Iron	2
3	Standpipe Coupling Bolt & Nut	Stainless Steel	2
4	Clevis Pin	Stainless Steel	2
5	Cotter Pin	Stainless Steel	2
6	Standpipe Coupling Seal	Lathe-Cut Buna-N Rubber	1
7	Bonnet Seal (NOT SHOWN)	Lathe-Cut Buna-N Rubber	1

SIZE: 5 1/4" Main Valve Opening

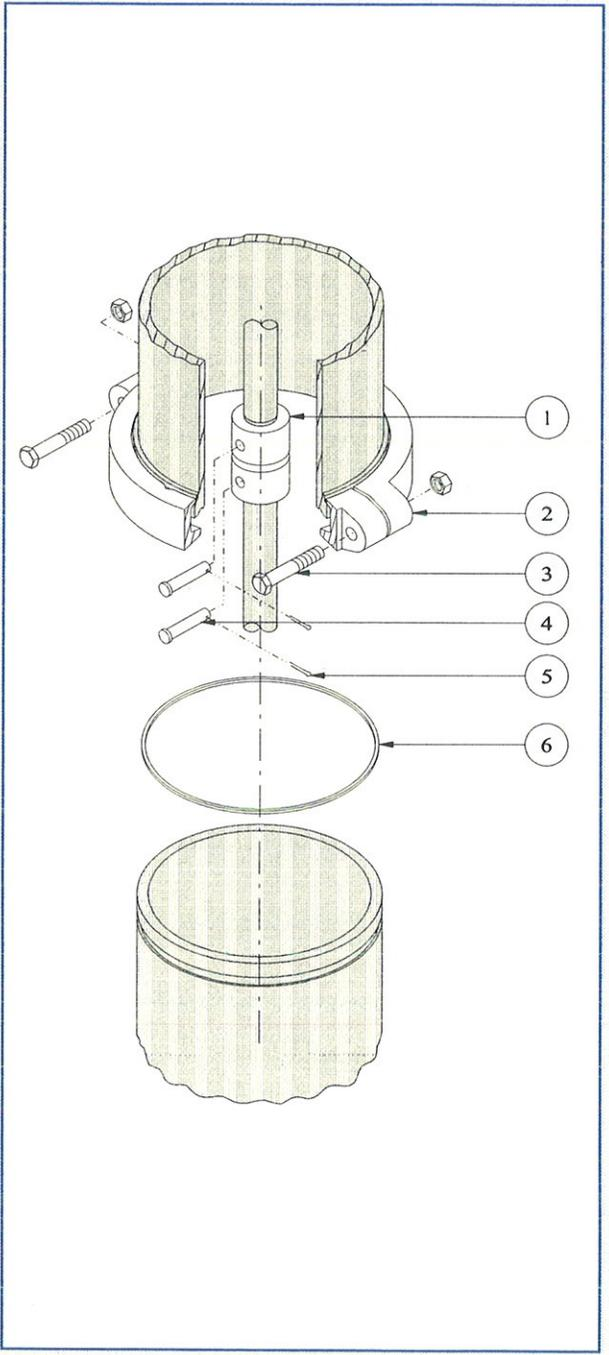

HRPI Products are engineered and manufactured using the latest computerized technology to ensure quality products with repeatable tolerances.

HRPI Guarantees this product to be compatible, and will operate with the fire hydrant when installed properly. The use of this product shall not affect any published warranties available to the buyer.

PRODUCTS MEET OR EXCEED THE AWWA C502 STANDARD FOR DRY-BARREL FIRE HYDRANTS.



FAX: (918) 224-6857

# Hydrant Repair Parts, Inc.

7900 New Sapulpa Road, Tulsa, OK 74131 • (918) 224-8713

1-800-776-8713 or 1-800-548-9123  
U.S. Pipe is a registered trademark of U.S. Pipe & Foundry Co., Birmingham, AL.  
 Hydrant Repair Parts, Inc., is not affiliated with U.S. Pipe & Foundry Co.

EXTENSION KITS FOR  U.S. PIPE H200 & H205 FIRE HYDRANTS

## SPECIFICATIONS

ITEM NUMBER	DESCRIPTION	MATERIAL	QTY.
1	Standpipe "O"-Ring	Lathe-Cut Buna-N Rubber	2
2	Extension Barrel	Cast Iron or Ductile	1
3	Extension Stem	Steel	1
4	Bolt & Nut	Zinc-Plated Steel	8
5	Extension Stem Coupling	Cast Iron	1
6	Coupling Bolt & Nut	Stainless Steel	2
7	Standpipe Extension Flange (HALF CIRCLE)	Ductile Iron	2

SIZE: 4 $\frac{3}{8}$ " or 5 $\frac{1}{4}$ " Main Valve Opening

HRPI Products are engineered and manufactured using the latest computerized technology to ensure quality products with repeatable tolerances.

HRPI Guarantees this product to be compatible, and will operate with the fire hydrant when installed properly. The use of this product shall not affect any published warranties available to the buyer.

PRODUCTS MEET OR EXCEED THE AWWA C502 STANDARD FOR DRY-BARREL FIRE HYDRANTS.

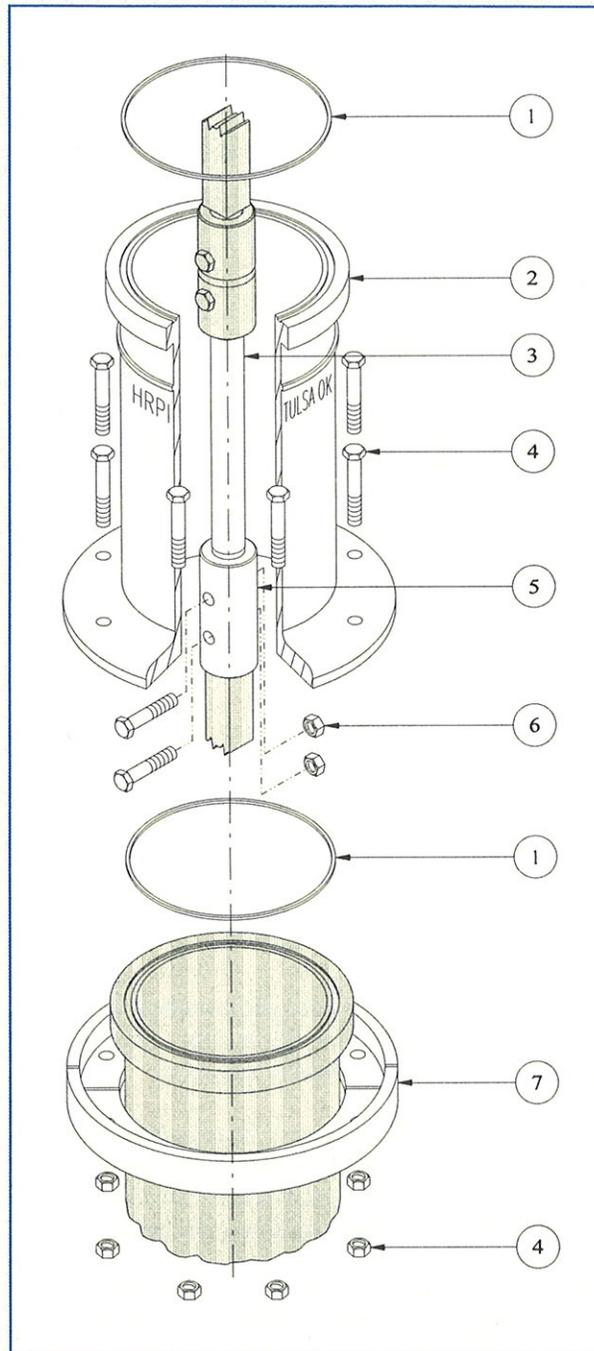

FAX: (918) 224-6857

# Hydrant Repair Parts, Inc.

7900 New Sapulpa Road, Tulsa, OK 74131 • (918) 224-8713

1-800-776-8713 or 1-800-548-9123

U.S. Pipe is a registered trademark of U.S. Pipe & Foundry Co., Birmingham, AL.  
Hydrant Repair Parts, Inc., is not affiliated with U.S. Pipe & Foundry Co.

## SPECIFICATIONS

ITEM NUMBER	DESCRIPTION	MATERIAL	QTY.
①	Bolt & Nut	Zinc-Plated Steel	8
②	Breakable Stem Coupling	Cast Iron	1
③	Coupling Bolt & Nut	Stainless Steel	2
④	Standpipe "O"-Ring	Lathe-Cut Buna-N Rubber	1
⑤	Standpipe Safety Flange (HALF CIRCLE)	Cast Iron	2

SIZE: 4 7/8" or 5 1/4" Main Valve Opening

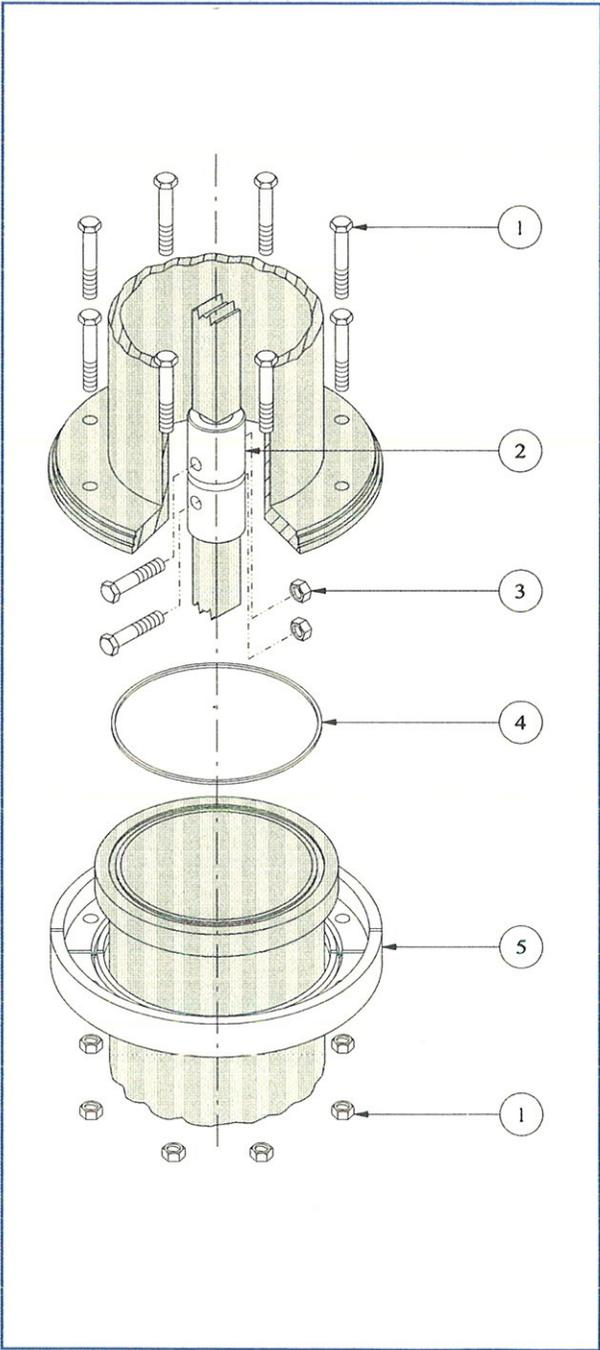

HRPI Products are engineered and manufactured using the latest computerized technology to ensure quality products with repeatable tolerances.

HRPI Guarantees this product to be compatible, and will operate with the fire hydrant when installed properly. The use of this product shall not affect any published warranties available to the buyer.

PRODUCTS MEET OR EXCEED THE AWWA C502 STANDARD FOR DRY-BARREL FIRE HYDRANTS.



FAX: (918) 224-6857

# Hydrant Repair Parts, Inc.

7900 New Sapulpa Road, Tulsa, OK 74131 • (918) 224-8713

1-800-776-8713 or 1-800-548-9123

U.S. Pipe is a registered trademark of U.S. Pipe & Foundry Co., Birmingham, AL.  
Hydrant Repair Parts, Inc., is not affiliated with U.S. Pipe & Foundry Co.

EXTENSION KITS FOR  U.S. PIPE M-94 FIRE HYDRANTS

## SPECIFICATIONS

ITEM NUMBER	DESCRIPTION	MATERIAL	QTY.
1	Standpipe Extension	Ductile Pipe	1
2	Extension Stem	Steel	1
3	Extension Stem Coupling	Cast Iron	1
4	Extension Standpipe Coupling (HALF CIRCLE)	Ductile	2
5	Standpipe Coupling Bolt & Nut	Stainless Steel	2
6	Clevis Pin	Stainless Steel	2
7	Cotter Pin	Stainless Steel	2
8	Standpipe Coupling Seal	Lathe-Cut Buna-N Rubber	1
9	Stem Dampener "O"-Ring (Not Shown)	Buna-N Rubber	1

SIZE: 4½" or 5¼" Main Valve Opening

HRPI Products are engineered and manufactured using the latest computerized technology to ensure quality products with repeatable tolerances.

HRPI Guarantees this product to be compatible, and will operate with the fire hydrant when installed properly. The use of this product shall not affect any published warranties available to the buyer.

PRODUCTS MEET OR EXCEED THE AWWA C502 STANDARD FOR DRY-BARREL FIRE HYDRANTS.

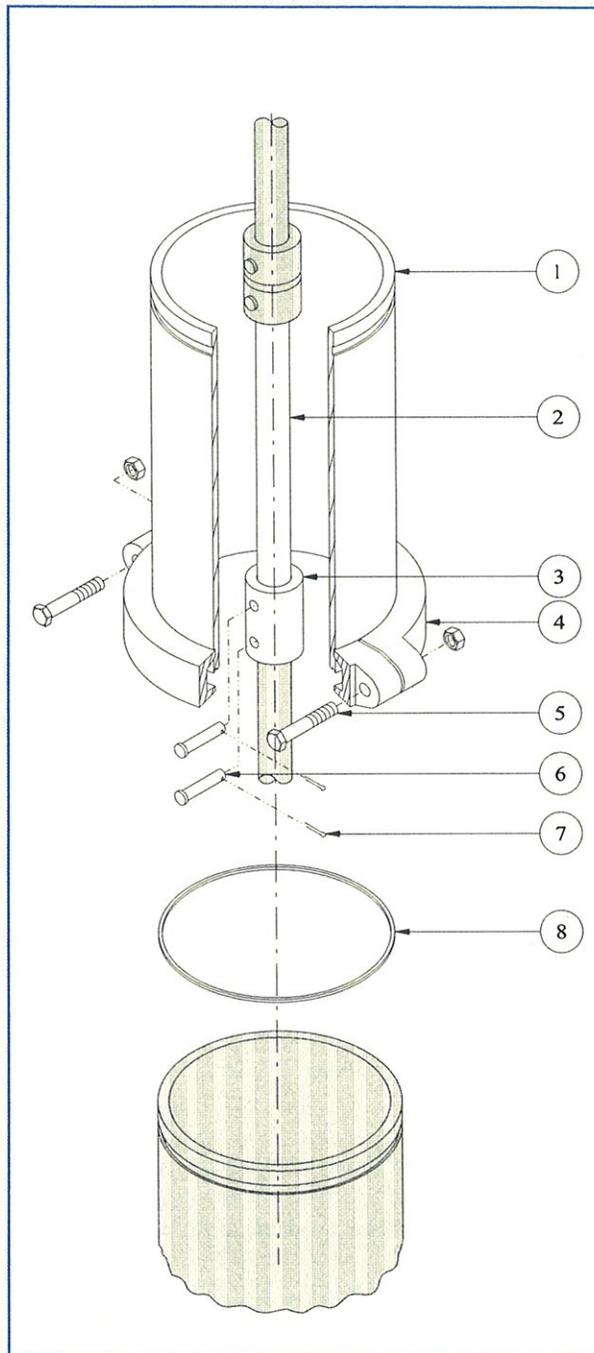

FAX: (918) 224-6857

# Hydrant Repair Parts, Inc.

7900 New Sapulpa Road, Tulsa, OK 74131 • (918) 224-8713

1-800-776-8713 or 1-800-548-9123

U.S. Pipe is a registered trademark of U.S. Pipe & Foundry Co., Birmingham, AL.  
Hydrant Repair Parts, Inc. is not affiliated with U.S. Pipe & Foundry Co.

## SPECIFICATIONS

ITEM NUMBER	DESCRIPTION	MATERIAL	QTY.
①	Breakable Stem Coupling	Cast Iron	1
②	Breakable Standpipe Coupling (HALF CIRCLE)	Cast Iron	2
③	Standpipe Coupling Bolt & Nut	Stainless Steel	2
④	Clevis Pin	Stainless Steel	2
⑤	Cotter Pin	Stainless Steel	2
⑥	Standpipe Coupling Seal	Lathe-Cut Buna-N Rubber	1
⑦	Bonnet Seal (NOT SHOWN)	Lathe-Cut Buna-N Rubber	1
⑧	Stem Dampener "O"-Ring (Not Shown)	Buna-N Rubber	1

SIZE: 4½ or 5¼" Main Valve Opening

HRPI Products are engineered and manufactured using the latest computerized technology to ensure quality products with repeatable tolerances.

HRPI Guarantees this product to be compatible, and will operate with the fire hydrant when installed properly. The use of this product shall not affect any published warranties available to the buyer.

PRODUCTS MEET OR EXCEED THE AWWA C502 STANDARD FOR DRY-BARREL FIRE HYDRANTS.

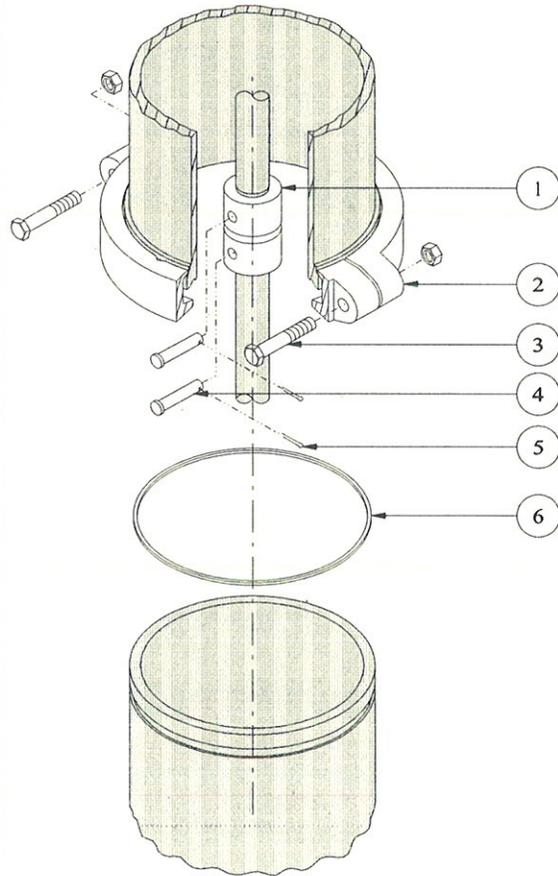

FAX: (918) 224-6857

# Hydrant Repair Parts, Inc.

7900 New Sapulpa Road, Tulsa, OK 74131 • (918) 224-8713

1-800-776-8713 or 1-800-548-9123

U.S. Pipe is a registered trademark of U.S. Pipe & Foundry Co., Birmingham, AL.  
Hydrant Repair Parts, Inc., is not affiliated with U.S. Pipe & Foundry Co.

EXTENSION KIT  AVK MODELS 2700 & 2800  
FOR FIRE HYDRANTS

## SPECIFICATIONS

ITEM NUMBER	DESCRIPTION	MATERIAL	QTY.
1	Standpipe Gasket	Molded "T" Neoprene	2
2	Hydrant Lubricant	FDA Approved Mineral Oil	1
3	Standpipe Extension	Ductile Pipe	1
4	Extension Stem	Steel	1
5	Bolt & Nut	Zinc-Plated Steel	4
6	Standpipe Flange	Ductile Iron	2
7	Extension Stem Coupling	Steel	1
8	Snap Ring	Stainless Steel	2
9	Clevis Pin	Stainless Steel	2
10	Cotter Pin	Stainless Steel	2

SIZE: 5/4" Main Valve Opening

HRPI Products are engineered and manufactured using the latest computerized technology to ensure quality products with repeatable tolerances.

HRPI Guarantees this product to be compatible, and will operate with the fire hydrant when installed properly. The use of this product shall not affect any published warranties available to the buyer.

PRODUCTS MEET OR EXCEED THE AWWA C502 STANDARD FOR DRY-BARREL FIRE HYDRANTS.

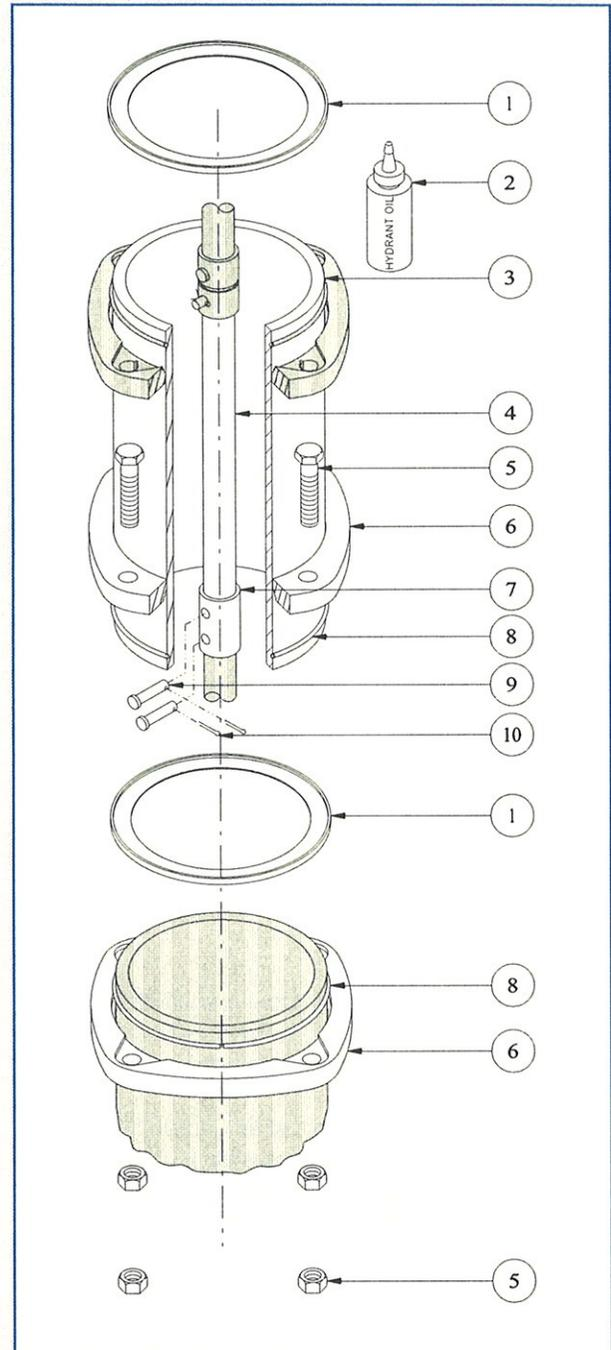

FAX: (918) 224-6857

 **Hydrant Repair Parts, Inc.**  
7900 New Sapulpa Road, Tulsa, OK 74131 • (918) 224-8713  
1-800-776-8713 or 1-800-548-9123

## SPECIFICATIONS

ITEM NUMBER	DESCRIPTION	MATERIAL	QTY.
1	Bolt & Nut	Zinc-Plated Steel	4
2	Breakable Stem Coupling	Steel	1
3	Upper Clevis Pin	Stainless Steel	1
4	Lower Coupling Pin	Stainless Steel	1
5	Cotter Pin	Stainless Steel	3
6	Standpipe Gasket	Molded "T" Neoprene	1
7	Snap Ring	Stainless Steel	1
8	Breakable Safety Flange	Cast Iron	1
9	Hydrant Lubricant	FDA Approved Mineral Oil	1

SIZE: 5 1/4" Main Valve Opening

HRPI Products are engineered and manufactured using the latest computerized technology to ensure quality products with repeatable tolerances.

HRPI Guarantees this product to be compatible, and will operate with the fire hydrant when installed properly. The use of this product shall not affect any published warranties available to the buyer.

PRODUCTS MEET OR EXCEED THE AWWA C502 STANDARD FOR DRY-BARREL FIRE HYDRANTS.

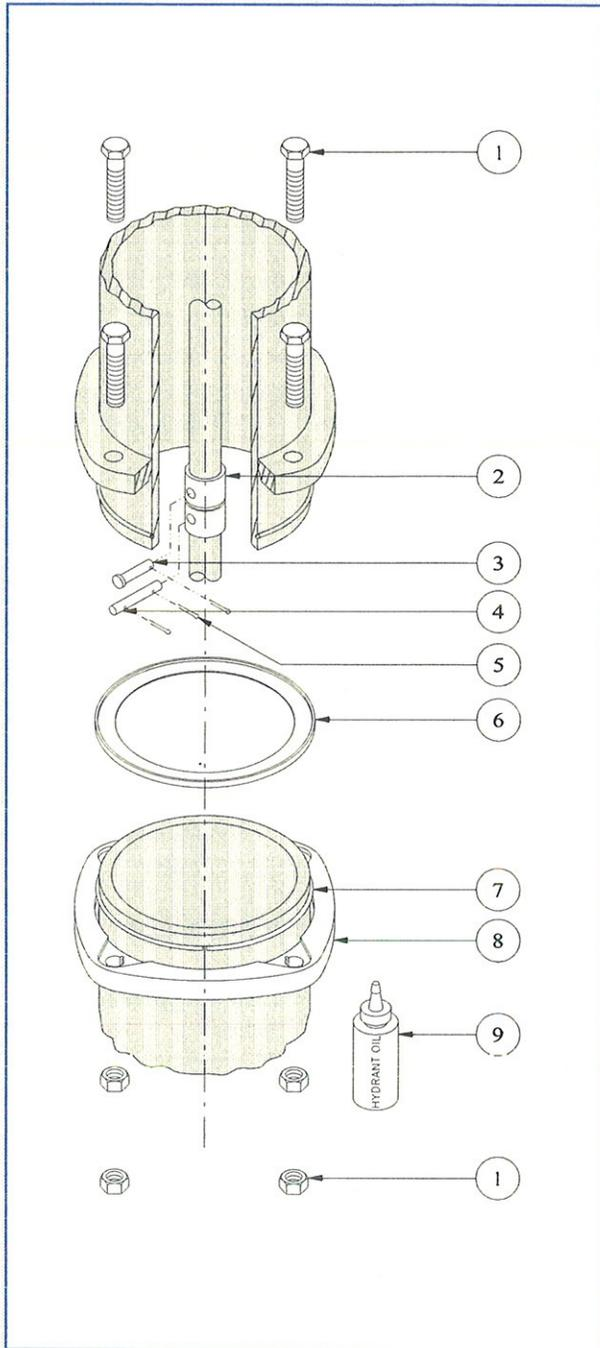

FAX: (918) 224-6857

# Hydrant Repair Parts, Inc.

7900 New Sapulpa Road, Tulsa, OK 74131 • (918) 224-8713

1-800-776-8713 or 1-800-548-9123

AVK is a registered trademark of American AVK Co., Fresno, CA.  
Hydrant Repair Parts, Inc., is not affiliated with American AVK Co.

EXTENSION KIT FOR  EAST JORDAN BR MIDWEST  
FIRE HYDRANTS

## SPECIFICATIONS

ITEM NUMBER	DESCRIPTION	MATERIAL	QTY.
1	Standpipe Gasket	Cloth-Inserted SBR Rubber	2
2	Extension Barrel	Ductile Iron	1
3	Extension Stem	Steel	1
4	Bolt & Nut	Zinc-Plated Steel	8
5	Extension Stem Coupling	Steel	1
6	Cotter Pin	Stainless Steel	2
7	Clevis Pin	Stainless Steel	2

SIZE: 5¼" Main Valve Opening

HRPI Products are engineered and manufactured using the latest computerized technology to ensure quality products with repeatable tolerances.

HRPI Guarantees this product to be compatible, and will operate with the fire hydrant when installed properly. The use of this product shall not affect any published warranties available to the buyer.

PRODUCTS MEET OR EXCEED THE AWWA C502 STANDARD FOR DRY-BARREL FIRE HYDRANTS.

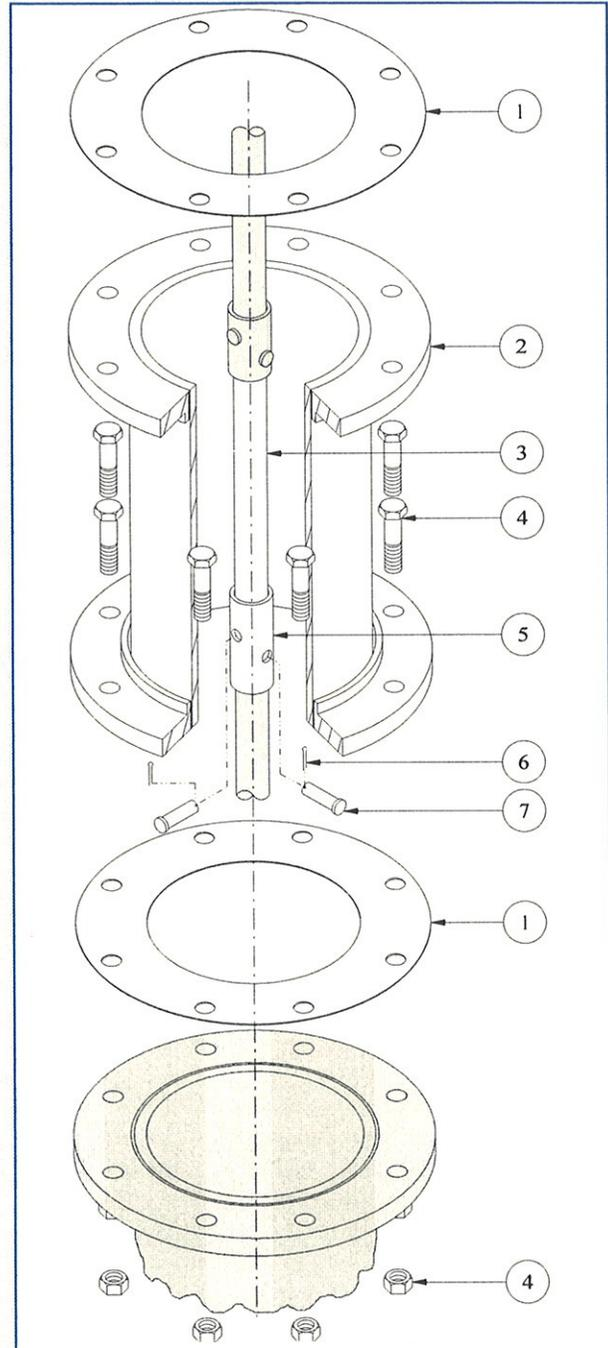

FAX: (918) 224-6857

# Hydrant Repair Parts, Inc.

7900 New Sapulpa Road, Tulsa, OK 74131 • (918) 224-8713

1-800-776-8713 or 1-800-548-9123

East Jordan is a registered trademark of East Jordan Iron Works, Inc., East Jordan, Michigan.  
Hydrant Repair Parts, Inc., is not affiliated with East Jordan Iron Works, Inc.



EXTENSION KITS FOR  PACIFIC STATES MODELS 1 & 2  
FIRE HYDRANTS

## SPECIFICATIONS

ITEM NUMBER	DESCRIPTION	MATERIAL	QTY.
1	Standpipe Gasket	Cloth-Inserted SBR Rubber	2
2	Extension Barrel	Ductile Iron	1
3	Extension Stem	Steel	1
4	Bolt & Nut	Zinc-Plated Steel	8
5	Extension Stem Coupling	Steel	1
6	Coupling Spring Pin	Stainless Steel	2

SIZE: 4" or 5" Main Valve Opening

HRPI Products are engineered and manufactured using the latest computerized technology to ensure quality products with repeatable tolerances.

HRPI Guarantees this product to be compatible, and will operate with the fire hydrant when installed properly. The use of this product shall not affect any published warranties available to the buyer.

PRODUCTS MEET OR EXCEED THE AWWA C502 STANDARD FOR DRY-BARREL FIRE HYDRANTS.

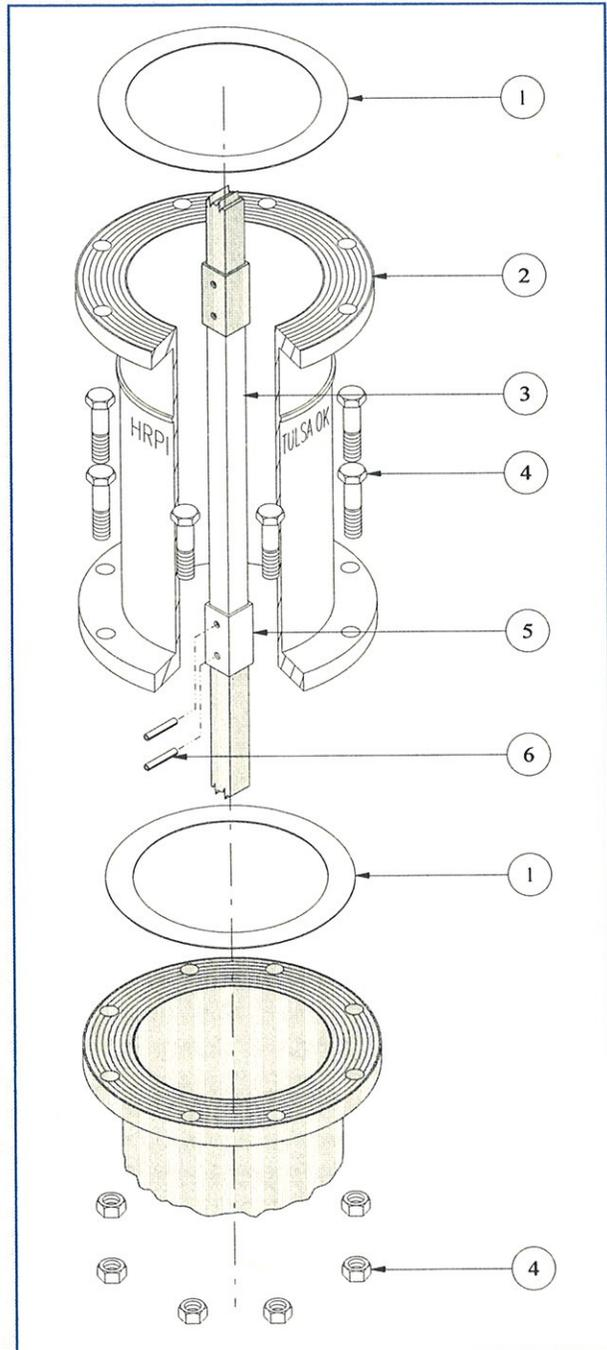

FAX: (918) 224-6857

# Hydrant Repair Parts, Inc.

7900 New Sapulpa Road, Tulsa, OK 74131 • (918) 224-8713

1-800-776-8713 or 1-800-548-9123

Pacific States is a registered trademark of Pacific States Pipe Co., a division of McWane, Inc., Provo, Utah.  
Hydrant Repair Parts, Inc. is not affiliated with Pacific States Pipe Co.

