

EXTENSION KITS FOR  M & H 929  
FIRE HYDRANTS

## SPECIFICATIONS

ITEM NUMBER	DESCRIPTION	MATERIAL	QTY.
1	Extension Barrel	Ductile Iron	1
2	Extension Stem	Steel	1
3	Bolt & Nut	Zinc-Plated Steel	6
4	Extension Stem Coupling	Cast Iron	1
5	Coupling Bolt & Nut	Stainless Steel	2
6	Extension "O"-Ring	Buna-N Rubber	1
7	Extension Lug	Cast Iron	6

SIZE: 4½" and 5¼" Main Valve Opening

HRPI Products are engineered and manufactured using the latest computerized technology to ensure quality products with repeatable tolerances.

HRPI Guarantees this product to be compatible, and will operate with the fire hydrant when installed properly. The use of this product shall not affect any published warranties available to the buyer.

PRODUCTS MEET OR EXCEED THE AWWA C502 STANDARD FOR DRY-BARREL FIRE HYDRANTS.

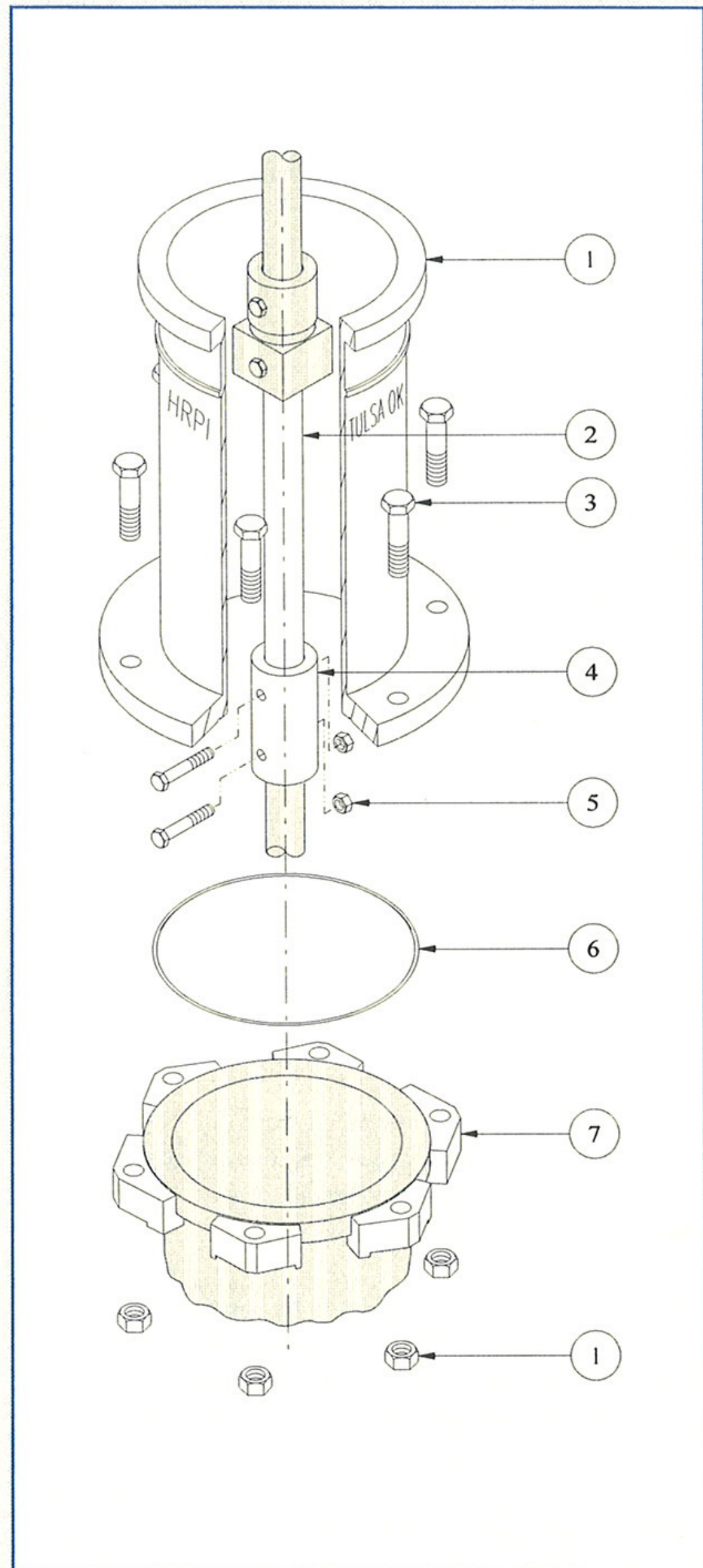

FAX: (918) 224-6857

# Hydrant Repair Parts, Inc.

7900 New Sapulpa Road, Tulsa, OK 74131 • (918) 224-8713

1-800-776-8713 or 1-800-548-9123