

TRAFFIC REPAIR KITS FOR  WATEROUS PACER WB-67 AND TREND WB-77 FIRE HYDRANTS

SPECIFICATIONS

ITEM NUMBER	DESCRIPTION	MATERIAL	QTY.
1	Bolt & Nut	Zinc-Plated Steel	4
2	Breakable Flange	Cast Iron	1
3	Safety Stem Coupling (HALVES)	Steel	2
4	Flange Lock Ring	Stainless Steel	1
5	Coupling Bolt & Nut	Stainless Steel	2*
6	Standpipe Gasket	Molded "L" Neoprene	1
7	Support Gasket (NOT SHOWN)	Lathe-Cut Buna-N Rubber	2**

*Note: Four nuts are included in kit. Two maybe extra.

**Note: Item #7 is not required for the Trend hydrant.

SIZE: 5¼" or 4¾" Main Valve Opening

HRPI Products are engineered and manufactured using the latest computerized technology to ensure quality products with repeatable tolerances.

HRPI Guarantees this product to be compatible, and will operate with the fire hydrant when installed properly. The use of this product shall not affect any published warranties available to the buyer.

PRODUCTS MEET OR EXCEED THE AWWA C502 STANDARD FOR DRY-BARREL FIRE HYDRANTS.

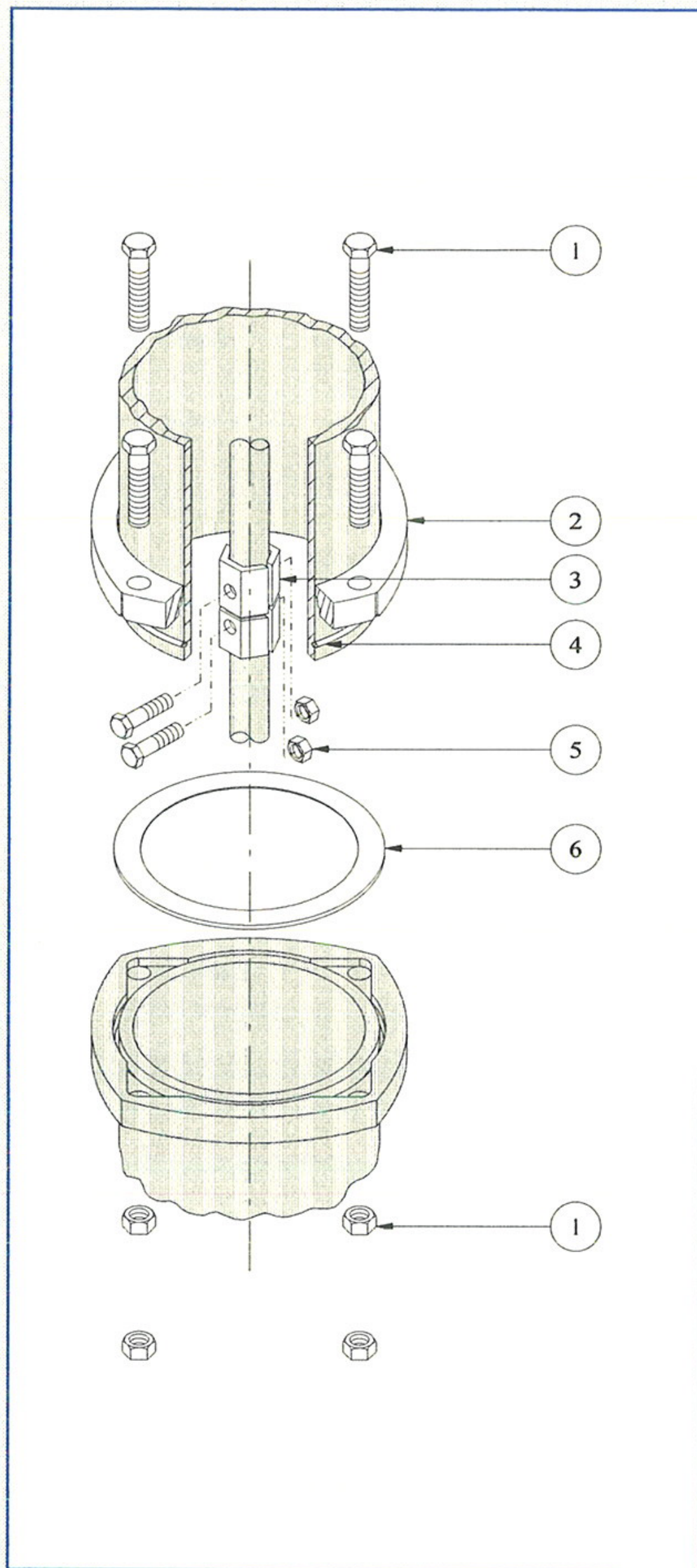

FAX: (918) 224-6857

Hydrant Repair Parts, Inc.

7900 New Sapulpa Road, Tulsa, OK 74131 • (918) 224-8713

1-800-776-8713 or 1-800-548-9123