

EXTENSION KITS FOR  WATEROUS PACER AND TREND FIRE HYDRANTS

SPECIFICATIONS

ITEM NUMBER	DESCRIPTION	MATERIAL	QTY.
1	Standpipe Gasket	Molded "L" Neoprene	2
2	Standpipe Extension	Ductile Pipe	1
3	Flange Lock Ring	Stainless Steel	2
4	Standpipe Extension Flange	Ductile	2
5	Extension Stem	Steel	1
6	Bolt & Nut	Zinc-Plated Steel	4
7	Extension Stem Coupling (HALVES)	Steel	2
8	Coupling Bolt & Nut	Stainless Steel	2
9	Hydrant Lubricant	FDA Approved Mineral Oil	1
10	Support Gasket (NOT SHOWN)	Lathe-Cut Buna-N Rubber	2*

* Note: Item #10 is not required for the Trend hydrant.

SIZE: 5¼" or 4¾" Main Valve Opening

HRPI Products are engineered and manufactured using the latest computerized technology to ensure quality products with repeatable tolerances.

HRPI Guarantees this product to be compatible, and will operate with the fire hydrant when installed properly. The use of this product shall not affect any published warranties available to the buyer.

PRODUCTS MEET OR EXCEED THE AWWA C502 STANDARD FOR DRY-BARREL FIRE HYDRANTS.

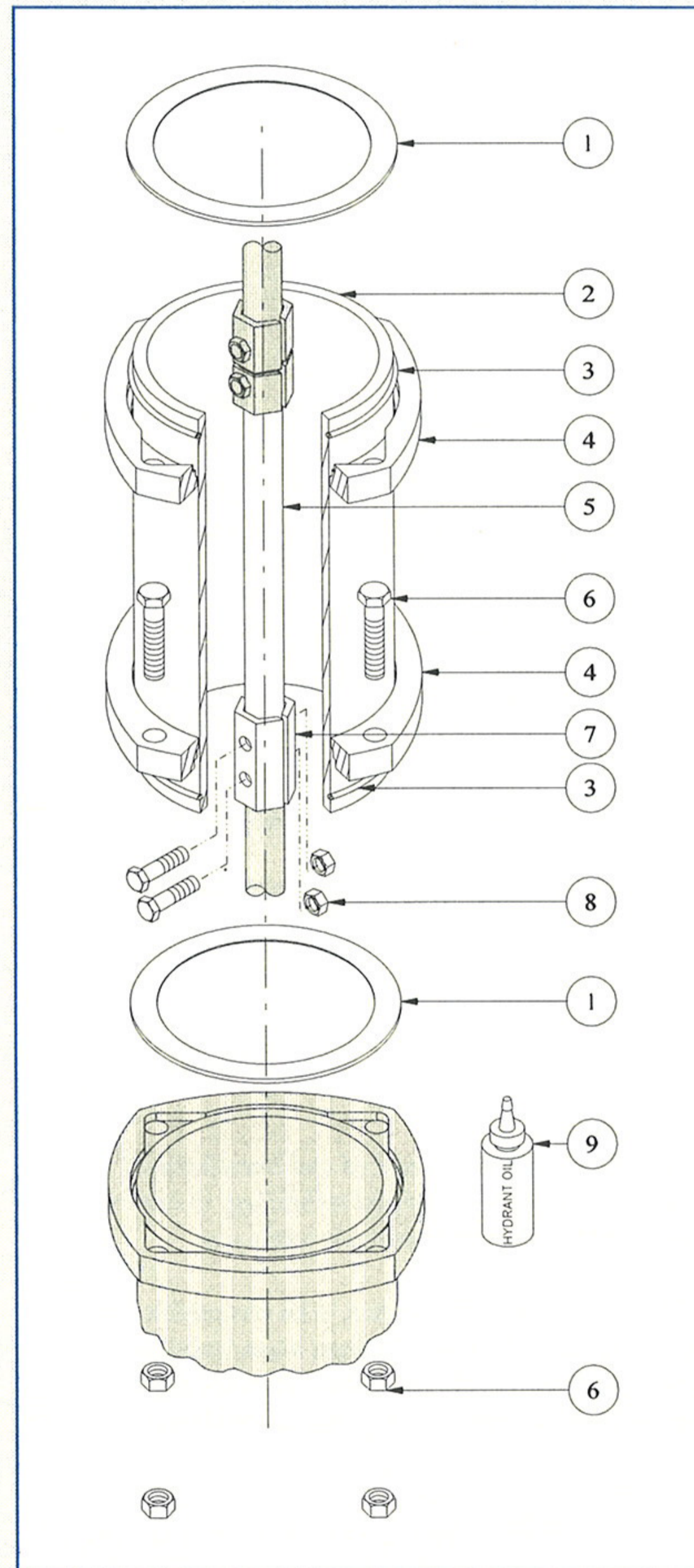

FAX: (918) 224-6857

 **Hydrant Repair Parts, Inc.**
 7900 New Sapulpa Road, Tulsa, OK 74131 • (918) 224-8713
 1-800-776-8713 or 1-800-548-9123