

TenSette Pipet Model 19700-10



General Information

The Hach TenSette™ Pipet is a precision device for dispensing small quantities of liquids. Rugged construction and precision manufacturing ensure prolonged use and dependability with a minimum of service. Ten separate volumes (from 1.0 to 10.0 mL in 1.0-mL increments) can be selected simply by dialing the desired setting. Reproducibility is within 1.5 percent for the 1.0, 2.0, 3.0 and 4.0-mL settings. All other settings will deliver within one percent or better. Nonwettable polyethylene pipet tips ensure quantitative transfer of aqueous solutions.

The TenSette Pipet is factory-set to dispense sample volumes of 1.0, 2.0, 3.0, 4.0, 5.0, 6.0, 7.0, 8.0, 9.0, and 10.0 mL at an altitude of 1000 feet (305 meters) above sea level. It will replace individual pipets used in general laboratory work while eliminating such disadvantages as breakage and washing.

For best results, always use a new tip for each pipetting operation. After being used several times, the pipet tip may retain some liquid, causing an error in delivery. Each pipet is supplied with 50 tips. Order Hach replacements, Cat. No. 21997-96 for best results.

Always use careful and even hand movements for best reproducibility. If the pipet does not operate smoothly, disassemble and coat the piston and retainer with high-quality stopcock grease. The metering turret also may be lightly coated with grease.

For best accuracy, both the room temperature and the solution being pipetted should be between 20 and 25°C. Avoid palming the pipet an unnecessarily long time prior to use because the aliquot volume could be affected by elevated temperatures.

Never lay the pipet down with liquid in the tip. Solution could leak into the pipet and cause corrosion.

Operating Instructions

1. Attach a clean tip. Holding the TenSette in one hand, gently press the tip onto the tapered nose of the pipet until the tip is held firmly and a good seal is obtained.

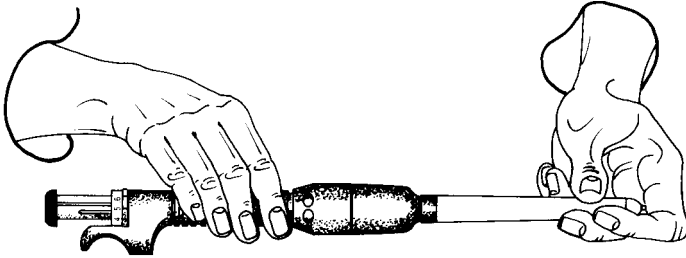

2. Turn the turret cap to align the desired volume on the volume-setting ring with the mark on the housing assembly.

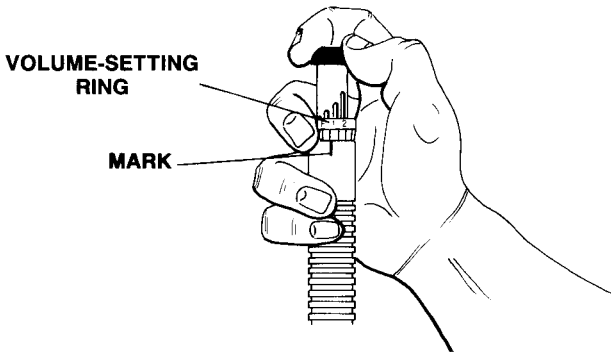

3. Press down on the turret cap with the thumb, using a smooth motion, until the turret reaches the stop. Immerse the tip about 5 mm ($\frac{1}{4}$ ") below the surface of the solution to avoid drawing air into the tip. Do not insert the tip any deeper, or the delivery volume may be affected.

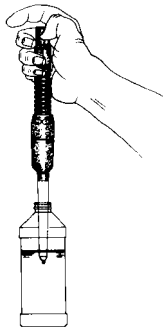

4. While maintaining a light constant pressure, allow the turret to return to the extended position very slowly. Do not let the turret snap into place, or the delivery volume will be affected.

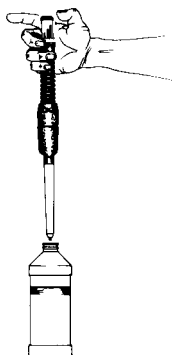

5. With the turret up, withdraw the tip from the liquid and move it to the receiving vessel. Avoid placing pressure on the cap while moving the pipet.

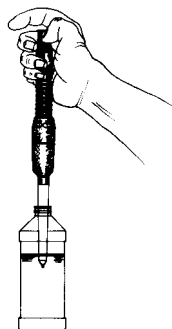

6. Use the thumb and forefinger to twist the turret cap to the next higher position on the volume-setting ring to assure full blowout and quantitative transfer of the sample. The "F" position provides full blowout for the 1.0-mL setting.

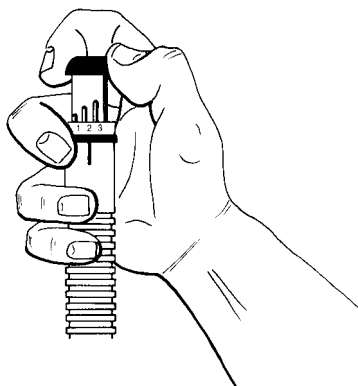

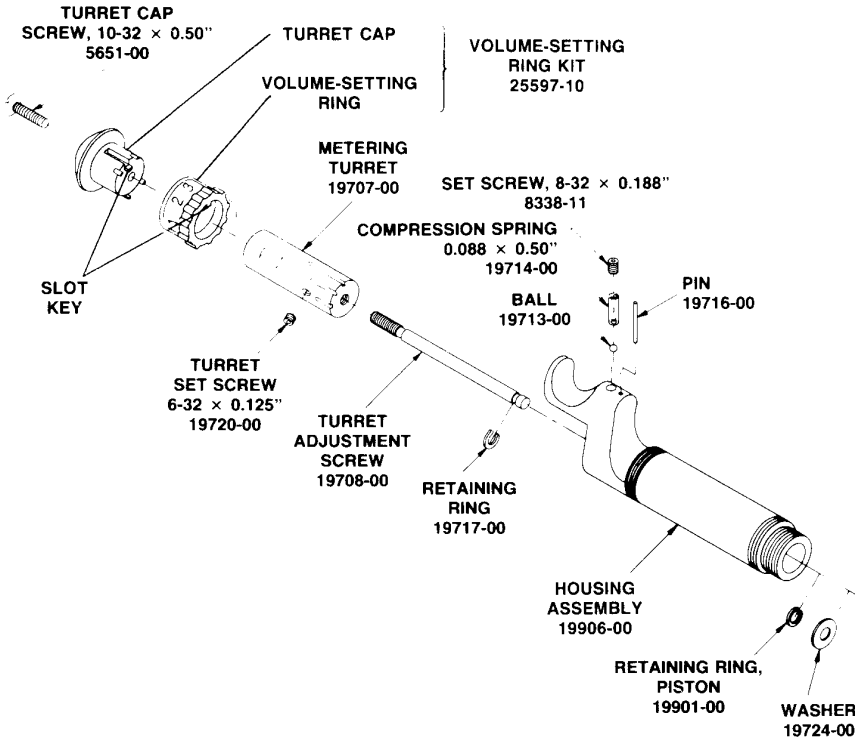
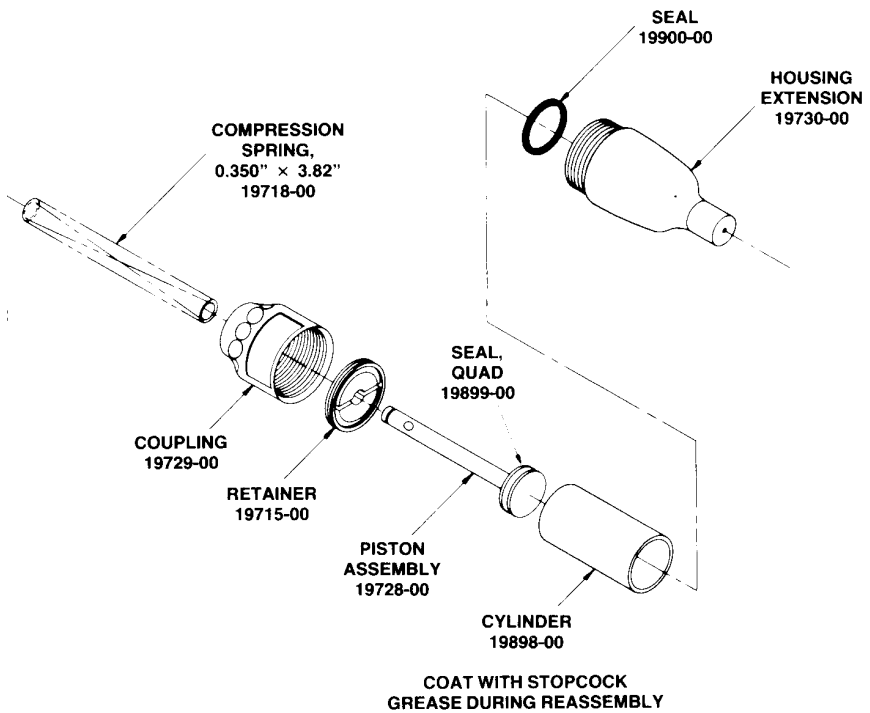

Figure 1 TenSette Pipet, Exploded View



7. With the tip in contact with the side of the receiving vessel, slowly and smoothly press down on the cap until the turret reaches the stop and the solution is completely discharged.



Maintenance

Periodically disassemble the lower body. Clean and lubricate the piston and retainer to ensure smooth operation. *See Figure 1.* Use a high quality stopcock grease.

If the TenSette Pipet is to be used at an altitude significantly different than 1000 feet (305 meters) above sea level, the delivery volume will be affected. *See Figure 2.* The instrument can be reset for greater accuracy as follows:

1. Remove the turret cap screw, turret cap and volume-setting ring. Loosen the turret set screw by one or two turns.
2. Place a narrow-necked vessel (for example, a 25-mL volumetric flask) on an analytical balance and zero the balance (or record the weight if the balance is non zeroing).
3. Weigh the quantity of water dispensed at the 1.0-mL setting. Use only high-quality demineralized water at 20-25°C.
4. If the weight of the water is other than 1.00 g, use a small screwdriver to give the turret adjustment screw (inside the metering turret) a slight turn. Turn clockwise to increase delivery volume.
5. Zero the balance (or record the weight) just prior to adding another 1.0 mL of demineralized water. If the added weight is other than 1.0 g, repeat Steps 3 through 5.

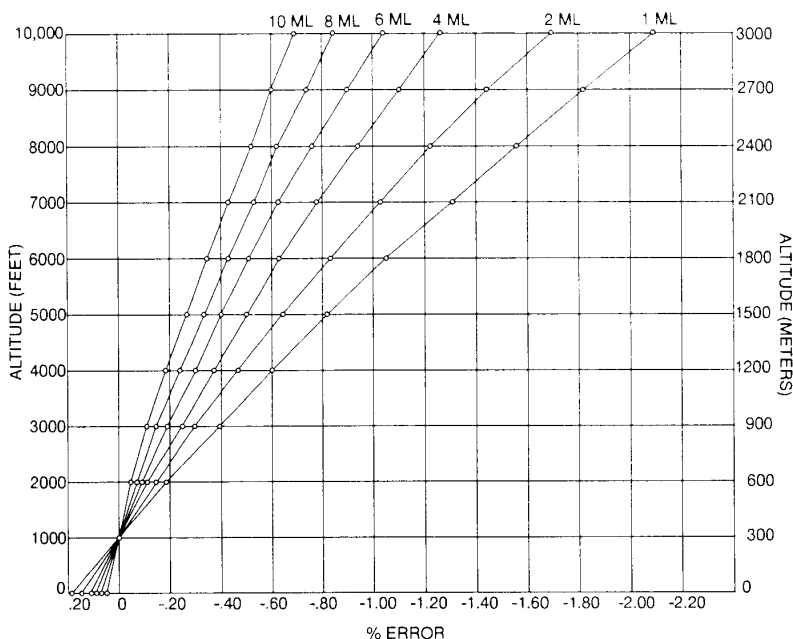

Figure 2 **Effect of Altitude on Delivery**

6. When the weight of the water delivered at the 1-mL setting is 1.0 g, set the turret for a delivery of 10.0 mL.
7. Zero the balance (or record the weight) just prior to adding 10.0 mL of water. If the weight is other than 10.0 g, adjust the delivery volume as described in Step 4. When the pipet delivers 10.00 g at the 10.0-mL setting, check the 1-mL setting again.
8. When the delivery volume is accurate for both the 1.00-mL and the 10.0-mL settings, tighten the set screw until flush with the surface of the housing assembly. Replace the volume-setting ring, turret cap and turret cap screw.

Warranty

The Hach TenSette Pipet has been carefully engineered and constructed for years of accurate, dependable service. It is fully guaranteed for one year.

REPAIR SERVICE

Authorization must be obtained from Hach Company before sending any items for repair. Please contact the Hach Factory Service Center serving your location.

In the United States:

Hach Company

100 Dayton Ave.

P.O. Box 907

Ames, Iowa 50010

800-227-4224 (U.S.A. only)

FAX: (515) 232-1276

Telephone: (515)-232-2533

In Canada:

Hach Sales & Service Canada Ltd.

1313 Border Street, Unit 34

Winnipeg, Manitoba

R3H 0X4

800-665-7635

(204) 632-5598

FAX: (204) 694-5134

All other locations:

Hach Company, World Headquarters

P.O. Box 389

Loveland, Colorado, 80539 U.S.A

Telephone (303) 669-3050

FAX (303) 669-2932

TenSette Pipet Replacement Parts

Cat. No.	Description	Unit
19713-00	Ball, 0.125"	each
19718-00	Compression Spring, 0.350 × 3.82"	each
19714-00	Compression Spring, 0.088 × 0.50"	each
19729-00	Coupling	each
19898-00	Cylinder, glass	each
19906-00	Housing Assembly	each
19730-00	Housing Extension	each
19700-08	Instruction Manual	each
19727-00	Metering Turret	each
19716-00	Pin, 0.062 × 0.75"	each
21997-96	Pipet Tips, pkg of 50	each
19728-00	Piston Assembly	each
19715-00	Retainer	each
19717-00	Retaining Ring, turret adjusting screw	each
19901-00	Retaining Ring, piston	each
5651-00	Screw, turret, 10-32 × 0.50"	each
19720-00	Set Screw, turret, 6-32 × 0.125"	each
8338-11	Set Screw, 8-32 × 0.188"	each
19900-00	Seal	each
19899-00	Seal, quad	each
562-75	Stopcock Grease, 75 g	each
19708-00	Turret Adjustment Screw	each
25597-10	Turret Cap and Volume-Setting Ring Assembly	each
19724-00	Washer, flat	each



HACH COMPANY
WORLD HEADQUARTERS
P.O. Box 389
Loveland, Colorado 80539-0389
Telephone: (970) 669-3050
FAX: (970) 669-2932

FOR TECHNICAL ASSISTANCE, PRICE INFORMATION AND ORDERING:

In the U.S.A. - **Call toll-free 800-227-4224**

Outside the U.S.A. - **Contact the HACH office or distributor serving you.**

On the Worldwide Web - **www.hach.com**; E-mail - **techhelp@hach.com**
