

PERFORMANCE

°F %RH	80 60	75 50
Water Removal (P/Day)	70	43
Efficiency (P/kWh)	5.0	3.3
Energy Factor (L/kWh)	2.4	1.6

ELECTRICAL

°F %RH	80 60
Supply Voltage	110-120V
Current Draw	5.1A
MCA*	7.7A
MOP*	15A
Maximum Breaker Size	15A
Power	580W
Power Cord	110-120V
CFM	150 @ 0.0"
BTU (Total)	5,000
BTU (Heat of Condensation)	3,000
BTU (Motor Load)	2,000

SPECS

Control Type	Onboard
Refrigerant Type	R410a
Refrigerant Amount	15 oz
Weight	55 lb
Air Filter MERV Rating	MERV-13
Dimensions	9" x 12" x 1"
Drain Port Connection	3/4" Threaded NPT
Operating Temperature	56 F Min - 100 F Max



DIMENSIONS

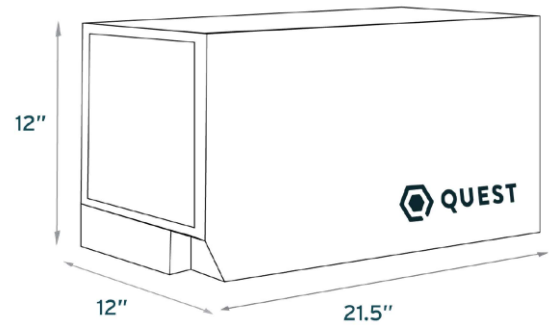

FEATURES

- + The most compact Quest unit for mobility and small space designs
- + Superior Filtration: Compatible with MERV-13 filters for cleaner, healthier air, capturing particulates such as mold, pollen, and some viruses
- + Installation for overhead or ground placement
- + Auto-restart in the event of power outage
- + Onboard dehumidistat and low voltage terminal block for optional external controls

Specifications are subject to change without notice. Drawings are not to scale. *See manual for details on MCA/MOP.