

PERFORMANCE

°F %RH	80 60	75 50
Water Removal (P/Day)	506	349
Efficiency (P/kWh)	8.1	6.2
Energy Factor (L/kWh)	3.8	2.9

ELECTRICAL

°F %RH	80 60	
Supply Voltage	277V	
Current Draw	10.0A	
MCA*	16.3A	
MOP*	25A	
Recommended Breaker Size	20A	
Power	2,700W	
Power Cord	NEMA L7-20P	
CFM	1,350	
BTU (Total)	31,900	
BTU (Heat of Condensation)	23,000	
BTU (Motor Load)	8,900	

SPECS

Control Type	External control required (not provided)
Refrigerant Type	R410a
Refrigerant Amount	4 lb 8 oz
Weight	280 lb
Air Filter MERV Rating	MERV-13
Dimensions	18" x 20" x 2"
Drain Port Connection	3/4" Threaded NPT
Operating Temperature	56 F Min-95 F Max



DIMENSIONS

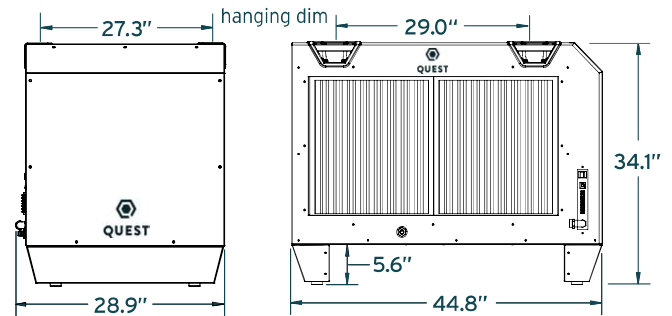

FEATURES

- + **Patented M-CoRR Technology:** Multi-coil design achieves highest efficiency available in its class
- + **Superior MERV-13 filtration:** Removes more harmful contaminants from the air, such as mold, bacteria and some viruses
- + **Integrated Hang Points** and handles allows for easy movement and flexible installation
- + **Low Amp Draw**, freeing up electricity for other equipment
- + **Auto-Restart** to previous settings after loss of power

Specifications are subject to change without notice. Drawings are not to scale. *See manual for details on MCA/MOP.