

INDIAN SPRINGS TANK-CAR KIT

INDIAN SPRINGS ERK

Edition 1 Rev 3
October 2019



1. INTRODUCTION

Leaks in tank cars, cargo tanks and portable tanks rarely occur. When they do occur, however, prompt corrective action is required by trained competent personnel with special equipment. The ERK and this instruction booklet are made in the belief that they will be helpful in handling such emergencies.

1.1 DISCLAIMER

The information in this booklet is drawn from sources believed to be reliable. The manufacturer makes no guarantee, and assume no liability, in connection with any of this information. Moreover, it should not be assumed that every acceptable procedure is included, or that special circumstances may not warrant modified or additional procedures. The user should be aware that changing technology or regulations may require changes in the recommendations contained herein. Appropriate steps should be taken to ensure that the information is current when used. These recommendations should not be confused with federal, state, provincial, municipal, or insurance requirements, or with national safety codes.

1.2 GENERAL DESCRIPTION

The ERK is designed for use with the standard tank cars, cargo tanks, and portable tanks. These tanks vary in capacity. The kit is not designed to be used on liquid-full tank cars or cargo tanks.

1.3 TRAINING AND SAFETY

Emergency Response and other personnel must be properly trained in the use of the devices and tools within the Emergency Kit ERK. Training must include the use of respiratory equipment and all other safety equipment. Knowledge of the properties of the leaking product is essential.

1.4 PERSONAL PROTECTIG EQUIPMENT

Personnel safety is of primary importance. Emergency response should only be performed by authorized personnel who are trained in the procedures and are equipped with suitable respiratory and personal protective equipment. The type of respiratory equipment required will be determined by the severity of the leak and the potential for exposure to the product in question. Please refer to the product SDS, HazMat Guide and other resources for proper personal protection requirements.

1.5 LEAK DETECTION

As soon as there is an indication of the presence of the hazard in the air, authorized, trained personnel equipped with suitable personal protective equipment should investigate promptly. All other persons should be kept away from the affected area. Efforts to detect the source of any leak should be carried out with an awareness of the potential hazards and use of necessary personal protective equipment.

1.6 ASSISTANCE

Hazmat emergencies should be handled only by trained personnel. If assistance is required, promptly notify your supplier. If the supplier cannot be reached or respond immediately, then

summon help by calling CHEMTREC® in the U.S. 1- 800-424-9300 or CANUTEC in Canada 1-613-996-6666.

1.7 REPORTING REQUIREMENTS

Users should be aware of and comply with Federal, State and local requirements for the reporting of chlorine releases.

1.8 DRAWINGS

The illustrations used in this booklet are used for representation purposes only. Individual tank arrangements may or may not look the same.

2. HOOD SELECTION AND YOKE ASSEMBLY

20A

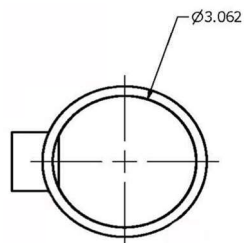
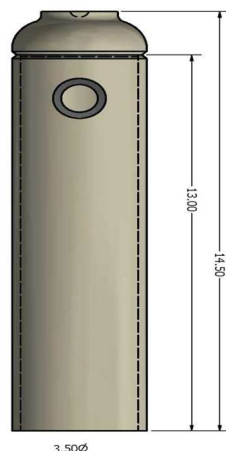

- Thermowell
- Sampling Valve
- Gaskets:
20BMV – Viton
20BEP - EPDM

30A

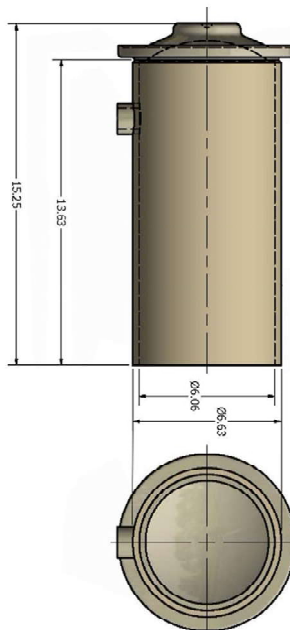

- Gauging Device
- Chlorine 1" Angle Valve
- Gaskets:
30BMV – Viton
30BEP- EPDM

Note: Valve handwheel may have to be removed from chlorine valve for Hood to fit over.

46A

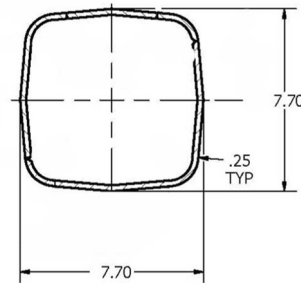
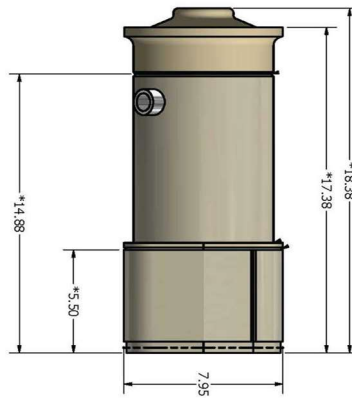

- **Pressure Relief Device Chlorine**
- **Gaskets:**
46BMV – Viton
46BEP - EPDM

54A

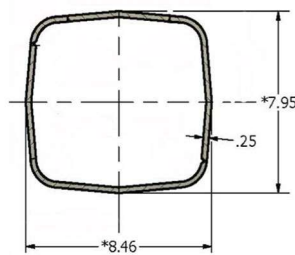
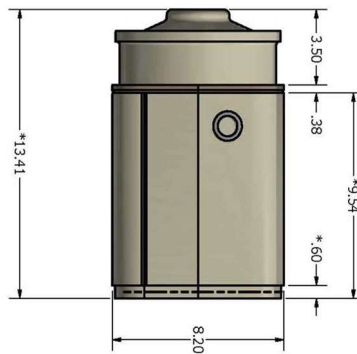

- **Pressure Relief Device Ammonia/LPG**
- **Gaskets:**
54BMV – Viton
54BEP - EPDM

4A

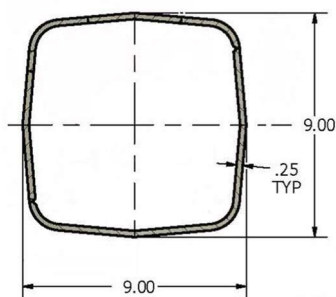
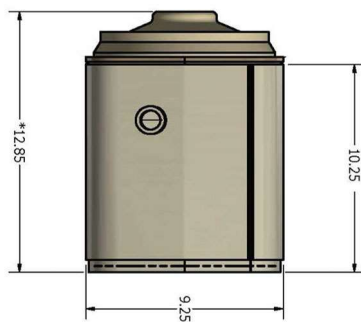

- Pressure Relief Device
- Gaskets:
64BMV – Viton
64BEP - EPDM

YOKE ASSEMBLY 18C

ADJUSTABLE END

FIXED END

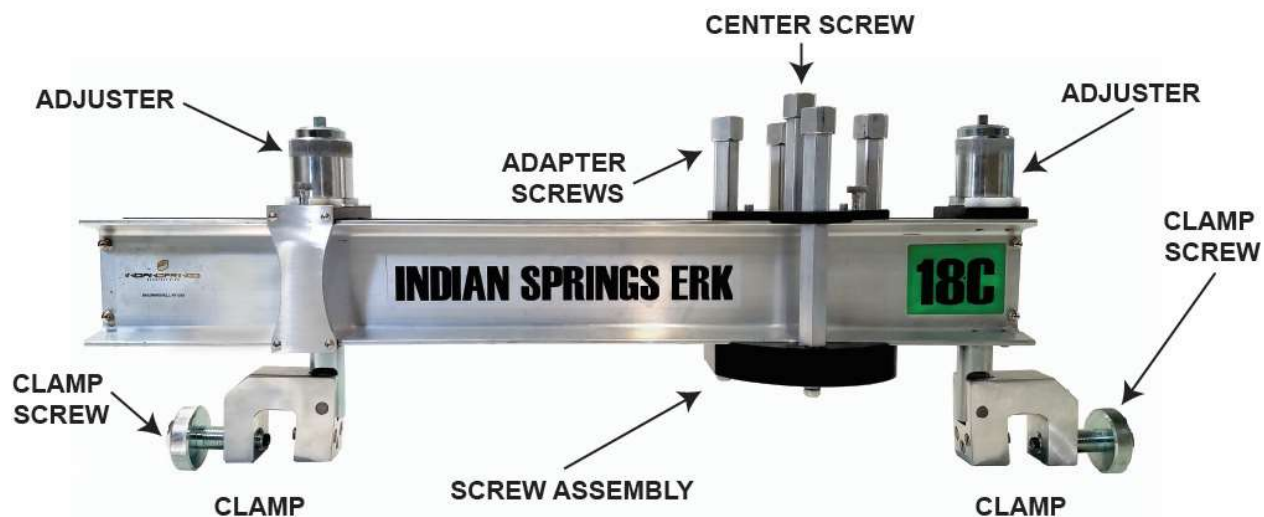

3. DEVICE APPLICATION



3.1

Select appropriate Hood, based upon valve or device to contain (see Section 2).

3.2

Remove Outlet Cap, open Valve on Hood with **WRENCH 200-X**.

3.3

Place appropriate Gasket (Viton or EPDM) on Hood.



3.4

Clean sealing surface with **PAINT SCRAPER X-6** and **WIRE BRUSH X-3**.

**3.5**

Place Hood (with Valve in open position and outlet cap off) with Gasket over leaking device.

NOTE: CERTAIN VALVE MODELS AND DEVICES MAY REQUIRE REMOVAL OF OUTLET PLUGS, HANDWHEELS, LEVERS, OUTLET FACES, ETC. FOR HOOD TO FIT OVER VALVE/DEVICE.

**3.6**

Place **YOKE ASSEMBLY 18C** Clamp (Fixed End) onto tank car housing opposite of leaking device. Rest Clamp (Adjustable End) on housing away from leaking device and Hood.



3.7

Hand tighten Clamp (Fixed End) Screw, tighten further one half-full turn with **WRENCH 200-X**. Note: Wrench X-4 is also available for extra torque.

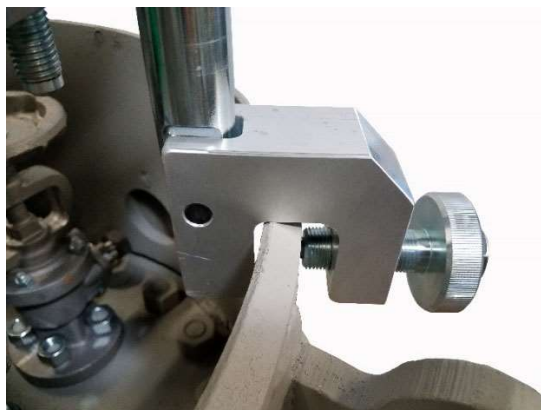
**3.8**

Slide Clamp (Adjusting End) along housing into position to allow **YOKE ASSEMBLY 18C** to bisect Hood.

NOTE: YOKE ASSEMBLY CAN BE ATTACHED UPON THE HOUSING AT ANY TWO POINTS, BUT MOST PREFERABLY ACROSS LARGEST DIAMETER OF HOUSING, IF POSSIBLE, BUT NOT NECESSARY.

**3.9**

Lower or raise unit as needed to slide Screw Assembly over Hood by tightening/loosening Adjusting Caps on either end of **YOKE ASSEMBLY 18C** until Screw Assembly is over hood and unit is level. Box end of **WRENCH 200-X** can be used on Adjusting Caps.

NOTE: Turn adjusters clockwise to lower and counterclockwise to raise. Keep bar level by turning adjusters equally.



3.10

Tighten Center Screw hand tight against Hood. Alternately tighten remaining four Adapter Bolts using **WRENCH 200-X** until leak stops underneath Gasket. Keep Center Screw hand tight.

**3.11**

Close Hood Vent Valve with **WRENCH 200-X**.



3.12
test for leaks.



YOKE ASSEMBLY 18C

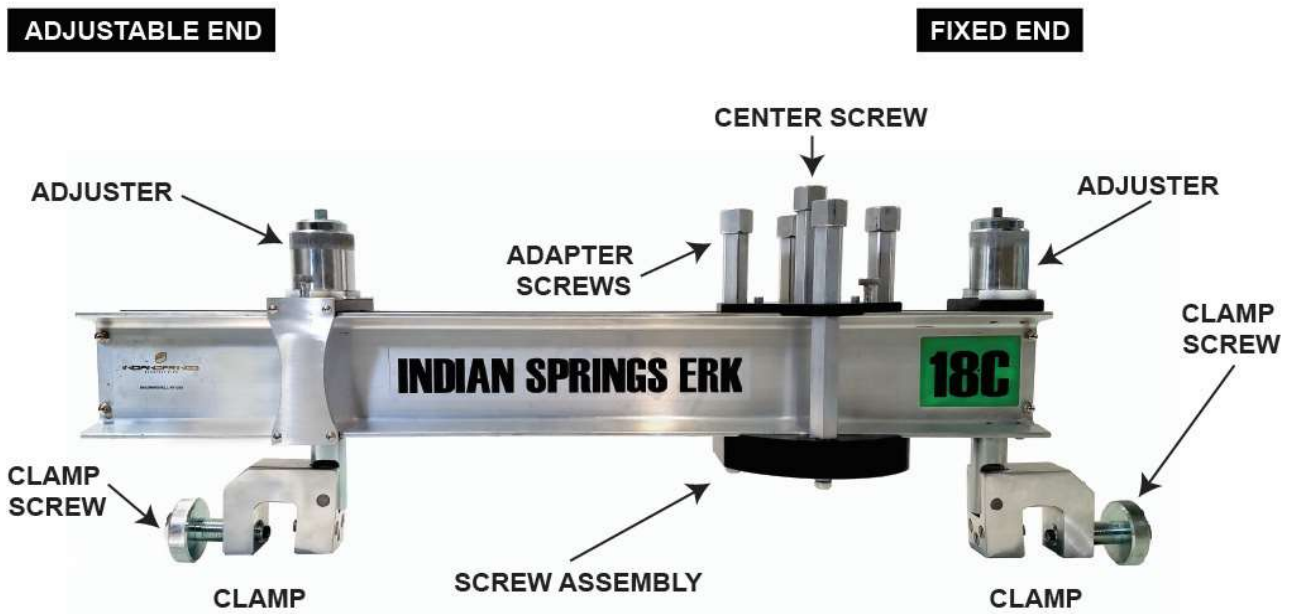

4. APPLICATIONS

DEVICE 20 – Misc. Housing - Sampling Valve / Thermowell



DEVICE 30 – Chlorine Housing / Product Valve



DEVICE 46 – Chlorine Housing / Pressure Relief Device**DEVICE 54 – Misc. Housing - Large Product Valve / Pressure Relief Device**

5. PARTS LIST

Part#	Description	Qty/Kit
18C	Yoke Assembly, Adjusting with Clamping Jaws (38" Max Opening)	1
20A	Hood Assembly with Vent Valve (20V), 3-1/16" ID x 13" Inside Height	1
20BEP	Gasket Molded, EPDM	2
20BMV	Gasket Molded, Viton	2
30A	Hood Assembly with Vent Valve (30V), 5-1/2" ID x 12" Inside Height	1
30BEP	Gasket Molded, EPDM	2
30BMV	Gasket Molded, Viton	2
46A	Hood Assembly with Vent Valve (46V), Base: 6-3/4" sq. x 14.88"H	1
46BEP	Gasket, Molded EPDM	2
46BMV	Gasket, Molded Viton	2
54A	Hood Assembly with Vent Valve (54V), 7-1/2" x 6-7/8" x 9-1/2"H	1
54BEP	Gasket, Molded EPDM	2
54BMV	Gasket, Molded Viton	2
64A	Hood Assembly with Vent Valve (64V), 7-7/8" sq x 10-1/4"H	1
64BEP	Gasket, Molded EPDM	2
64BMV	Gasket, Molded Viton	2
X-1	Rope and Carabiners	1
X-2	Socket Wrench Set	1
X-3	Wire Brush	1
X-4	Wrench, Adjustable, 15"	1
X-5	Hammer, Machinist, 24oz	1
X-6	Paint Scraper, 1-1/4" blade	1
X-7	Kit Box Seals (15 pcs/pkg)	1
X-8	Bolt Cutter	1
X-9	Wire Cutter	1
X-10	Gasket Sack	1
X-11	Tool Bucket and Carabiner	1
X-16	Gripper, Replacement Pkg. (10 pcs. Gripper X-16F, 2 pcs. Gripper X-16S)	1
151-X	Kit Box: 17"H x 19"W x 44"L	1
200-X	Wrench, Valve, 1-1/4" Open End x 3/8" Sq. Box End	1
IX	Instruction Booklet	2



APPENDIX A
LIFTING DEVICES



Rope X-1 and Bucket X-11

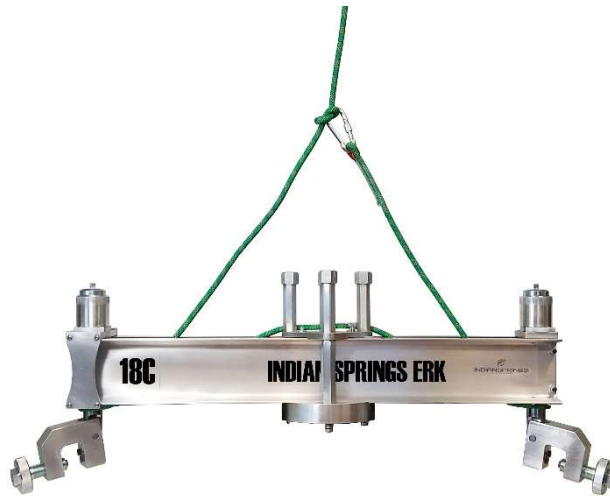

APPENDIX B
GRIPPER REPLACEMENT

Yoke Assembly 28C contains custom made "Grippers" installed in each CLAMPING JAW (Fixed Grippers and Screw Gripper). All grippers should be replaced after each use. Kit contains a Gripper Replacement Pkg. #X-16.

Each Jaw Contains:

A. Fixed Grippers (5 pcs)

B. Screw Gripper (1 pc)



Fixed Grippers: X-16F	Screw Gripper: X-16S
	
<ul style="list-style-type: none"> • Remove screws from the backside of jaw. • Remove grippers. • Insert new grippers in hole. • Re-insert gripper screws. 	<ul style="list-style-type: none"> • Remove screw from the backside of jaw screw holding gripper. • Remove gripper. Insert new gripper in hole. • Re-insert gripper screw, tighten and then loosen one half turn so that gripper rotates freely.