



# Model 475DA/475DAV

## Reduced Pressure Detector Assembly

### Application

Designed for installation on water lines in fire protection systems to protect against both backsiphonage and backpressure of contaminated water into the potable water supply. The Model 475DA/475DAV shall provide protection where a potential health hazard exists. Incorporates metered by-pass to detect leaks and unauthorized water use.

### Standards Compliance

- ASSE® Listed 1047 (4" thru 8")
- AWWA Compliant C550
- UL® Classified (4" thru 10")
- C-UL® Classified (4" thru 10")
- FM® Approved (4" thru 8")
- NYC MEA 170-02-M VOL 2 (4" thru 8")
- Approved by the Foundation for Cross Connection Control and Hydraulic Research at the University of Southern California (4" thru 8")
- Meets the requirements of NSF/ANSI/CAN 61\*  
\*(0.25% MAX. WEIGHTED AVERAGE LEAD CONTENT)

### Materials

Main valve body	Ductile Iron ASTM A 536 Grade 4
Access covers	Ductile Iron ASTM A 536 Grade 4
Coatings	FDA Approved fusion epoxy finish
Fasteners	Stainless Steel, 300 Series
Elastomers	EPDM (FDA approved) Buna Nitrile (FDA approved)
Polymers	NORYL™
Springs	Stainless Steel, 300 series

### Features

Sizes: 4", 6", 8", 10"	
Maximum working water pressure	175 PSI
Maximum working water temperature	140°F
Hydrostatic test pressure	350 PSI
End connections	
(Grooved for steel pipe)	AWWA C606
(Flanged)	ANSI B16.42 Class 150

Relief Valve discharge port:  
2 1/2" - 6" - 2.75 sq. in.  
8" - 10" - 3.69 sq. in.

### Dimensions & Weights (do not include pkg.)

MODELS 475DA & 475DAV SIZE	WEIGHT									
	LESS SHUTOFF VALVES		WITH OS&Y GATES (GXF)		WITH OS&Y GATES (GXG)		WITH BFLY VALVES (GXF)		WITH BFLY VALVES (GXG)	
	lbs.	kg	lbs.	kg	lbs.	kg	lbs.	kg	lbs.	kg
4"	113	51	303	137	279	127	183	83	161	73
6"	187	85	487	221	465	211	291	132	261	118
8"	421	191	897	407	843	382	611	277	565	256
10"	439	199	1113	505	1055	479	713	323	655	297

MODELS 475DA & 475DAV SIZE	DIMENSIONS (approximate)															
	A		B WITH GATE VALVES		B WITH BFLY VALVES		B LESS GATE VALVES		C OS&Y OPEN		C OS&Y CLOSED		C WITH BFLY VALVES		D	
	in.	mm	in.	mm	in.	mm	in.	mm	in.	mm	in.	mm	in.	mm	in.	mm
4" 475DA	18 5/16	465	30	762	27 3/4	705	21	533	22 3/4	578	18 1/4	464	9	229	8	203
4" 475DAV	18 7/8	479	36 1/2	927	32	813	18 1/2	470	22 3/4	578	18 1/4	464	9	229	8	203
6" 475DA	18 11/16	475	35 1/2	902	32 1/8	816	25	635	30 1/8	765	23 3/4	603	10 1/4	260	10	254
6" 475DAV	21	533	42	1067	35 1/4	895	21	533	30 1/8	765	23 3/4	603	10 1/4	260	10	254
8" 475DA	29	737	46	1168	42 9/16	1081	34 7/16	875	37 3/4	959	29 1/4	743	12	305	13	330
8" 475DAV	30 5/16	770	53 1/2	1359	46 9/16	1183	30 5/16	770	37 3/4	959	29 1/4	743	12	305	13	330
10" 475DA	29	737	47 1/2	1207	44 7/16	1129	34 7/16	875	45 3/4	1162	35 3/8	899	13	330	13	330
10" 475DAV	30 5/16	770	56 1/2	1435	50 5/16	1278	30 5/16	770	45 3/4	1162	35 3/8	899	13	330	13	330



MODEL 475DAV



LEAD FREE



NSF/ANSI/CAN 61



MODEL 475DA

### Options

(Suffixes can be combined)

- with OS & Y gate valves (standard)
- L - less shut-off valves (grooved body connections)
- LM - less water meter
- with gpm meter (standard)
- CFM - with cu ft/min meter
- V - vertical flow up configuration
- G - with groove end gate valves
- FG - with flanged inlet gate connection and grooved outlet gate connection
- BG - with grooved end butterfly valves with integral supervisory switches
- BF - with flanged end butterfly valves with integral supervisory switches
- PI - with post indicator gate valve

### Accessories

- Air gap (see spec sheet BF-AG)
- Repair kit (rubber only)
- Thermal expansion tank (Model XT)
- Valve setter (Model FLS or MJS or MJFS)
- Gate valve tamper switch (OSY-40)
- QT-SET Quick Test Fitting Set

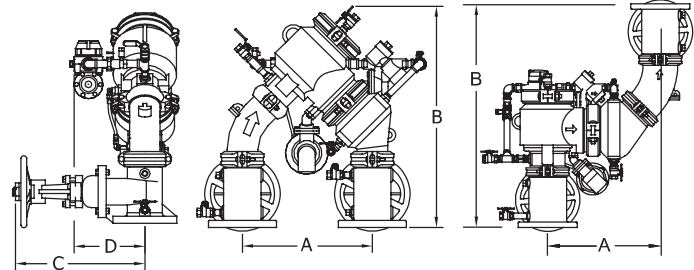

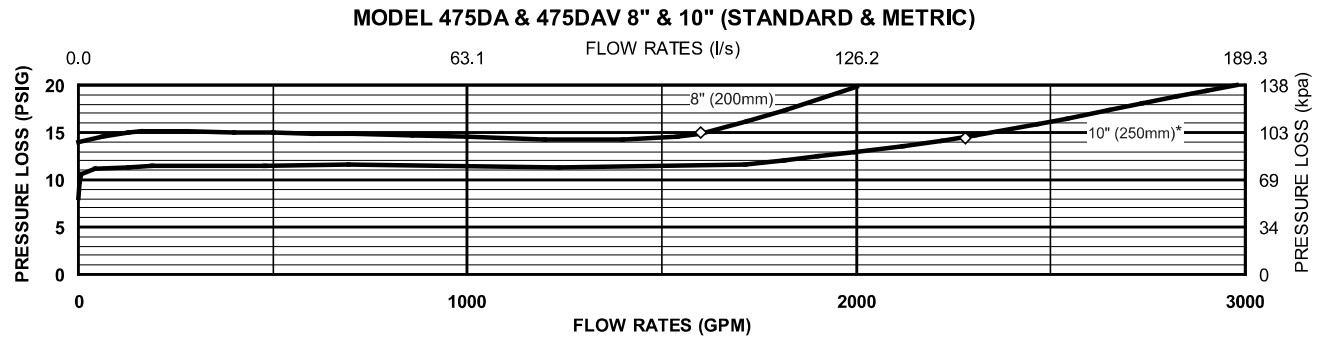
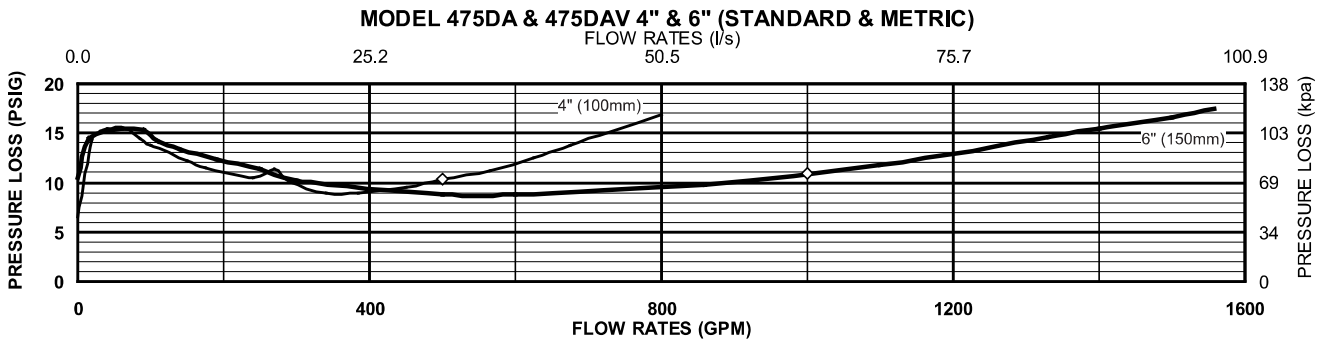

**Typical Installation**

Local codes shall govern installation requirements. To be installed in accordance with the manufacturers' instructions and the latest edition of the Uniform Plumbing Code. Unless otherwise specified, the assembly shall be mounted above adequate drains with sufficient side clearance for testing and maintenance. The installation shall be made so that no part of the unit can be submerged.

Capacity thru Schedule 40 Pipe (GPM)				
Pipe size	5 ft/sec	7.5 ft/sec	10 ft/sec	15 ft/sec
2 1/2"	75	112	149	224
3"	115	173	230	346
4"	198	298	397	595
6"	450	675	900	1351
8"	780	1169	1559	2339
10"	1229	1843	2458	3687

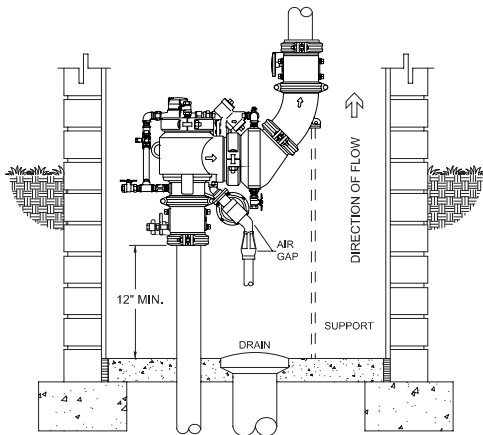

**VERTICAL INSTALLATION**

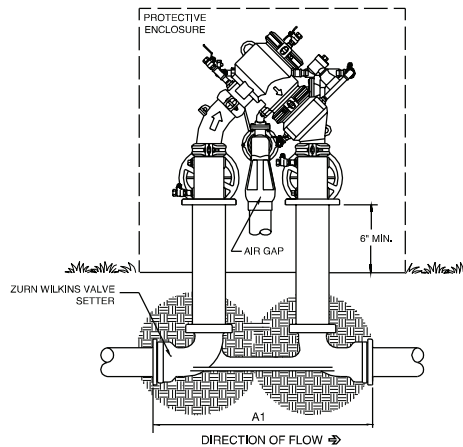

**OUTDOOR INSTALLATION**

MODEL SIZE	DIMENSIONS (approximate)					
	A1 SETTER END TO END FLS		A1 SETTER END TO END MJS			
	in.	mm	in.	mm	in.	mm
4	100	31 5/16	795	29 5/16	745	
6	150	34 3/4	884	32 3/4	832	
8	200	47	1194	44 5/8	1133	
10	250	51	1295	47	1194	

**Specifications**

The Reduced Pressure Detector Assembly shall be certified to NSF/ANSI/CAN 61, ASSE® Listed 1047, and supplied with full port OS & Y gate valves. The main body and access covers shall be epoxy coated ductile iron (ASTM A 536 Grade 4), the seat ring and check valve shall be NORYL™, the stem shall be stainless steel (ASTM A 276) and the seat disc elastomers shall be EPDM. The first and second checks shall be accessible for maintenance without removing the relief valve or the entire device from the line. If installed indoors, the installation shall be supplied with an air gap adapter. The Reduced Pressure Detector Assembly shall be a ZURN WILKINS Model 475DA or 475DAV.