



# Model 310 Detector Check Valve

## Application

Designed for installation on water lines in fire protection systems to protect against both backsiphonage and backpressure of polluted water into the potable water supply. Assembly shall provide protection where a potential health hazard does not exist.

## Standards Compliance

(Unless otherwise noted, applies to sizes 4" & 6")

- Factory Mutual 1045
  - UL® Listed
  - C-UL® Listed
  - NYC MEA 303-02-E
  - Certified to NSF/ANSI 372\* by IAPMO R&T (4" - 8")
- \*(0.25% MAX. WEIGHTED AVERAGE LEAD CONTENT)

**By-Pass Backflow Assembly 3/4" Model 910XL**

## Materials

Main valve body	Ductile Iron ASTM A 536 Grade 4
Access covers	Ductile Iron ASTM A 536 Grade 4
Coatings	NSF Approved fusion epoxy finish
Internals	Stainless steel, 300 Series NORYL™
Fasteners	Stainless Steel, 300 Series
Elastomers	EPDM (FDA approved) Buna Nitrile (FDA approved)
Polymers	NORYL™
Springs	Stainless Steel, 300 Series

## Features

Sizes:	4", 6", 8"
Maximum working water pressure	175 PSI
Maximum working water temperature	140°F
Hydrostatic test pressure	350 PSI
End connections	
(Grooved for steel pipe)	AWWA C606
(Flanged)	ASME B16.42 Class 150



LEAD FREE

LOW-LEAD



## Options

(Suffixes can be combined)

- G - with grooved body
- OSY - with OS & Y gate valves
- DA - with by pass assembly & gpm meter
- DACFM - with by pass & cu ft/min meter
- DALM - with by pass assembly less water meter
- DALMNYC - with by pass assembly less water meter for use with 3/4" x 9" long meters
- DASC FM - with by pass & sensus cu ft/min meter

## Accessories

- Repair kit (rubber only)
- Thermal expansion tank (Model XT)

## By-pass Tapping size

4" Model 310	3/4" NPT only
6" Model 310	3/4" or 1" NPT
8" Model 310	3/4" or 1" NPT

(DA Option only available in 3/4")

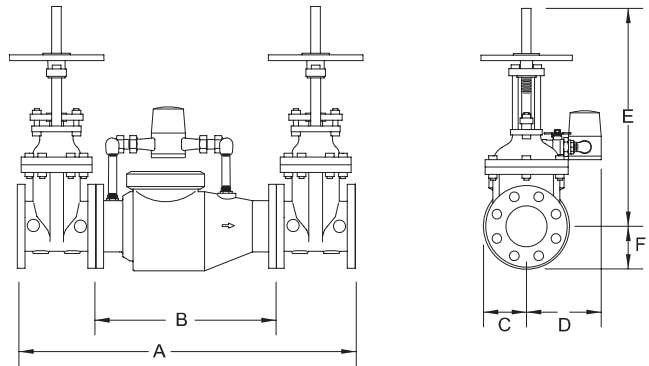

## Dimensions & Weights (do not include pkg.)

Model 310DAOSY shown

MDL SIZE	DIMENSION (approximate)												WEIGHT										
	A		B LESS GATE VALVES		C		D		E OS&Y OPEN		E OS&Y CLOSED		F		MODEL 310 GROOVE D		WITH OSY GATE VALVES		WITH OS&Y GATE VALVES & BY-PASS				
	in.	mm	in.	mm	in.	mm	in.	mm	in.	mm	in.	mm	in.	mm	lbs.	kg	lbs.	kg	lbs.	kg	lbs.	kg	
4	100	34 5/8	880	16 1/2	419	4 1/2	114	8	203	22 3/4	578	18 1/4	464	6	152	63	28.6	39	17.7	253	114.9	259	117.5
6	150	43 5/8	1108	22 1/2	572	6	152	10	254	30 1/8	765	23 3/4	603	7	178	133	60.4	104	47.2	433	196.5	441	200.2
8	200	49 1/2	1257	26 1/2	673	10	254	12	305	37 3/4	959	29 1/4	743	8	203	254	115.3	213	96.7	730	331	741	336.4

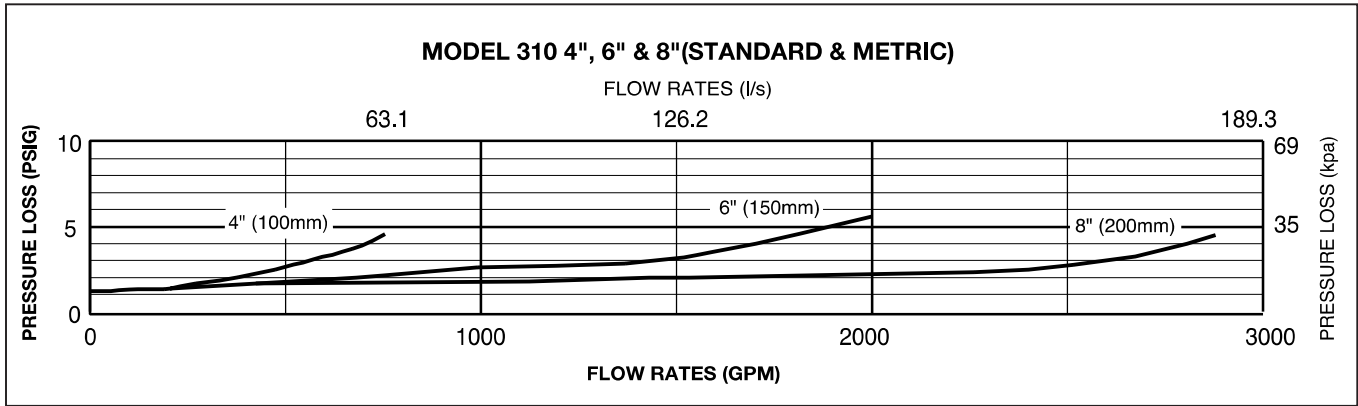

**Typical Installation**

Local codes shall govern installation requirements. Unless otherwise specified, the assembly shall be mounted at a minimum of 12" (305mm) and a maximum of 30" (762mm) above adequate drains with sufficient side clearance for testing and maintenance. The installation shall be made so that no part of the unit can be submerged.

Capacity thru Schedule 40 Pipe (GPM)				
Pipe size	5 ft/sec	7.5 ft/sec	10 ft/sec	15 ft/sec
4"	198	298	397	595
6"	450	675	900	1351
8"	780	1169	1559	2339

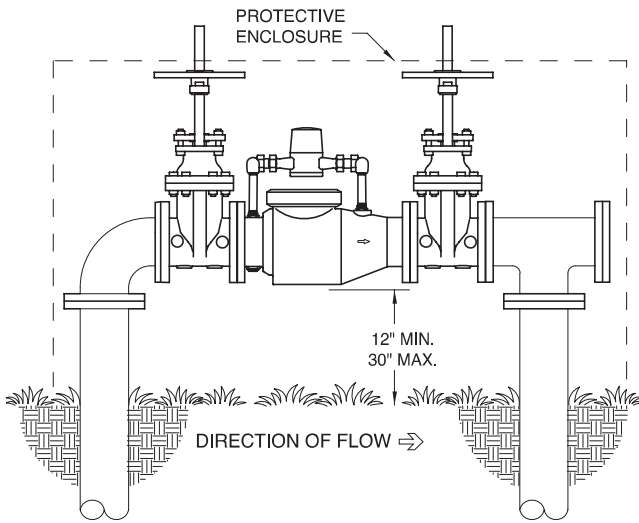

**OUTDOOR INSTALLATION (310DAOSY)**

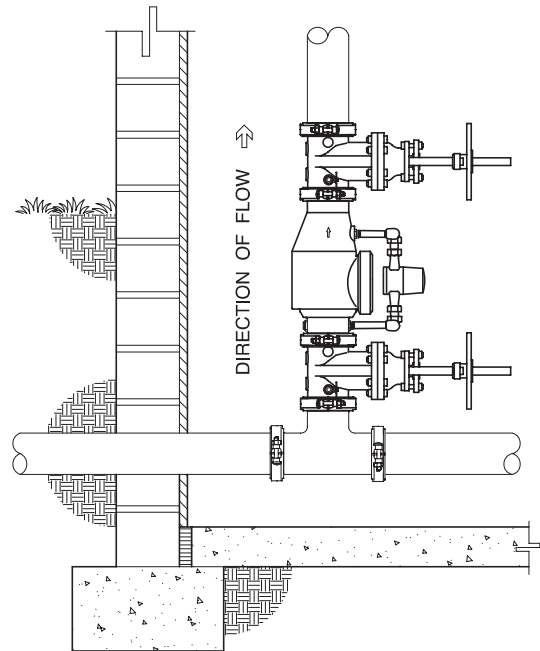

**VERTICAL INSTALLATION (310DAGOSY)**

**Specifications**

The main body and access cover shall be epoxy coated ductile iron (ASTM A 536 Grade 4), the seat ring and check valve shall be Noryl™, the stem shall be stainless steel (ASTM A 276) and the seat disc elastomers shall be EPDM. The check valve shall be spring loaded and accessible for maintenance without removing the device from the line. The Detector Check Valve shall be a ZURN WILKINS Model 310.