

norweco[®]

TRI-MAX[®]

TABLET FEEDER

INSTALLATION AND OPERATION MANUAL

INTRODUCTION

The Tri-Max tablet feeder is a complete dry chemical dosing system for water, wastewater or process water treatment. It is designed to be easily transported from site to site throughout the day or permanently installed by utilizing the mounting holes located on the flow deck. The Tri-Max tablet feeder provides operators a way to use chemical tablets without installing traditional feeders to existing plant piping or assembling liquid chemical dosing systems in the field. A single Tri-Max will treat liquid flows up to 400,000 gallons per day (GPD) or 275 gallons per minute (GPM). The Tri-Max will effectively reduce 50 ppm chlorine to non-detectable levels or add up to 15 ppm chlorine. Constructed completely of heavy duty stainless steel, for maximum strength and durability, the tablet feeder has no electro-mechanical components. The Tri-Max has a variable dosage capability depending upon general component configuration, the flow rate and the type of dechlorination or chlorination tablets used. To insure proper performance and maximize operational life, please take the time to familiarize yourself with the contents of this manual.

HOW THE TRI-MAX WORKS

Designed to accept 2 5/8" diameter molded chemical tablets, the Tri-Max tablet feeder safely applies chemicals into the flow of any treatment system. Flow is channeled across the flow deck where the chemicals are contained in three feed tubes. Active chemicals are released as the liquid erodes the chemical tablets. As the flow rate increases, the liquid level rises and contacts more tablets providing additional chemical release. As the flow rate decreases, the liquid level falls and contacts fewer tablets reducing the chemical dosage. After contact with the chemical tablets, properly treated liquid then flows out of the Tri-Max tablet feeder to the point of discharge.

SYSTEM APPLICATION

The United States Environmental Protection Agency's Stormwater Discharge regulations require that any chlorinated water be dechlorinated prior to final discharge into the environment. Norweco's Tri-Max tablet feeder is a tool which enables treatment system operators to comply with these regulations at minimal cost. Typical applications for the Tri-Max tablet feeder includes dechlorination of fire hydrant and swimming pool backflush, dechlorination or disinfection

of wastewater or potable water discharge, hydrostatic line testing, dead end line flushing and overflow from municipal reservoirs, water towers and cooling towers. The Tri-Max tablet feeder may be installed and adapted for chemical dosage in these and many other treatment applications.

GENERAL INSTALLATION INSTRUCTIONS

A Tri-Max tablet feeder can be incorporated into any treatment system by placing the unit into the flow path. The system should be installed as plumb and level as the site condition will allow. For dechlorination applications, the tablet feeder should be installed at a location

immediately downstream of the discharged chlorinated flow. When used for potable water disinfection, the tablet feeder is typically installed at grade following final filtration and just prior to a storage or contact tank. For wastewater disinfection applications, the tablet feeder is installed following clarification and prior to chlorine contact. Installation can be at grade or below grade. The installation should be accessible for routine maintenance. If permanently mounted, use 3/8" diameter corrosion resistant fasteners to secure the stainless steel flow deck to the discharge of a contact tank, concrete pad or mounting bracket, as required. Make sure the feeder and all other treatment processes are secured for safety and to prevent unauthorized access. Do not mix chlorination and dechlorination tablets within the same tablet feeder.

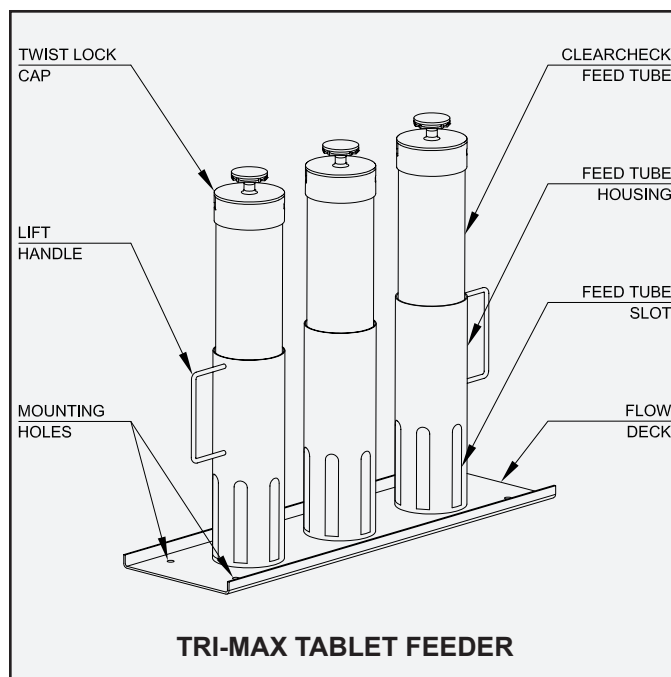

TRI-MAX INSTALLATION AND OPERATION MANUAL

BELOW GRADE INSTALLATION

The Tri-Max tablet feeder may be installed below grade within a manhole or secondary enclosure. The unit is equipped with handles on the outer two feed tube housings to assist with lowering the tablet feeder into a manhole. Remote removal systems are available to allow access to feed tubes in below grade applications.

PLACING THE TRI-MAX UNIT ON-LINE

When the feed tubes are filled with the appropriate chemical tablets, the Tri-Max tablet feeder is ready to be placed on-line. Before starting the flow, check to ensure that the Tri-Max tablet feeder is placed parallel within the anticipated flow. The Tri-Max feeder is most efficient if a laminar (smooth) flow passes over the flow deck. The Tri-Max tablet feeder should be placed on a firm, flat surface with all feed tube slots fully open. Slowly turn on the water flow. Reposition the Tri-Max tablet feeder as necessary to ensure that the maximum amount of flow channels through the unit. After five minutes of operation, draw a sample of the water from a location in close proximity to the point of discharge of the Tri-Max tablet feeder. Use a field test kit to determine if the chemical application rate is appropriate. For dechlorination applications, testing can be done using a sulfite colorimetric test kit. For chlorination applications, testing can be done using a chlorine test kit or a DPD colorimetric test as outlined in the most recent edition of Standard Methods for the Examination of Water and Wastewater.

OPERATIONAL ADJUSTMENT

If the chemical dosage requires alteration, the Tri-Max tablet feeder can be adjusted during operation without taking the unit off-line. When fully inserted into the feeder body, the feed tubes rest on the flow deck. This position provides the maximum chemical dose. Rotating the feed tube clockwise one-quarter ($1/4$) turn from its fully opened position closes the feed tube openings and reduces the chemical dosage. Please refer to the Operational Adjustment Chart at the top of page 3 for routine guidance. If there are additional questions regarding operation, contact your local Tri-Max distributor. For further reference, a red identification tag with the contact information of the manufacturer is attached to the Tri-Max tablet feeder.

INTERMITTENT USAGE

If a period of intermittent use or extended period of non-use is anticipated, the feed tubes containing tablets should be removed and stored in a well-ventilated, dry, secure location. In most cases, partially used tablets can be air dried and reused for further treatment applications. When chlorine tablets are dried, some corrosive levels of chlorine and water are released. Refer to the tablet container label and material safety data sheet for more detailed safety, storage and/or disposal instructions for the chemical tablets.

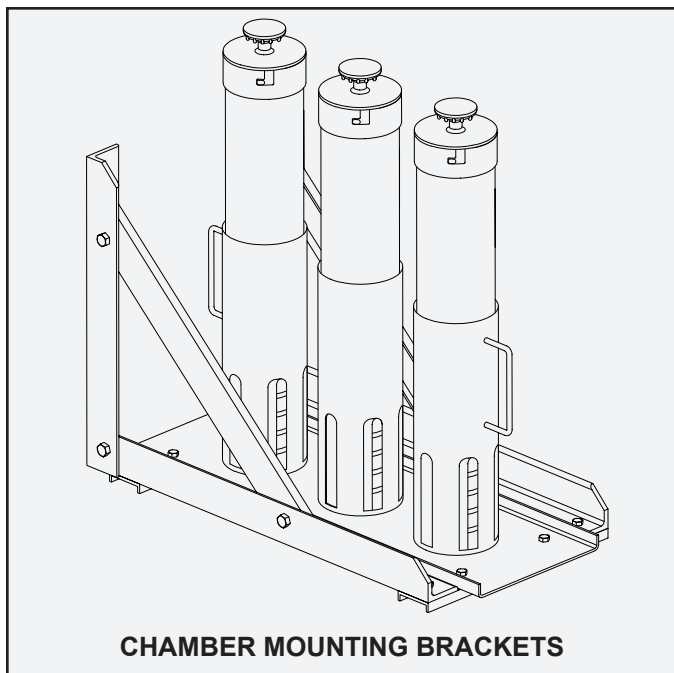

INSTALLATION AT GRADE

The Tri-Max tablet feeder can be installed at grade, on-line or mounted in the contact tank of a water or wastewater treatment system. The installation should be accessible for routine operator maintenance. To mount the Tri-Max, first insure that the unit is level within $1/8$ " side to side and end to end. Place a bubble level on the feeder before final installation to confirm the unit is plumb and level. Then, use $3/8$ " diameter corrosion resistant fasteners to secure the stainless steel flow deck to the contact tank, concrete pad or mounting brackets, as required. For contact tank installations, use corrosion resistant mounting brackets to ensure long term product durability.

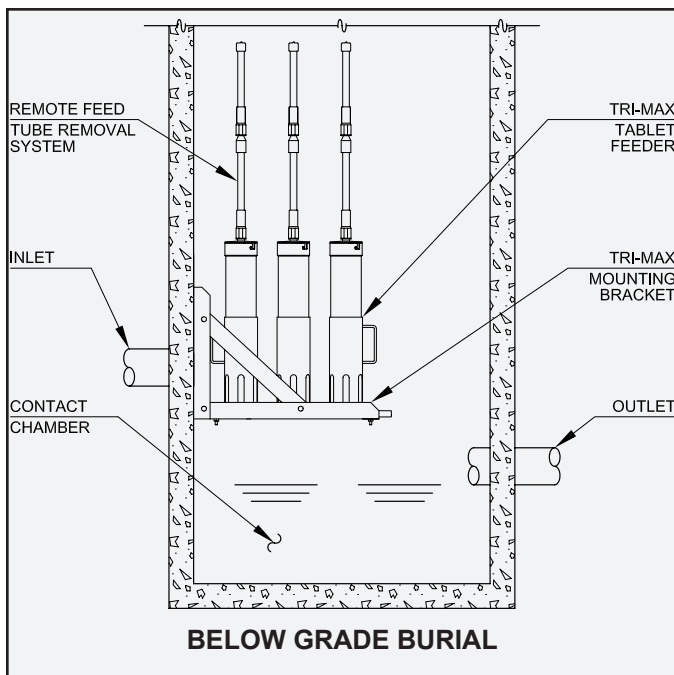

TRI-MAX INSTALLATION AND OPERATION MANUAL

OPERATIONAL ADJUSTMENT CHART		
Condition	Possible Cause	Recommended Remedy
Insufficient Chemical Application	Feed tube empty	Refill chemical tablets
	Incorrect type of tablets used	Replace using approved tablets
	Feed tube not properly installed	Install the feed tube flat on flow deck
	Tablets jammed in the feed tube	Remove, clean and refill the feed tube
	Excess solids in effluent	Troubleshoot treatment plant
	Debris clogging bottom of the feed tube	Remove, clean and refill the feed tube
	Tablet feeder not level	Adjust mounting position
	Tablets more than one year old	Remove, clean and refill the feed tube
Over Application of Chemical	Incorrect type of tablets used	Replace using approved tablets
	Blockage at outlet	Reposition feeder or remove blockage
	Too many tablets immersed	Rotate the feed tube clockwise 90 degrees
	Excessive hydraulic flow	Equalize flow prior to the tablet feeder
	Recirculation piping not properly adjusted	Decrease percentage of recirculation flow
	Tablet feeder not level	Adjust mounting position

ROUTINE MAINTENANCE

The Tri-Max tablet feeder requires little maintenance other than cleaning and refilling of the feed tubes. When performing any maintenance, always wear rubber gloves and safety goggles and follow the procedures outlined in the handling instructions for the chemicals used. Before refilling the feed tubes, rinse each tube and cap thoroughly with fresh water. Occasionally, a feed tube may need to be cleaned with a brush. When refilling feed tubes, check the inside of the feeder and rinse any residue with a low pressure hose. The liquid flow will normally prevent accumulation of debris during routine operation. Lodged debris within the feeder can be removed with the cleaning brush or a gloved hand.

REMOTE REMOVAL SYSTEM

Remote feed tube removal systems are available for below grade installations for safe removal, recharge and reinstallation of feed tubes from grade. The system consists of a top-threaded feed tube cap, one corrosion resistant 12" extension and one corrosion resistant 12" handle. For use, replace the standard cap with the top-threaded cap. The extension and handle are threaded onto the top of the new cap. The feed tube is then returned to its proper position within the tablet feeder. Additional extensions are available and can be added or removed at any time. The extensions and handles remain in place during system operation. Standard feed tube filling instructions apply.

CLEARCHECK® FEED TUBE AND CAP

The Tri-Max tablet feeder is equipped with molded, one-piece chemical feed tubes with twist lock caps. Each feed tube and cap are constructed of NSF/ANSI Standard 61 listed PVC for durability and long life. The feed tube is manufactured with the translucent ClearCheck design. This design allows the operator or service provider to determine whether tablet refill is required simply by visual inspection without removing the tube from the feeder. Incorporated into the feed tube are six feed tube slots. Each slot is 4 3/4" in height and 3/4" in width. When the feed tube is filled, five tablets are exposed to the water flow. These exposed tablets provide the chemical dosage for treatment. Chemical dosage can be changed by turning the feed tubes one-quarter (1/4") turn to reduce or increase the amount of tablets exposed to the flow. The feed tube utilizes chemical tablets with the nominal weight and dimensions of 5 ounces, 2 5/8" diameter and 13/16" to 1" height. Slots molded directly into the bottom of the feed tube allow the chemical tablets to dry during intermittent or prolonged periods of no flow.

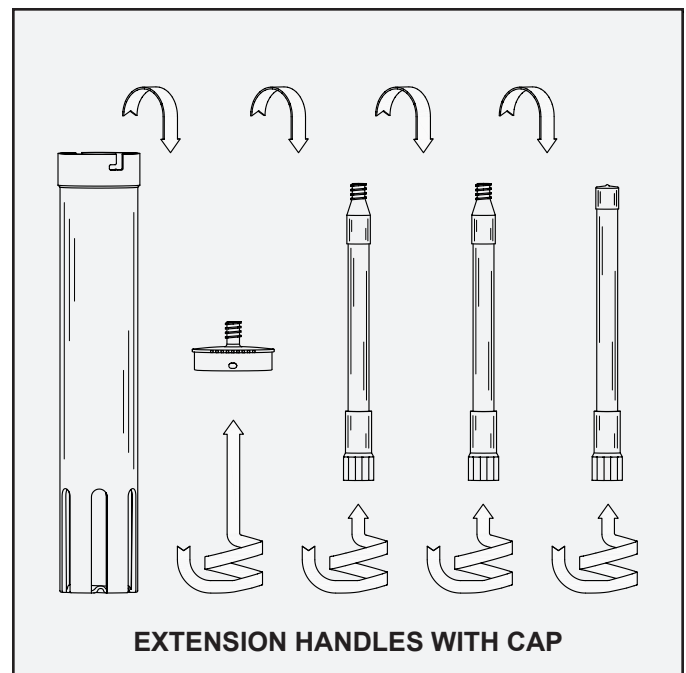

TRI-MAX INSTALLATION AND OPERATION MANUAL

FILLING AND INSTALLING THE FEED TUBE

Before handling any chemical tablets, carefully read the product container label and the **CAUTION** sections of these instructions. When filling the feed tube, always wear rubber gloves and safety goggles or a face shield for proper protection. Follow all handling instructions for the chemical tablets used. To fill the feed tube, remove it from the feeder. Rinse the feed tube and cap thoroughly with fresh water. Dry as required. Hold the tube, slotted end up, at a 30° to 45° angle and slide the chemical tablets into the open feed tube, one tablet at a time. Insure that each tablet lies flat against the next and evenly on top of one another in the feed tube. Use a gloved hand to retain the tablets inside the open end of the inverted tube until it has been evenly and completely filled. Carefully return the tube to the upright position. Replace the cap and slide the feed tube into the body of the feeder, slotted end down. Be sure the feed tube rests evenly on the flow deck. Utilize the Chemical Consumption Record on the back of this manual to track the chemical refill pattern.

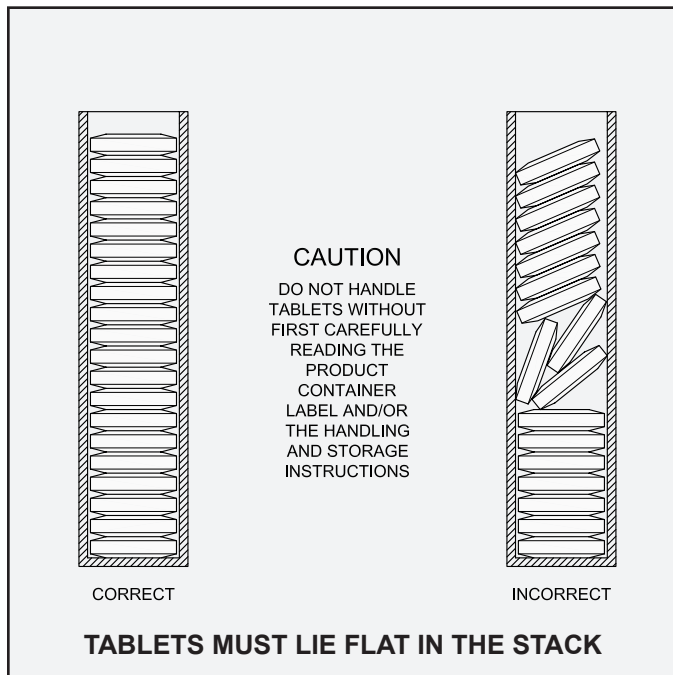

FEED TUBE CLEANING BRUSH

A brush for cleaning the feed tubes and flow deck is available from your local Tri-Max distributor. The feed tube cleaning brush can also be used to clean plumbing contained within the wastewater plant prior to sampling. To use the brush, remove the extension handle from the top-threaded feed tube cap and screw the brush into the handle. Wet the brush with fresh water, hold the feed tubes over the tablet feeder and gently swab the inside of each feed tube. Lower the brush into the tablet feeder and through the openings in the stationary insert. Clean the flow deck and inside of the feeder. Thoroughly rinse and remove the brush, attach the top-threaded feed tube cap to the handle and reinstall the feed tube into the tablet feeder.

COMPONENT CONFIGURATION

The Tri-Max tablet feeder provides a chemical dose in direct correlation to the amount and velocity of the incoming flow. The anticipated flow rate and desired chemical application rate of the system should be estimated to properly configure the tablet feeder for operation. The flow rate can be determined by engineering design estimates or by using a system flow meter, lift station capacity with number of pumping cycles, flow counter or water meter records. Once the feeder is set into place, the primary methods used to regulate chemical dosage are to add or remove filled feed tubes or reposition the feeder.

The following charts provide preliminary configuration for common Tri-Max applications. This information should be used for guidance only and is not a substitute for proper empirical based adjustments.

Dechlorination				
Flow in GPM	Number of feed tubes required to remove various levels of chlorine			
	5 ppm	10 ppm	25 ppm	50 ppm
50	1	1	2	3
100	1	2	3	3*
150	2	2	3	3*
200	2	2	3*	3*
250	2	3	3*	3*
300	2	3	3*	3*

* To remove maximum levels of chlorine at flows greater than 100 GPM, tablets must be preconditioned. To precondition tablets, fill the inner plastic feed tube with tablets. Place the plastic feed tube in water and let them soak for one hour. Remove the feed tube and replace it in the Tri-Max tablet feeder.

Chlorination				
Flow in GPM	Number of feed tubes required to provide various levels of chlorine			
	1 ppm	5 ppm	10 ppm	15 ppm
50	1	2	2	3
100	1	2	3	3
150	1	2	3	3
200	2	3	3	3
250	2	3	3	3
300	3	3	3	3

Disinfection requires a contact time following chemical addition. Contact your regulatory authority for application specific guidance.

TRI-MAX INSTALLATION AND OPERATION MANUAL

BIO-MAX® DECHLORINATION TABLETS

If the tablet feeder is to be used for the dechlorination of water or wastewater, a (10 lb. or 48 lb.) supply of Bio-Max dechlorination tablets is available from your local distributor. Containing 92% sodium sulfite, the dechlorination tablets are manufactured to neutralize both free and combined chlorine. Bio-Max dechlorination tablets incorporate beveled edges to enhance the chemical dissolution pattern. Each tablet is 2⁵/₈" diameter, compressed to a 1³/₁₆" thickness, weighs approximately 5 ounces and is green in color for easy identification. The dechlorination tablets dissolve slowly, releasing controlled amounts of chemical for the instantaneous removal of residual chlorine from the water or wastewater flow. The chemical application rate of the Bio-Max dechlorination tablets remains consistent at peak flow factors as high as four. Bio-Max dechlorination tablets are formulated to remove chlorine residuals to non-detectable levels.

BIO-NEUTRALIZER® DECHLORINATION TABLETS

If the tablet feeder is to be used for the dechlorination of water or wastewater, a (25 lb. or 45 lb.) supply of Bio-Neutralizer dechlorination tablets is available from your local distributor. Bio-Neutralizer tablets are formulated to completely dechlorinate during the low, sustained, variable and intermittent flow rates that are common to residential wastewater treatment systems. Containing 35% sodium sulfite, the Bio-Neutralizer dechlorination tablets are manufactured to neutralize both free and combined chlorine. Bio-Neutralizer dechlorination tablets incorporate beveled edges to enhance the chemical dissolution pattern. Each tablet is 2⁵/₈" diameter, compressed to a 1³/₁₆" thickness, weighs approximately 5 ounces and is green in color for easy identification. The Bio-Neutralizer tablets dissolve slowly, releasing controlled amounts of chemical for the instantaneous removal of residual chlorine from the water or wastewater flow. The chemical application rate of the dechlorination tablets remains consistent at peak flow factors as high as four.

CAUTION: *The improper handling of Bio-Max or Bio-Neutralizer dechlorination tablets may cause personal injury or property damage. Keep out of the reach of children and do not allow the tablets or feed tubes to contact skin, eyes or clothing. Tablets may be fatal if swallowed and tablet dust is irritating to the eyes, nose and throat. Do not handle the tablets or feed tubes without first carefully reading the product container label, material safety data sheet (SDS) and the safety, handling and storage instructions. Do not add tablets to any dispensing device or storage container containing remnants of any other product, especially petroleum based products or swimming pool chlorine. For additional information about Bio-Max or Bio-Neutralizer dechlorination tablets, contact your local distributor.*

BIO-SANITIZER® DISINFECTING TABLETS

If the tablet feeder is to be used for the disinfection of water or wastewater, a (10 lb., 25 lb., 45 lb. or 100 lb.) supply of Bio-Sanitizer disinfecting tablets is available from your local distributor. Bio-Sanitizer disinfecting tablets insure dependable disinfection for water and wastewater treatment system flow and other applications where a predictable long-term source of chlorine is desirable. The Bio-Sanitizer tablets are manufactured from pure calcium hypochlorite and contain at least 70% available chlorine. Registered with the USEPA for water and wastewater treatment, the tablets incorporate beveled edges to enhance the chemical dissolution pattern, providing effective and economical bacteria killing power. Each tablet is 2⁵/₈" diameter, compressed to a 1³/₁₆" thickness, has an approximate weight of 5 ounces and is white in color for easy identification. The chemical application rate of the tablets remains consistent at peak flow factors as high as four.

BLUE CRYSTAL® DISINFECTING TABLETS

If the tablet feeder is to be used for the disinfection of residential wastewater, a (10 lb. or 100 lb.) supply of Blue Crystal residential disinfecting tablets is available from your local distributor. The tablets are specifically developed for applications which require higher dosages of chlorine, such as nitrogen reduction, septic effluent disinfection, odor control and shock disinfection. Blue Crystal disinfecting tablets are formulated to maintain positive disinfection during the low, sustained, variable and intermittent flow rates that are common to residential wastewater treatment systems. The Blue Crystal disinfecting tablets are manufactured from pure calcium hypochlorite and contain at least 70% available chlorine. Registered with the USEPA for wastewater treatment, the tablets incorporate beveled edges to enhance the chemical dissolution pattern, providing effective and economical bacteria killing power. Each tablet is 2⁵/₈" diameter, compressed to a 1" thickness, has an approximate weight of 5 ounces and is white in color with blue crystals for easy identification.

CAUTION: *The improper handling of Bio-Sanitizer or Blue Crystal tablets may cause personal injury or property damage. Keep out of the reach of children and do not allow the tablets or feed tubes to contact skin, eyes or clothing. Tablets may be fatal if swallowed and tablet dust is irritating to the eyes, nose and throat. Do not handle the tablets or feed tubes without first carefully reading the product container label, SDS and/or the handling and storage instructions. Do not add tablets to any dispensing device or storage container containing remnants of any other product, especially petroleum based products or swimming pool chlorine. Do not use swimming pool chemicals in the Tri-Max feeder. For additional information about Bio-Sanitizer or Blue Crystal tablets contact your local distributor.*

BIO-PERC® REMEDIATION TABLETS

If the tablet feeder is to be used for the bioaugmentation of wastewater, a 10 lb. supply of Bio-Perc biological remediation tablets is available from your local distributor. Bio-Perc tablets rejuvenate failing wastewater treatment systems by reducing or eliminating organic buildup in distribution lines and disposal processes. Bio-Perc biological remediation tablets help sand filters and soil-based treatment systems recover their infiltrative capacity while preventing the failure of new installations. Each tablet is 2⁵/₈" diameter, compressed to a 1" thickness, has an approximate weight of 5 ounces, is tan in color and incorporates a beveled edge design to reduce wicking.

CAUTION: All chemicals and chemical feed systems should be handled with care. Chemicals and feed tubes should not be mixed with each other or any other products. Do not handle tablets or feed tubes without first carefully reading the product container label, SDS information and the handling and storage instructions.

TRI-MAX™ LIMITED WARRANTY

The Tri-Max tablet feeder is backed by a comprehensive ten year limited warranty. The purchaser is protected from defects in material and workmanship, under normal use and service, for a period of ten years from the date of original purchase. The Tri-Max distributor will provide a warranty registration card, as well as detailed warranty information, to each purchaser. This warranty is not effective unless the warranty registration card is returned to the factory within 30 days of purchase. If the Tri-Max unit or feed tubes require service or replacement, do not use the unit. Contact your local, authorized Tri-Max distributor to arrange for replacement of the system or component. After inspection, the distributor will return the tablet feeder or component to the factory and replace the necessary items according to the terms of the limited warranty. Use of chemical tablets not produced or approved by Norweco may effect the integrity of your Tri-Max unit and void the ten year limited warranty.

TRI-MAX™ CHEMICAL CONSUMPTION RECORD

For your reference, please document chemical consumption and maintenance on the following chart:

DATE	DESCRIPTION



220 REPUBLIC STREET
 NORWALK, OHIO, U.S.A. 44857
 TELEPHONE (419) 668-4471
 FAX (419) 663-5440
www.norweco.com

DISTRIBUTED LOCALLY BY: