



DOC022.53.80457

SL1000

08/2017, Edition 5

User Manual

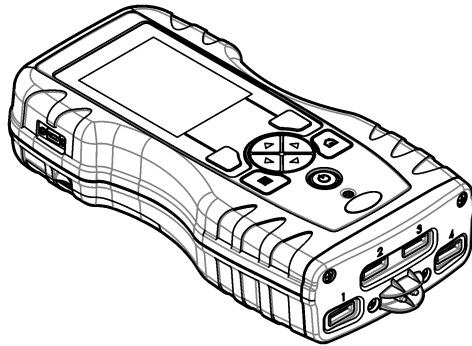

Specifications	3
General information	3
Safety information	3
Use of hazard information	4
Precautionary labels	4
Certification	4
Product overview	5
Product components	5
Installation	5
Lithium battery safety	6
Install the battery	6
Charge the battery	7
Install the hand strap	7
User interface and navigation	8
Display description	8
Keypad description	9
Startup	10
Set the power to on	10
Change the language	10
Change the date and time	10
Standard operation	10
Use an operator ID	10
Use a site ID	10
Complete Chemkey measurements	11
Connect a probe	12
Complete probe measurements	13
Calibration	14
Calibrate the probe	14
Factory calibration	14
Calibrate the meter for a specific Chemkey parameter	15
Probe verification	15
Chemkey verification	15
Data log	15
Import data to Excel	16
Look at data in a web browser	16
Advanced operation	16
Configure the meter	16
Select the Chemkey settings	17
Select the probe settings	18
Select the pH options	18
Select the conductivity options	19
Select the LDO options	20
Select the salinity correction factor	20
Select the fluoride options	21

Table of Contents

Select the nitrate options	22
Select the chloride options	22
Select the sodium options	23
Select the ammonium options	24
Select the ORP options	25
Add operators, notes, sites and routes	25
Set up routes	26
See the system information	27
Upgrade the meter software	27
Maintenance	27
Clean spills	28
Clean the instrument	28
Clean or replace parts	28
Charge or replace the battery	29
Prepare for shipping	30
Troubleshooting	30
Do a diagnostic check	31
Replacement parts and accessories	32

Specifications

Specifications are subject to change without notice.

Specification	Details
Dimensions (W x D x H)	13.08 x 5.89 x 25.83 cm (5.15 x 2.32 x 10.17 in.)
Enclosure rating	IP64 with caps installed for the meter probe connector ports or with the probes connected to the instrument
Weight	1.2 kg (2.7 lb)
Power requirements (internal)	Lithium ion rechargeable battery
Power requirements (external)	100V–240 VAC, 50/60Hz input, 12V at 3A output
Operating temperature	5 to 50 °C (41 to 122 °F), maximum 85% relative humidity (non-condensing)
Storage temperature	–20 to 60 °C (–4 to 140 °F), maximum 85% relative humidity (non-condensing)
Interface	Mini USB port
5-pin input connector	Two M12 connectors for IntelliCal™ probes
External power supply connection	2.5 mm Jack
Chemkey slots	4
Data memory	1000 measured values (result, date, time, site ID, user ID)
Data storage	Automatic in Press to Read measurement mode. Manual in Continuous measurement mode
Temperature correction (for IntelliCal™ probes)	Off, automatic and manual (parameter dependent)
Measurement display lock (for IntelliCal™ probes)	Press to Read and Continuous measurement mode
Protection class	III
Certifications	CE compliant
Warranty	1 year

General information

In no event will the manufacturer be liable for direct, indirect, special, incidental or consequential damages resulting from any defect or omission in this manual. The manufacturer reserves the right to make changes in this manual and the products it describes at any time, without notice or obligation. Revised editions are found on the manufacturer's website.

Patents associated with this product, if any, may be found at: www.hach.com/patentlabel.

Safety information

NOTICE

The manufacturer is not responsible for any damages due to misapplication or misuse of this product including, without limitation, direct, incidental and consequential damages, and disclaims such damages to the full extent permitted under applicable law. The user is solely responsible to identify critical application risks and install appropriate mechanisms to protect processes during a possible equipment malfunction.

Please read this entire manual before unpacking, setting up or operating this equipment. Pay attention to all danger and caution statements. Failure to do so could result in serious injury to the operator or damage to the equipment.



Make sure that the protection provided by this equipment is not impaired. Do not use or install this equipment in any manner other than that specified in this manual.

Use of hazard information

▲ DANGER
Indicates a potentially or imminently hazardous situation which, if not avoided, will result in death or serious injury.
▲ WARNING
Indicates a potentially or imminently hazardous situation which, if not avoided, could result in death or serious injury.
▲ CAUTION
Indicates a potentially hazardous situation that may result in minor or moderate injury.
NOTICE
Indicates a situation which, if not avoided, may cause damage to the instrument. Information that requires special emphasis.

Precautionary labels

Read all labels and tags attached to the instrument. Personal injury or damage to the instrument could occur if not observed. A symbol on the instrument is referenced in the manual with a precautionary statement.

	This symbol, if noted on the instrument, references the instruction manual for operation and/or safety information.
	Electrical equipment marked with this symbol may not be disposed of in European domestic or public disposal systems. Return old or end-of-life equipment to the manufacturer for disposal at no charge to the user.

Certification

EN 55011/CISPR 11 Notification Warning

This is a Class A product. In a domestic environment this product may cause radio interference in which case the user may be required to take adequate measures.

Canadian Radio Interference-Causing Equipment Regulation, IECS-003, Class A:

Supporting test records reside with the manufacturer.

This Class A digital apparatus meets all requirements of the Canadian Interference-Causing Equipment Regulations.

Cet appareil numérique de classe A répond à toutes les exigences de la réglementation canadienne sur les équipements provoquant des interférences.

FCC Part 15, Class "A" Limits

Supporting test records reside with the manufacturer. The device complies with Part 15 of the FCC Rules. Operation is subject to the following conditions:

1. The equipment may not cause harmful interference.
2. The equipment must accept any interference received, including interference that may cause undesired operation.

Changes or modifications to this equipment not expressly approved by the party responsible for compliance could void the user's authority to operate the equipment. This equipment has been tested and found to comply with the limits for a Class A digital device, pursuant to Part 15 of the FCC rules. These limits are designed to provide reasonable protection against harmful interference when the

equipment is operated in a commercial environment. This equipment generates, uses and can radiate radio frequency energy and, if not installed and used in accordance with the instruction manual, may cause harmful interference to radio communications. Operation of this equipment in a residential area is likely to cause harmful interference, in which case the user will be required to correct the interference at their expense. The following techniques can be used to reduce interference problems:

1. Disconnect the equipment from its power source to verify that it is or is not the source of the interference.
2. If the equipment is connected to the same outlet as the device experiencing interference, connect the equipment to a different outlet.
3. Move the equipment away from the device receiving the interference.
4. Reposition the receiving antenna for the device receiving the interference.
5. Try combinations of the above.

Product overview

The SL1000 portable parallel analyzer measures a maximum of six parameters at the same time in drinking water and other clean water applications. The meter uses Chemkeys® and digital IntelliCAL™ probes to measure different parameters in water. The meter automatically identifies the type of Chemkey that is installed or the type of probe that is connected to the meter.

The meter can use a maximum of four Chemkeys and a maximum of two probes for measurements. Refer to [Figure 1](#).

Figure 1 Product overview

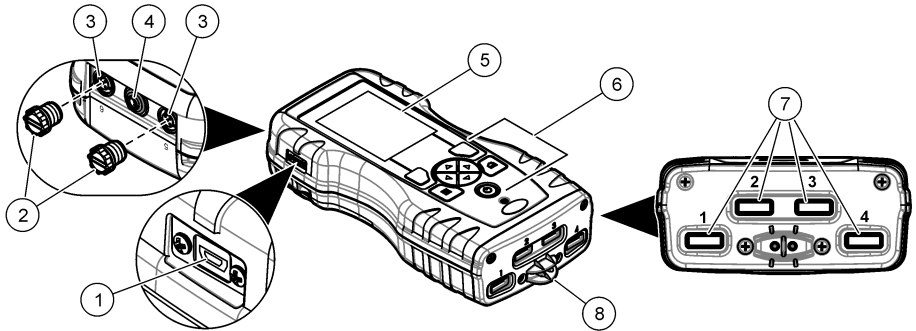

1 Mini USB port	5 Display
2 Probe connector port caps	6 Keypad
3 Probe connection ports	7 Chemkey slots
4 Power access port	8 Sample detector

Product components

Make sure that all components have been received. Refer to the supplied packaging guide. If any items are missing or damaged, contact the manufacturer or a sales representative immediately.

Installation

⚠ WARNING



Multiple hazards. Only qualified personnel must conduct the tasks described in this section of the document.

Lithium battery safety

▲ WARNING



Fire and explosion hazard. Lithium batteries may get hot, explode or ignite and cause serious injury if exposed to abuse conditions.

- Do not use the battery if there is visible damage.
- Do not use the battery after strong shock or vibration occurs.
- Do not expose the battery to fire.
- Keep the battery at temperatures less than 60 °C (140 °F).
- Keep the battery dry and away from water.
- Prevent contact between the positive and negative battery terminals.
- Do not let unauthorized persons touch the battery.
- Discard the battery in accordance with local, regional and national regulations.

Install the battery

▲ WARNING



Fire and explosion hazard. This equipment contains a high energy lithium battery which can ignite and cause fire or explosion, even without power. To maintain the safety provided by the instrument enclosure, the instrument enclosure covers must be installed and secured with the supplied hardware.

Only use the supplied lithium battery. Refer to [Figure 2](#) for battery installation or removal.

Figure 2 Battery installation and removal

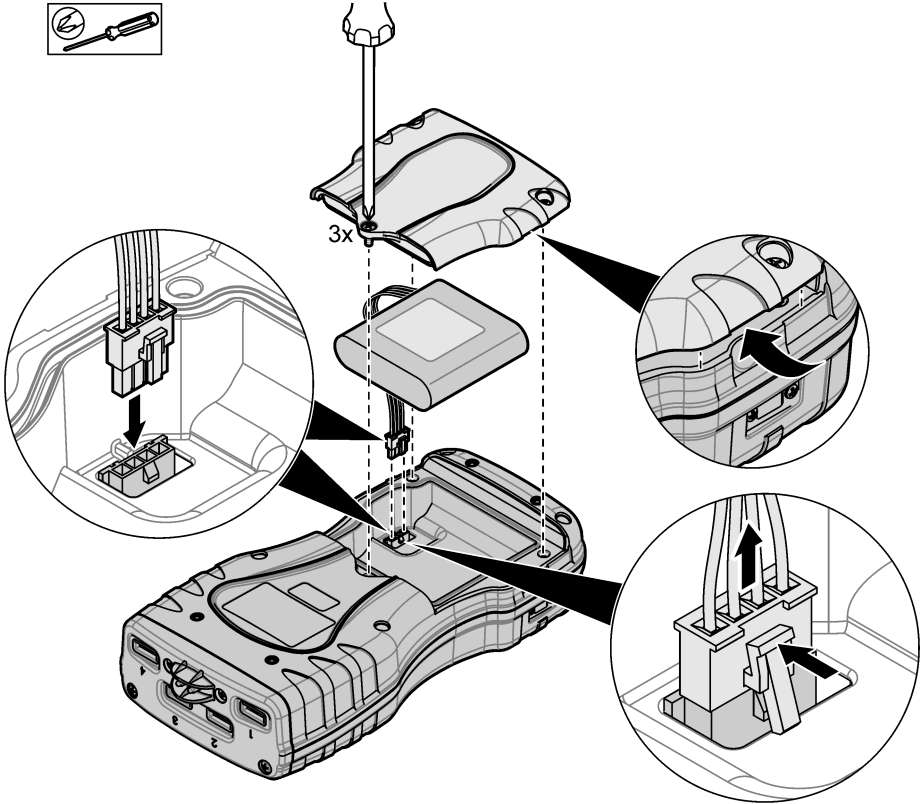

Charge the battery

⚠ WARNING



Fire hazard. Use only the external power supply that is specified for this instrument.

1. Connect the external power supply to an AC mains outlet socket.
2. Connect the external power supply to the power access port on the meter. Refer to [Product overview](#) on page 5.
 - The instrument can be operated while the battery charges.
 - External power supply substitution is not permitted. Use only the external power supply specified in the list of parts and accessories for the instrument. Refer to [Replacement parts and accessories](#) on page 32.
 - Do not charge the battery for more than 24 hours.

Install the hand strap

Install the hand strap to safely hold the meter. Refer to [Figure 3](#).

Figure 3 Hand strap installation

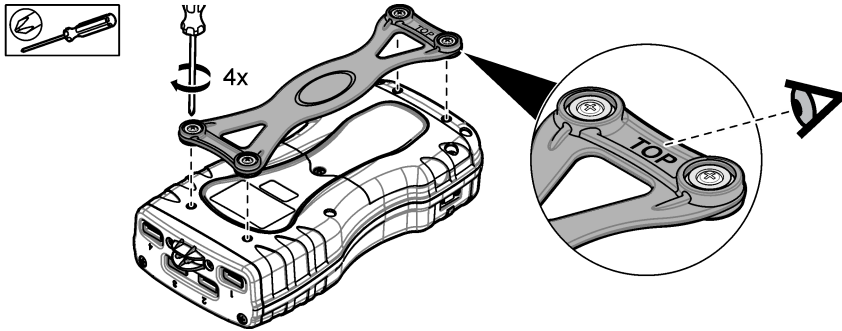

User interface and navigation

Display description

Refer to [Figure 4](#) and [Figure 5](#) for the measurement screen description.

Figure 4 Measurement screen (top part)

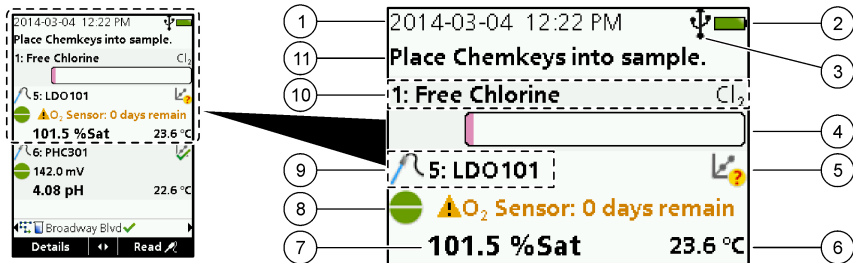

1 Date and time	7 Primary measurement value (user-selected parameter)
2 Battery status	8 Stability icon with warning icon and warning message
3 USB (COM port) active connection icon when communication class is selected	9 Probe icon, port number, parameter or probe name
4 Progress bar (not completed measurement)	10 Slot number, parameter name and chemical symbol
5 Calibration status icon (calibration not correct)	11 Very important message for devices (followed by error and then warning message)
6 Secondary measurement (user-selected parameter)	

Figure 5 Measurement screen (lower part)

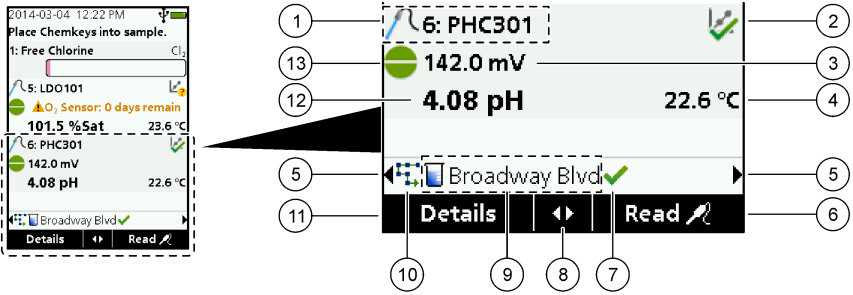

1 Probe icon, port number, parameter or probe name	8 Active arrow keys
2 Calibration status icon (calibration correct)	9 Site ID icon and site name
3 Secondary measurement value (user-selected parameter)	10 Routes icon (shows when routes is set to on)
4 Tertiary measurement value (user-selected parameter)	11 Options (contextual: Details, exit, cancel, select, deselect)
5 Right and left arrows to select the applicable site ID	12 Primary measurement value (user selected)
6 Options (contextual: Read, select, OK, delete)	13 Stability icon
7 Checkmark: Completed measurement on site	

Keypad description

Refer to [Figure 6](#) for the keypad description and navigation information.

Figure 6 Keypad description

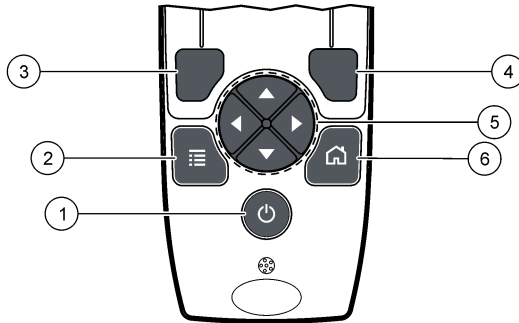

1 POWER key	4 RIGHT selection key (contextual): Read samples, delete, select or confirm options, opens sub-menus
2 MAIN MENU key: Select verification, calibration, routes, settings, data log, information, diagnostics, operator ID and site ID	5 Navigation keys UP, DOWN, RIGHT, LEFT ¹ : Scroll through menus, enter numbers and letters.
3 LEFT selection key (contextual): Details, select/deselect, cancels or exits the current menu screen to the previous one	6 HOME: Go to the main measurement screen.

¹ UP, DOWN: Scroll through measurements when there are more than four measurements, RIGHT, LEFT: Scroll through operator and sample IDs.

Startup

Set the power to on

Push the **POWER** key to set the meter to on or off. If the meter does not power on, make sure that the battery is correctly installed.

Change the language

Select the display language when the meter is set to on for the first time. Change the language from the **Settings** menu.

1. Push **Settings>Language**.
2. Select the applicable language.

Change the date and time

There are two options to set the date and time and format:

- Set the date and time when the meter is set to on for the first time.
- Set the date and time from the Date & Time menu.

1. Select **Settings>Meter>Date & Time**.
2. Use the arrow keys to select the format for the date and time and then enter the current time and date information.
The current date and time will be shown on the display and on the logged measurement data.

Standard operation

Use an operator ID

The operator ID tag associates measurements with an individual operator. All stored data will include the operator ID.

To easily manage operator IDs, use the web application "tool.htm". Refer to [Add operators, notes, sites and routes](#) on page 25.

1. Push **Main Menu>Operator ID**.
2. Select an option.

Option	Description
Mode	Set the Operator ID function to on or off (default).
Select	Select an ID from a list. The current ID will be associated with sample data until a different ID is selected. Use the UP and DOWN arrows to select an operator ID from the home screen. It is possible to select the operator ID on the measurement screen before a Chemkey is in the slot or a probe is attached.
Create	Enter a name for a new operator ID.
Delete	Erase an existing operator ID.

Use a site ID

Select the site ID tag to associate measurements with a particular sample or with a location. If assigned, stored data will include this ID.

To easily manage site IDs, use the web application "tool.htm". Refer to [Add operators, notes, sites and routes](#) on page 25.

1. Push **Main Menu>Site ID**.
2. Select an option.

Option	Description
Mode	Set the Site ID function to manual, auto, off or routes. Manual —Select a site ID manually. Auto —The samples are numbered in sequence for each measurement until a different ID is selected. Off —The site ID function is set to off (default). Routes —Supplies an ordered subset of the complete site ID list.
Select	Select an ID from a list. The current ID will be associated with the sample data until a different ID is selected. Set Site ID>Show to Yes. Use the RIGHT or LEFT arrow to select the current site ID on the measurement screen. Make sure that Site ID>Show is set to Yes and at least one Chemkey is in the slot or one probe is attached.
Create	Add a new site ID.
Delete	Erase existing site ID(s). Note: Make sure to select the Manual mode to delete a site ID.
Show	Shows the site ID on the measurement screen. Set to on or off.
Routes	Supplies an ordered list of site IDs. If a route is selected, the site IDs automatically show on the measurement screen and are recorded. Push the RIGHT arrow to select the next location. Use the web application "tool.htm" to set up the routes. Refer to Add operators, notes, sites and routes on page 25 for more information.
Notes	Record special information and add this information to an event log.

Complete Chemkey measurements

NOTICE

Do not start a new Chemkey measurement when other Chemkey measurements are not yet completed. Only put the meter in the sample once for a Chemkey measurement.

To complete a measurement with the Chemkey(s), do the procedure that follows. Refer to [Figure 7](#). Multiple probe measurements can be completed at the same time. Refer to [Complete probe measurements](#) on page 13.

1. Set the meter power to on.
2. If complete traceability is necessary, enter a site ID and operator ID before measurement. Refer to [Use an operator ID](#) on page 10 and [Use a site ID](#) on page 10.
3. Push the applicable Chemkey(s) fully, in one movement, into the slot(s) 1 to 4. Make sure to always use a new Chemkey for each measurement. It is important to push the Chemkey all of the way into the slot.
When a Chemkey is in a slot, do not move or touch the Chemkey.²
4. Rinse the sample cup with the sample.
5. Fill the meter sample cup to the fill-line with the sample.
6. Put the meter into the meter sample cup.
7. Wait for the sound alert and/or the meter removal animation (within 1 to 2 seconds), then immediately remove the meter from the sample cup.
Put the meter back into the case and wait until the measurement is completed. The parameters have different reaction times. The display shows a progress bar with the time that remains until the measurement is completed.
8. The measurement values are shown on the display.
Note: When an error shows, push **Details** for more information.

² A monochloramine Chemkey and a free ammonia Chemkey are both necessary to obtain a free ammonia measurement.

Figure 7 Chemkey sample measurement

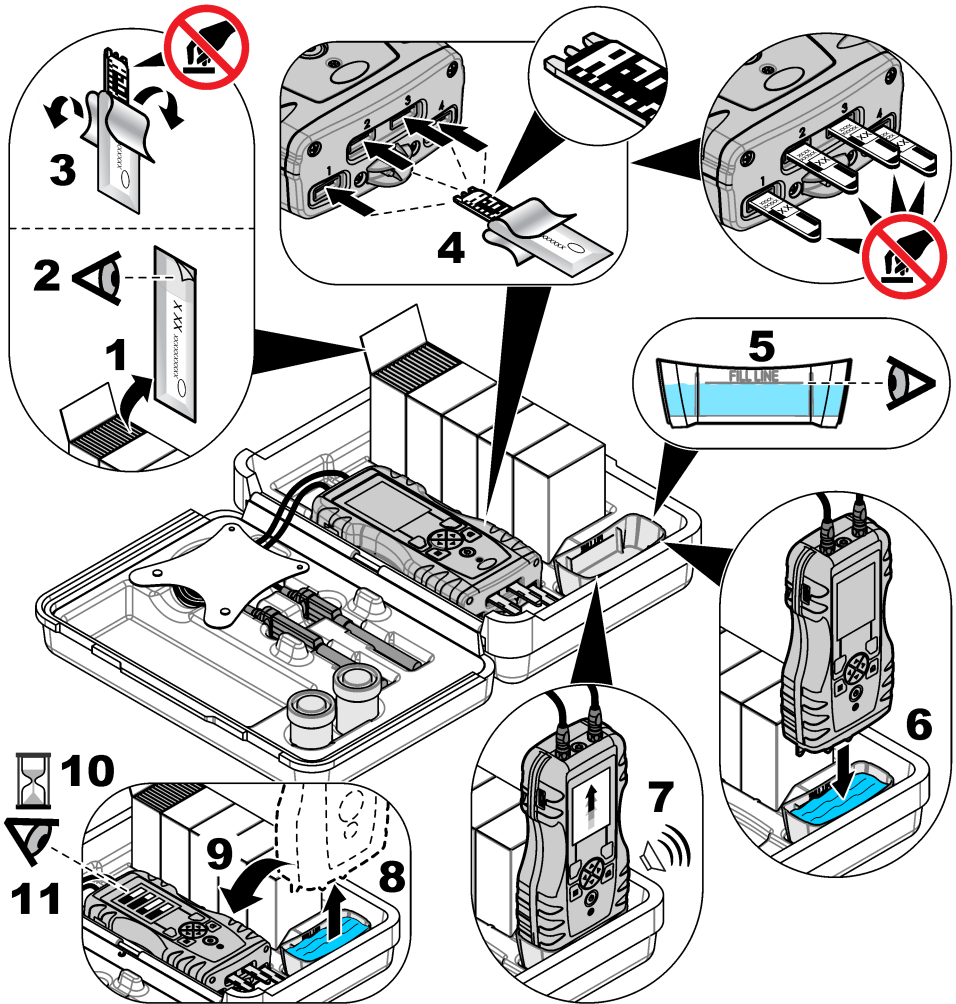

Connect a probe

NOTICE

Do not discard the probe connector port caps. Make sure that the probe connector port caps are installed when no probe is connected.

Make sure that the display shows the current time and date and then plug the probe into the meter. Refer to [Figure 8](#).

Note: The time stamp for a probe is set when the probe is first connected to the meter. This time stamp makes it possible to record the probe history and record the time when measurements are made.

Figure 8 Probe connections

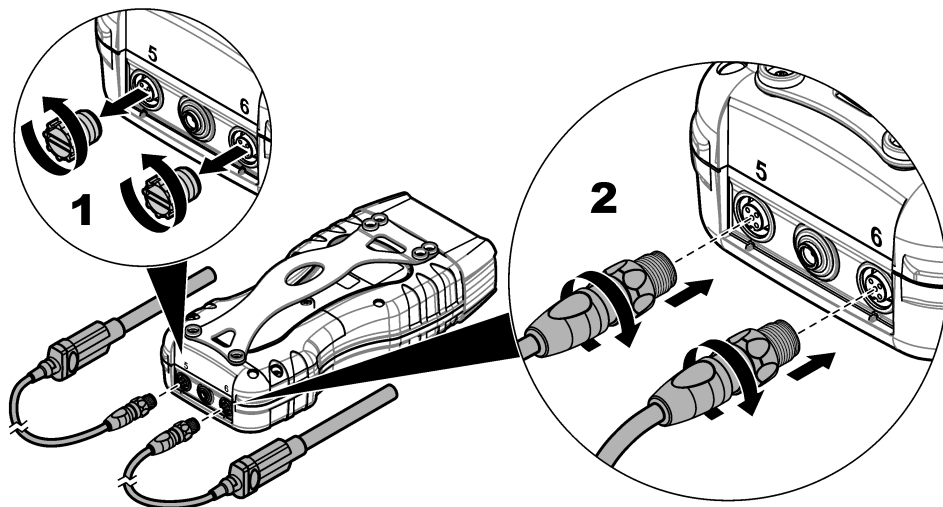

Complete probe measurements

Do the procedure that follows to complete a measurement with probe(s). Refer to [Figure 9](#). Multiple Chemkey measurements can be completed at the same time. Refer to [Complete Chemkey measurements](#) on page 11.

1. Calibrate the probes before initial use. Refer to [Calibrate the probe](#) on page 14.
Note: For the best accuracy, calibrate the probes daily.
2. Set the date and time in the meter before the probe is attached. Refer to [Change the date and time](#) on page 10.
The probe must have the correct service-life time stamp.
3. If complete traceability is necessary, enter a site ID and operator ID before measurement. Refer to [Use an operator ID](#) on page 10 and [Use a site ID](#) on page 10.
4. Remove the probe connector port caps and attach the probe(s). Refer to [Figure 8](#) on page 13 for the probe connection.
Note: Do not discard the probe connector port caps. Install the probe connector port caps again when no probe is connected.
5. Rinse the sample flasks with sample.
6. Fill the sample flask with sample so that the sensor is fully in the sample.
7. Put the probe(s) into the probe sample flasks and push **Read** if the measurement mode is set to **Press to Read**. Refer to the probe documentation for more information.
8. The measurement values are shown on the display.

Figure 9 Sample measurement

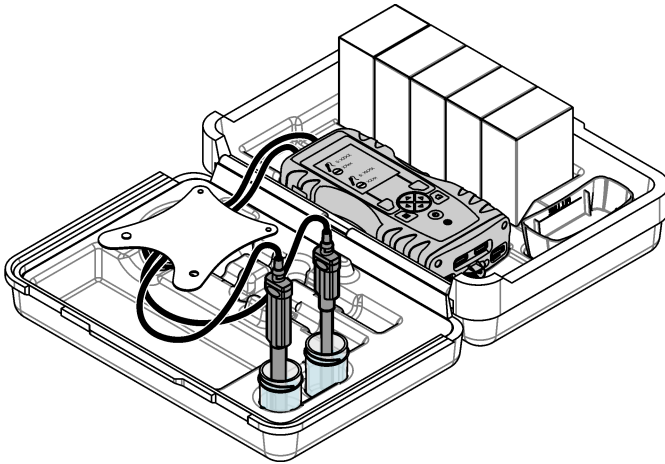

Calibration

⚠ CAUTION



Chemical exposure hazard. Obey laboratory safety procedures and wear all of the personal protective equipment appropriate to the chemicals that are handled. Refer to the current safety data sheets (MSDS/SDS) for safety protocols.

Calibrate the probe

Each probe uses a different type of calibration solution. Make sure to calibrate the probes frequently to maintain the highest level of accuracy. The meter will show the calibration status. If the calibration is not correct, the calibration icon with the question mark  shows until the probe is calibrated correctly. When the calibration is correct, the calibration icon with the green checkmark shows. For step-by-step instructions, refer to the documents that are included with each probe. Refer to [Select the probe settings](#) on page 18 for the calibration settings.

1. Connect a probe.
2. Push **Main Menu>Calibrate** to start a calibration.
3. Select the applicable probe if more than one is connected to the instrument.
Note: *If only one probe is attached this step does not show.*
4. Complete the instructions shown on the display to calibrate the probe.
Note: *For an ISE probe, push the RIGHT arrow to go to the next calibration standard as necessary. Measure standards from low concentration to high concentration.*
5. If necessary, do a verification. Refer to [Probe verification](#) on page 15.

Factory calibration

The manufacturer recommends that a full factory calibration be completed annually to make sure that the system operates as intended. Please contact the Hach Service Center serving your location.

Calibrate the meter for a specific Chemkey parameter

Each Chemkey uses different calibration setups. Refer to [Select the Chemkey settings](#) on page 17 for the calibration settings.

1. Push the applicable Chemkey(s) slowly, in one movement, into the slot(s) 1 to 4.
2. Push **Main Menu>Calibrate** to start a calibration.
3. Select the applicable Chemkey.
4. Enter the applicable standard adjust value.
5. Complete the instructions shown on the display to calibrate the Chemkey.
6. If necessary, do a verification. Refer to [Chemkey verification](#) on page 15.

Probe verification

1. Push **Main Menu>Verification** to start a verification.
2. Select the applicable device.
3. Complete the instructions shown on the display to do the verification.

*Note: To change the standard that is used for verification, push **Main Menu>Settings>Probe>[Select Probe]>Verification Options>Standard**.*

Chemkey verification

There are two options to complete a Chemkey verification. Use a parameter-specific Chemkey or a system verification Chemkey for the verification. Refer to [Replacement parts and accessories](#) on page 32.

• Parameter-specific Chemkey:

1. Push the parameter specific Chemkey slowly, in one movement, into the slot(s) 1 to 4.
2. Then, push **Main Menu>Verification** to start the verification.
3. Complete the menu guided process.

• System verification Chemkey:

1. Push **Main Menu>Verification** to start a verification.
2. Then, push the system verification Chemkey slowly, in one movement, into the first slot.
3. Complete the menu guided process.

Data log

The data log shows all saved measurements.

1. Push **Main Menu>Data Log**.
2. Select an option.

Option	Description
All Logs by Date	Shows sample measurement results: The probe name, probe serial number, value, unit, temperature, time, date, notes, operator ID, site ID and calibration details. The last measurement shows on the display. Push the LEFT arrow to look at the previous measurements.
Current Cal on Probe	Shows the calibration details for the most recent calibration. If the probe has not been calibrated by the user, the factory calibration data is shown.
Cal History on Probe	Shows a list of the times when the probe was calibrated. Select a date and time to view a summary of the calibration data.
Delete Data Log	Erases all data of the meter at once. The device data will be kept.

Import data to Excel

▲ WARNING



Electrical shock hazard. Externally connected equipment must have an applicable country safety standard assessment.

The meter stores the data log in an XML format. The site ID, sequence, date and time, parameter, measured value, units, operator ID, slot #, Chemkey lot code and the meter serial number can be stored in an Excel spreadsheet.

1. Set the meter power to on.
2. Connect the meter with the USB cable to the computer. The meter shows as a drive "Hach Portable Parallel Analysis" on the computer.
3. Open the "DataTemplate" folder from the drive.
4. Open the "LogTemplate.xlsx" file.
5. Right click on the cell "A2" and select XML>Import.
6. Select all log files from the "Data" folder from the "Hach Portable Parallel Analysis" drive.
7. Click **Import**.
The data log is shown in the Excel spreadsheet.
8. Save the file to the computer or to a USB flash drive if necessary.
9. Safely remove the meter from the computer. Click on the icon with the green arrow "Safely Remove Hardware and Eject Media" in the task bar.
Note: Some icons can be found under "Show hidden icons" in the task bar.
10. Disconnect the USB cable from the meter.

Look at data in a web browser

To look at the data log in a web browser, do the steps that follow. The site ID, sequence, date and time, parameter, measured value, units, operator ID, slot #, Chemkey lot code and the meter serial number are shown in the selected web browser.

1. Set the meter power to on.
2. Connect the meter with the USB cable to the computer. The meter shows as a drive "Hach Portable Parallel Analysis" on the computer.
3. Open the "Data" folder from the drive.
4. Open a data log file.
 - Open the "LogNN.XML" (NN = digits from 0 to 9) in any browser.
 - From the web browser, click **File>Open menu** and browse to the "Data" folder.
5. Save the file to the computer or to a USB flash drive if necessary.
6. Safely remove the meter from the computer. Click on the icon with the green arrow "Safely Remove Hardware and Eject Media" in the task bar.
Note: Some icons can be found under "Show hidden icons" in the task bar.
7. Disconnect the USB cable from the meter.

Advanced operation

Configure the meter

Select more options to configure the meter.

1. Push **Main Menu>Settings>Meter.**
2. Select an option.

Option	Description
Date & Time	Set the date and time. Refer to Change the date and time on page 10.
Display	Adjust the brightness and the contrast of the display. The brightest setting is 100 and the darkest setting is 0 (default: 75). The contrast settings are from 100 to 0 (default: 75).
Sounds	Set the sounds for key push, sample acquisition, stability alert, test complete, error/warning, low battery and charge complete.
Volume	Adjust the sound volume for the selected sound options from 0 to 100 (default: 100).
Auto-Shutoff Timer	To maximize battery life, set a time period after which the meter will automatically set the power to off if no key is pushed (1, 2, 5, 10 (default), 30 minutes, 1 hour, 2 hours). The auto-shutoff timer is disabled when the AC Adapter is connected to the meter.
Backlight Power	Set a time period after which the backlight will automatically power off if no key is pushed (1, 2, 5 (default), 10, 30 minutes, 1, hour or never).
Temperature Units	Select the degrees Celsius (default) or Fahrenheit.
USB Device Class	Select Mass Storage (default) or Communications. Mass Storage — The meter becomes a drive on the computer. Files can be moved from the meter to the PC or from the PC to the meter. Communications —The meter becomes a virtual serial device and lets the PC send commands to the meter. Contact technical support.
Upgrade Software	Select to upgrade the meter software. Refer to Upgrade the meter software on page 27.
Restart	Set the meter power to off and then to on again. Only use this function when the meter does not operate correctly. Note: <i>If the meter does not respond to any key pushes, push and hold the power key for 15 seconds to restart the meter. Data can get lost when the meter restarts.</i>
Restore Defaults	Change all settings back to the factory defaults.

Select the Chemkey settings

Every Chemkey has different advanced options from which to select.

1. Push **Main Menu>Settings>Chemkey.**
2. To record the measurement by parameter or chemical form, select **Display Label**.
Note: *When the chemical form is selected, more measurements can show on the screen without scrolling up or down.*
3. Select the applicable parameter.
4. Select an option.

Option	Description
Chemical Form	Select the alternate chemical form.
Calibration method	Select Factory or Standard Adjust (default) calibration methods. Factory —Use the original factory calibration. Standard Adjust —Complete a test on a known standard at a concentration near the top of the test range. Use this function to adjust the result to align the standard concentration.
Standard Adjust Value	Change the default value that is used for the standard adjust.
Verification Standard	Change the verification standard and enter a new standard value.

5. To change all Chemkey settings back to the default values, select **Restore Chemkey Defaults**.

Select the probe settings

Each probe has different advanced options from which to select.

Note: It is not necessary to connect the probes to select the probe settings. The probe settings are kept on the instrument.

1. Push **Main Menu>Settings>Probe**.
2. Select an option.



Option	Description
Measurement Mode	Select Press to Read (default) or Continuous . Press to Read —Push Read to complete one probe measurement only. Continuous —The current measurement value is shown continuously. Push Store for data storage.
Display Label	Select the Parameter Name (default) or the Probe Type to show on the display.
pH Options	Select Measurement , Calibration , Verification or Restore options. Refer to Select the pH options on page 18.
Conductivity Options	Select Measurement , Calibration , Verification or Restore options. Refer to Select the conductivity options on page 19.
LDO Options	Select Measurement , Calibration or Restore options. Refer to Select the LDO options on page 20.
Fluoride Options	Select Measurement , Calibration , Verification or Restore options. Refer to Select the fluoride options on page 21.
Nitrate Options	Select Measurement , Calibration , Verification or Restore options. Refer to Select the nitrate options on page 22.
Chloride Options	Select Measurement , Calibration , Verification or Restore options. Refer to Select the chloride options on page 22.
Sodium Options	Select Measurement , Calibration , Verification or Restore options. Refer to Select the sodium options on page 23.
Ammonium Options	Select Measurement , Calibration , Verification or Restore options. Refer to Select the ammonium options on page 24.
ORP Options	Select Measurement , Calibration , Verification or Restore options. Refer to Select the ORP options on page 25.

Select the pH options

Select more options for a pH probe.

1. Push **Main Menu>Settings>Probe>pH Options**.
2. Select an option.

Option	Description
Measurement Options	Select the display configuration, resolution and the manual temperature correction. Display Configuration —Select the parameters and the sequence the parameters show on the display. To change the sequence or set a parameter to not show on the display, push the UP or DOWN arrow to select the parameter, push the RIGHT arrow to select the parameter, then push the UP or DOWN arrow to move the parameter. Resolution —Select the applicable resolution: 0.1 pH – Fast, 0.01 pH – Fast (default), 0.01 pH – Medium, 0.01 pH – Slow or 0.001 pH - Slow. Manual Temp Correction —Apply only to probes without an automatic temperature compensation. Enter the necessary temperature value. Range: -10 to 110 °C (14 to 230 °F)

Option	Description
Calibration Options	Select the buffer set, slope limit and calibration frequency. Buffer Set —Select the applicable custom buffer set from the list. Slope Limit —Sets the slope limit. The slope (calibration curve) must fall within set limits for successful calibration. Cal Frequency —Select the necessary calibration frequency: Off (default), 2, 4, 8 hours, 1, 5 or 7 days. After the amount of time selected occurs (e.g., 8 hours), the calibration icon with the question mark  shows on the display until the probe is calibrated again or the Cal Frequency setting is changed.
Verification Options	Select the standard, acceptance criteria and failure invalidates calibration setting. Standard —Select the applicable standard to use for calibration verification from the list. Acceptance Criteria —Enter the range for satisfactory measurements. Example: If the acceptance criteria is 0.1 pH and the measured standard is 7 pH, then the acceptable range will be 6.9 to 7.1 pH. Failure Invalidates Cal —If "Yes" is selected and a probe verification fails, the calibration icon with the question mark  shows on the display until the probe is calibrated again, the meter power is set to off or the probe is disconnected. If "No" is selected, this function is disabled. Refer to Figure 4 on page 8 and Figure 5 on page 9.
Restore Defaults	Restore the settings for the selected probe type to the default settings.

Select the conductivity options

Select more options for a conductivity probe.

1. Push **Main Menu>Settings>Probe>Conductivity Options**.
2. Select an option.

Option	Description
Measurement Options	Select the display configuration, measurement units, salinity units, temperature correction, reference temperature and TDS information. Display Configuration —Select the parameters and the sequence the parameters show on the display. To change the sequence or set a parameter to not show on the display, push the UP or DOWN arrow to select the parameter, push the RIGHT arrow to select the parameter, then push the UP or DOWN arrow to move the parameter. Units —Select Auto (default), $\mu\text{S}/\text{cm}$ or mS/cm . Salinity Units —Selects the units for salinity (‰ (default), ppt (parts per thousand), g/kg or <unitless>). The units selected do not change the value shown. Temperature Correction —Select Correction Off, Linear, NaCl-Nonlinear (default) or Natural Water. Temp Correction Factor —Enabled when the temperature correction is set to Linear. Adjusts the result by a percentage for each degree Celcius that the temperature of the sample is different than the reference temperature. For example, if the temperature of the sample is $-2\text{ }^{\circ}\text{C}$ less than the reference temperature, the measured value is $10\text{ mS}/\text{cm}$ and the temperature correction factor is 2%, then the result shown is: $10\text{ mS}/\text{cm} - ((2 \times .02) \times 10\text{ mS}/\text{cm}) = 9.6\text{ mS}/\text{cm}$. Reference Temperature —Select $20\text{ }^{\circ}\text{C}$ or $25\text{ }^{\circ}\text{C}$ for the reference temperature. TDS Form —Select NaCl or Custom. TDS Factor —Shows only when the TDS Form is set to Custom and TDS is set to show on the display. To determine the conversion factor for a specific solution of a known TDS value, measure the conductivity of the solution and divide the mg/L TDS value by the conductivity value reported. For example, a solution of a known TDS value of 64 g/L and the measured conductivity value of $100\text{ mS}/\text{cm}$ has a conversion factor of $64 \div 100$ or 0.64. A common factor for high-salinity samples is 0.64.
Calibration Options	Standard —Select the applicable standard calibration unit.

Option	Description
Verification Options	Select the standard, acceptance criteria and failure invalidates calibration setting. Standard —Select the applicable standard to use for calibration verification from the list. Acceptance Criteria —Enter the range for satisfactory measurements. Example: If the acceptance criteria is 0.1 pH and the measured standard is 7 pH, then the acceptable range will be 6.9 to 7.1 pH. Failure Invalidates Cal —If "Yes" is selected and a probe verification fails, the calibration icon with the question mark  shows on the display until the probe is calibrated again, the meter power is set to off or the probe is disconnected. If "No" is selected, this function is disabled. Refer to Figure 4 on page 8 and Figure 5 on page 9.
Restore Defaults	Restore the settings for the selected probe type to the default settings.

Select the LDO options

Select more options for the LDO probe.

1. Push **Main Menu>Settings>Probe>LDO Options**.
2. Select an option.

Option	Description
Measurement Options	Select the display configuration, the resolution or the manual temperature correction. Display Configuration —Select the parameters that show on the display. Resolution —Select the applicable resolution: Fast - (0.35 mg/L)/min, Medium - (0.15 mg/L)/min (default) or Slow - (0.05 mg/L)/min. Pressure units —Select the applicable pressure unit: hPa (default), mBar, inHg or mmHg. Sal Correction Mode —Salinity lowers the solubility of dissolved oxygen in water. To correct for salinity in the sample, select Manual or Auto. When Auto is selected, the connected conductivity probe provides the salinity value when put in the sample. When Manual is selected, enter the salinity value of the sample in the Sal Correction Factor setting. Sal Correction Factor — Shows only when the Sal Correction Mode is set to Manual. Refer to Select the salinity correction factor on page 20 to select the value.
Calibration Options	Set the calibration method and enter the standard value. Calibration method —Select the applicable user calibration or factory calibration from the list. Standard —Edit the applicable value for the standard. Range: 2.000 to 20.000 mg/L
Restore Defaults	Restore the settings for the selected probe type to the default settings.

Select the salinity correction factor

1. Use a conductivity meter to measure the conductivity of the sample in mS/cm at a reference temperature of 20 °C (68 °F).
2. Use [Table 1](#) to estimate the salinity correction factor in parts per thousand (‰) saturation.

Table 1 Salinity saturation (‰) per conductivity value (mS/cm)

mS/cm	‰	mS/cm	‰	mS/cm	‰	mS/cm	‰
5	3	16	10	27	18	38	27
6	4	17	11	28	19	39	28
7	4	18	12	29	20	40	29
8	5	19	13	30	21	42	30
9	6	20	13	31	22	44	32
10	6	21	14	32	22	46	33
11	7	22	15	33	23	48	35
12	8	23	15	34	24	50	37
13	8	24	17	35	25	52	38
14	9	25	17	36	25	54	40
15	10	26	18	37	26		

Select the fluoride options

Select more options for a fluoride probe.

1. Push **Main Menu>Settings>Probe>Fluoride Options**.
2. Select an option.



Option	Description
Measurement Options	<p>Select the display configuration, digits of precision, measurement units, auto stabilization and stability criteria. Display Configuration—Select the parameters and the sequence the parameters show on the display. To change the sequence or set a parameter to not show on the display, push the UP or DOWN arrow to select the parameter, push the RIGHT arrow to select the parameter, then push the UP or DOWN arrow to move the parameter. Digits of Precision—Sets the significant digits shown—2, 3 (default) or 4. Units—Sets the preferred unit for measurements—mg/L (default), µg/L, %, ppm or ppb. Auto Stabilization—Sets auto stabilization—on (default) or off. The default stability drift rate is 1.0 mV/min. Stability Criteria—When Auto Stabilization is off, sets the stability criteria—0.1 to 9.9 mV/min.</p> <ul style="list-style-type: none"> • Lower stability criteria will require longer stabilization times, but the measurement will be more precise. • Higher stability criteria will require shorter stabilization times, but the measurements may be less precise.
Calibration Options	<p>Select the calibration frequency and slope limit. Cal Frequency—Select the necessary calibration frequency: Off (default), 2, 4, 8 hours, 1, 5 or 7 days. After the amount of time selected occurs (e.g., 8 hours), the calibration icon with the question mark  shows on the display until the probe is calibrated again or the Cal Frequency setting is changed. Slope Limit—Sets the slope limit. The slope (calibration curve) must fall within set limits for successful calibration.</p>

Option	Description
Verification Options	Select the standard, acceptance criteria and failure invalidates calibration setting. Standard —Select the applicable standard to use for calibration verification from the list. Acceptance Criteria —Enter the range for satisfactory measurements. Example: If the acceptance criteria is 1.0 % and the measured standard is 70 mg/L, then the acceptable range will be 69.3 to 70.7 mg/L. Failure Invalidates Cal —If "Yes" is selected and a probe verification fails, the calibration icon with the question mark  shows on the display until the probe is calibrated again, the meter power is set to off or the probe is disconnected. If "No" is selected, this function is disabled. Refer to Figure 4 on page 8 and Figure 5 on page 9.
Restore Defaults	Restore the settings for the selected probe type to the default settings.

Select the nitrate options

Select more options for a nitrate probe.



1. Push **Main Menu>Settings>Probe>Nitrate Options**.
2. Select an option.

Option	Description
Measurement Options	Select the display configuration, chemical form, digits of precision, measurement units, auto stabilization or stability criteria. Display Configuration —Select the parameters and the sequence the parameters show on the display. To change the sequence or set a parameter to not show on the display, push the UP or DOWN arrow to select the parameter, push the RIGHT arrow to select the parameter, then push the UP or DOWN arrow to move the parameter. Chemical Form —Sets the chemical form in which the concentration shows—NO ₃ ⁻ or NO ₃ ⁻ -N. Digits of Precision —Sets the significant digits shown—2, 3 (default) or 4. Units —Sets the preferred unit for measurements—mg/L (default), µg/L, %, ppm or ppb. Auto Stabilization —Sets auto stabilization—on (default) or off. The default stability drift rate is 1.0 mV/min. Stability Criteria —When Auto Stabilization is off, sets the stability criteria—0.1 to 9.9 mV/min. <ul style="list-style-type: none"> • Lower stability criteria will require longer stabilization times, but the measurement will be more precise. • Higher stability criteria will require shorter stabilization times, but the measurements may be less precise.
Calibration Options	Select the calibration frequency and slope limit. Cal Frequency —Select the necessary calibration frequency: Off (default), 2, 4, 8 hours, 1, 5 or 7 days. After the amount of time selected occurs (e.g., 8 hours), the calibration icon with the question mark  shows on the display until the probe is calibrated again or the Cal Frequency setting is changed. Slope Limit —Sets the slope limit. The slope (calibration curve) must fall within set limits for successful calibration.
Verification Options	Select the standard, acceptance criteria and failure invalidates calibration setting. Standard —Select the applicable standard to use for calibration verification from the list. Acceptance Criteria —Enter the range for satisfactory measurements. Example: If the acceptance criteria is 1.0 % and the measured standard is 70 mg/L, then the acceptable range will be 69.3 to 70.7 mg/L. Failure Invalidates Cal —If "Yes" is selected and a probe verification fails, the calibration icon with the question mark  shows on the display until the probe is calibrated again, the meter power is set to off or the probe is disconnected. If "No" is selected, this function is disabled. Refer to Figure 4 on page 8 and Figure 5 on page 9.
Restore Defaults	Restore the settings for the selected probe type to the default settings.

Select the chloride options

Select more options for a chloride probe.

1. Push **Main Menu>Settings>Probe>Chloride Options**.
2. Select an option.



Option	Description
Measurement Options	<p>Select the display configuration, digits of precision, measurement units, auto stabilization and stability criteria. Display Configuration—Select the parameters and the sequence the parameters show on the display. To change the sequence or set a parameter to not show on the display, push the UP or DOWN arrow to select the parameter, push the RIGHT arrow to select the parameter, then push the UP or DOWN arrow to move the parameter. Digits of Precision—Sets the significant digits shown—2, 3 (default) or 4. Units—Sets the preferred unit for measurements—mg/L (default), µg/L, %, ppm or ppb. Auto Stabilization—Sets auto stabilization—on (default) or off. The default stability drift rate is 1.0 mV/min. Stability Criteria—When Auto Stabilization is off, sets the stability criteria—0.1 to 9.9 mV/min.</p> <ul style="list-style-type: none"> • Lower stability criteria will require longer stabilization times, but the measurement will be more precise. • Higher stability criteria will require shorter stabilization times, but the measurements may be less precise.
Calibration Options	<p>Select the calibration frequency and slope limit. Cal Frequency—Select the necessary calibration frequency: Off (default), 2, 4, 8 hours, 1, 5 or 7 days. After the amount of time selected occurs (e.g., 8 hours), the calibration icon with the question mark  shows on the display until the probe is calibrated again or the Cal Frequency setting is changed. Slope Limit—Sets the slope limit. The slope (calibration curve) must fall within set limits for successful calibration.</p>
Verification Options	<p>Select the standard, acceptance criteria and failure invalidates calibration setting. Standard—Select the applicable standard to use for calibration verification from the list. Acceptance Criteria—Enter the range for satisfactory measurements. Example: If the acceptance criteria is 1.0 % and the measured standard is 70 mg/L, then the acceptable range will be 69.3 to 70.7 mg/L. Failure Invalidates Cal—If "Yes" is selected and a probe verification fails, the calibration icon with the question mark  shows on the display until the probe is calibrated again, the meter power is set to off or the probe is disconnected. If "No" is selected, this function is disabled. Refer to Figure 4 on page 8 and Figure 5 on page 9.</p>
Restore Defaults	Restore the settings for the selected probe type to the default settings.

Select the sodium options

Select more options for a sodium probe.

1. Push **Main Menu>Settings>Probe>Sodium Options**.
2. Select an option.



Option	Description
Measurement Options	<p>Select the display configuration, digits of precision, measurement units, auto stabilization and stability criteria. Display Configuration—Select the parameters and the sequence the parameters show on the display. To change the sequence or set a parameter to not show on the display, push the UP or DOWN arrow to select the parameter, push the RIGHT arrow to select the parameter, then push the UP or DOWN arrow to move the parameter. Digits of Precision—Sets the significant digits shown—2, 3 (default) or 4. Units—Sets the preferred unit for measurements—mg/L (default), µg/L, %, ppm or ppb. Auto Stabilization—Sets auto stabilization—on (default) or off. The default stability drift rate is 1.0 mV/min. Stability Criteria—When Auto Stabilization is off, sets the stability criteria—0.1 to 9.9 mV/min.</p> <ul style="list-style-type: none"> • Lower stability criteria will require longer stabilization times, but the measurement will be more precise. • Higher stability criteria will require shorter stabilization times, but the measurements may be less precise.

Option	Description
Calibration Options	Select the calibration frequency and slope limit. Cal Frequency —Select the necessary calibration frequency: Off (default), 2, 4, 8 hours, 1, 5 or 7 days. After the amount of time selected occurs (e.g., 8 hours), the calibration icon with the question mark  shows on the display until the probe is calibrated again or the Cal Frequency setting is changed. Slope Limit —Sets the slope limit. The slope (calibration curve) must fall within set limits for successful calibration.
Verification Options	Select the standard, acceptance criteria and failure invalidates calibration setting. Standard —Select the applicable standard to use for calibration verification from the list. Acceptance Criteria —Enter the range for satisfactory measurements. Example: If the acceptance criteria is 1.0 % and the measured standard is 70 mg/L, then the acceptable range will be 69.3 to 70.7 mg/L. Failure Invalidates Cal —If "Yes" is selected and a probe verification fails, the calibration icon with the question mark  shows on the display until the probe is calibrated again, the meter power is set to off or the probe is disconnected. If "No" is selected, this function is disabled. Refer to Figure 4 on page 8 and Figure 5 on page 9.
Restore Defaults	Restore the settings for the selected probe type to the default settings.

Select the ammonium options

Select more options for an ammonium probe.



1. Push **Main Menu>Settings>Probe>Ammonium Options**.
2. Select an option.

Option	Description
Measurement Options	Select the display configuration, chemical form, digits of precision, measurement units, auto stabilization or stability criteria. Display Configuration —Select the parameters and the sequence the parameters show on the display. To change the sequence or set a parameter to not show on the display, push the UP or DOWN arrow to select the parameter, push the RIGHT arrow to select the parameter, then push the UP or DOWN arrow to move the parameter. Chemical Form —Sets the chemical form in which the concentration shows— NH_4^+ , $\text{NH}_4^+\text{-NH}_3$ or $\text{NH}_4^+\text{-N}$. Digits of Precision —Sets the significant digits shown—2, 3 (default) or 4. Units —Sets the preferred unit for measurements—mg/L (default), $\mu\text{g/L}$, %, ppm or ppb. Auto Stabilization —Sets auto stabilization—on (default) or off. The default stability drift rate is 1.0 mV/min. Stability Criteria —When Auto Stabilization is off, sets the stability criteria—0.1 to 9.9 mV/min. <ul style="list-style-type: none"> • Lower stability criteria will require longer stabilization times, but the measurement will be more precise. • Higher stability criteria will require shorter stabilization times, but the measurements may be less precise.
Calibration Options	Select the calibration frequency and slope limit. Cal Frequency —Select the necessary calibration frequency: Off (default), 2, 4, 8 hours, 1, 5 or 7 days. After the amount of time selected occurs (e.g., 8 hours), the calibration icon with the question mark  shows on the display until the probe is calibrated again or the Cal Frequency setting is changed. Slope Limit —Sets the slope limit. The slope (calibration curve) must fall within set limits for successful calibration.
Verification Options	Select the standard, acceptance criteria and failure invalidates calibration setting. Standard —Select the applicable standard to use for calibration verification from the list. Acceptance Criteria —Enter the range for satisfactory measurements. Example: If the acceptance criteria is 1.0 % and the measured standard is 70 mg/L, then the acceptable range will be 69.3 to 70.7 mg/L. Failure Invalidates Cal —If "Yes" is selected and a probe verification fails, the calibration icon with the question mark  shows on the display until the probe is calibrated again, the meter power is set to off or the probe is disconnected. If "No" is selected, this function is disabled. Refer to Figure 4 on page 8 and Figure 5 on page 9.
Restore Defaults	Restore the settings for the selected probe type to the default settings.

Select the ORP options

Select more options for an ORP probe.

1. Push **Main Menu>Settings>Probe>ORP Options**.
2. Select an option.

Option	Description
Measurement Options	Display Configuration —Select the parameters and the sequence the parameters show on the display. To change the sequence or set a parameter to not show on the display, push the UP or DOWN arrow to select the parameter, push the RIGHT arrow to select the parameter, then push the UP or DOWN arrow to move the parameter. Response Time —Set the response time (Fast (2 mV/minute), Medium (1 mV/minute) or Slow (0.5 mV/minute). The response time affects the speed of the measurement by adjusting the stabilization criteria.
Calibration Options	Standard —Select the applicable standard to use for calibration from the list. Offset Limit —Sets the offset limits (± 1 mV to 250 mV). The calibration measurement must fall within the offset limit for a successful calibration. Cal Frequency —Select the necessary calibration frequency: Off (default), 2, 4, 8 hours, 1, 5 or 7 days. After the amount of time selected occurs (e.g., 8 hours), the calibration icon with the question mark  shows on the display until the probe is calibrated again or the Cal Frequency setting is changed. Standard Value —Selects the value of the standard to use for calibration (-1200 to 1200 mV). This option only shows when Custom is selected in the Standard setting.
Verification Options	Select the standard, acceptance criteria and failure invalidates calibration setting. Standard —Select the applicable standard to use for calibration verification from the list. Acceptance Criteria —Enter the range for satisfactory measurements. Example: If the acceptance criteria is 1.0 % and the measured standard is 70 mg/L, then the acceptable range will be 69.3 to 70.7 mg/L. Failure Invalidates Cal —If "Yes" is selected and a probe verification fails, the calibration icon with the question mark  shows on the display until the probe is calibrated again, the meter power is set to off or the probe is disconnected. If "No" is selected, this function is disabled. Refer to Figure 4 on page 8 and Figure 5 on page 9. Standard Value —Selects the value of the standard to use for calibration verification (-1200 to 1200 mV). This option only shows when Custom is selected in the Standard setting.
Restore Defaults	Restore the settings for the selected probe type to the default settings.

Add operators, notes, sites and routes

Add operators, notes, sites and routes to the meter with the web application "tool.htm".

1. Set the meter power to on.
2. Connect the meter with the USB cable to the computer. The meter shows as a drive "Hach Portable Parallel Analysis" on the computer.
3. Open the "tools.htm" file. The **Start** page of the program "SL/1000 PPA Tool Set" opens in the standard internet browser.
4. Click on **Browse** (Internet Explorer and Firefox) or **Choose File** (Chrome) to select the WebConfigCache.zip file from the "Hach Portable Parallel Analysis" drive.
5. Click **Open** to open the "Manage Site List" web page.
6. Click **Operators, Notes, Sites or Routes** from the main menu tab.

Option	Description
Operators	Add new operator. An operator ID is associated with the person who completes the water test. The current operator ID is logged with each measurement.
Notes	Add notes to record special information about a measurement. Add this information to an event log.

Option	Description
Sites	Add a new site. A site can be associated with a specific measurement sample, such as a location name or sampling point where the water test is taken. The current site ID is logged with each measurement. If applicable add the site ID to a specific route.
Routes	Add a route with an ordered list of site IDs. Enter a name for each route that is connected to the list of sites to be visited. The current route is logged with each measurement. Refer to Set up routes on page 26 for more detailed information.

7. Type the applicable name or information in the lower box and click **Add**.
8. Select one or more names or information and click **Up** or **Down** to change the order of the list.
9. Select one or more names or information and click **Delete** to erase the applicable name or information.
10. Click **Save** to save all information to the meter.
A Save File dialog prompt may open or the file is saved to the "Downloads" folder. If the file is saved in the "Downloads" folder, copy the downloaded WebConfigCache.zip file to the "Hach Portable Parallel Analysis" drive.
11. Confirm with OK to replace the "WebConfigCache.zip" on the "Hach Portable Parallel Analysis" drive.
Note: Make sure to keep the current name of the "WebConfigCache.zip" file.
12. Safely remove the meter from the computer. Click on the icon with the green arrow "Safely Remove Hardware and Eject Media" in the task bar.
Note: Some icons can be found under "Show hidden icons" in the task bar.
13. Disconnect the USB cable from the meter.
14. The new changes are available on the meter.

Set up routes

A route is an ordered list of sites that are associated with measurements for a particular sample or a location. Use the steps that follow to set up routes for daily management.

1. Select **Routes** from the main menu tab.
2. Add one or more routes names. Type the applicable names in the lower box and click **Add**.
3. Click **Edit** to add the applicable sites to the selected route.
4. To change the order of the list, highlight one or more names and click **Up** or **Down**.
To erase a site from the list, highlight one or more names and click **Remove**.
Note: The site ID will remain in the master site ID list, even if a route is removed.
5. Click **Save** to save all information to the meter.
A Save File dialog prompt may open or the file is saved to the "Downloads" folder. If the file is saved in the "Downloads" folder, copy the downloaded WebConfigCache.zip file to the "Hach Portable Parallel Analysis" drive.
6. Confirm with OK to replace the "WebConfigCache.zip" on the "Hach Portable Parallel Analysis" drive.
Note: Make sure to keep the current name of the "WebConfigCache.zip" file.
7. Safely remove the meter from the computer. Click on the icon with the green arrow "Safely Remove Hardware and Eject Media" in the task bar.
Note: Some icons can be found under "Show hidden icons" in the task bar.
8. Disconnect the USB cable from the meter.
9. Push **Main Menu>Site ID>Mode>Route**.
10. Push **OK**.
11. Push **Routes** and select the applicable route.
12. Push the **HOME** key. The first site of the selected route is shown on the display.
13. Select the next site from the route list with the **RIGHT** and **LEFT** arrows.
The current route and site are logged with each measurement.

See the system information

The information menu shows more information about the meter, slots and probes. The probe information only shows when a probe is connected.

1. Push **Main Menu>Info**.
2. Select an option.

Option	Description
Meter	Show the meter name, the serial number, the boot version, the software version, the battery level and the available memory.
Slots	Select the applicable slot (1 to 4) to see the boot version, the software version and the serial number. If a Chemkey is in the selected slot, more information such as Chemkey name, expiration date, bar code and lot code are shown.
Probes	Select the applicable probe to see the boot version, the software version, the serial number and the first used date (YYYY-MM-DD). When an LDO probe is connected, the sensor lot code is shown.

Upgrade the meter software

Do the instructions that follow to upgrade the software on the meter. Find the firmware upgrade file on the manufacturer's website. Save the file from the website to the computer.

1. Connect the meter to AC power.
2. Select **Main Menu>Settings>Meter>USB Device Class>Mass Storage**.
3. Connect the meter with the USB cable to the computer.
The meter shows as a drive "Hach Portable Parallel Analysis" on the computer.
4. Open the "tools.htm" file. Click on the link to the software upgrade package.
5. Copy the upgrade file to "Hach Portable Parallel Analysis" drive.
6. Safely remove the meter from the computer. Click on the icon with the green arrow "Safely Remove Hardware and Eject Media" in the task bar.
Note: Some icons can be found under "Show hidden icons" in the task bar.
7. Select **Main Menu>Settings>Meter>Upgrade Software**.
8. Push **Continue**.
9. Push **Exit** when the update is done.

Maintenance

▲ WARNING



Multiple hazards. Only qualified personnel must conduct the tasks described in this section of the document.

▲ CAUTION



Chemical exposure hazard. Obey laboratory safety procedures and wear all of the personal protective equipment appropriate to the chemicals that are handled. Refer to the current safety data sheets (MSDS/SDS) for safety protocols.

▲ CAUTION



Chemical exposure hazard. Dispose of chemicals and wastes in accordance with local, regional and national regulations.

Clean spills

⚠ CAUTION



Chemical exposure hazard. Dispose of chemicals and wastes in accordance with local, regional and national regulations.

1. Obey all facility safety protocols for spill control.
2. Discard the waste according to applicable regulations.

Clean the instrument

Clean the exterior of the instrument with a moist cloth and a mild soap solution and then wipe the instrument dry as necessary.

Clean or replace parts

For some errors and warnings it is a requirement to clean the Chemkey slots, the optical windows, the barcode window, the sample detector or to replace the trays. Use isopropyl alcohol to clean the parts. Use water and a mild detergent to clean the light shield. Make sure to move the cotton tipped applicator in one direction only. Refer to [Figure 10](#) to remove the optics access cover, the light shield and the trays. Refer to [Figure 11](#) and [Figure 12](#) for the detailed cleaning procedure.

Items to collect: Cotton tipped applicator, isopropyl alcohol, water and a mild detergent

Figure 10 Parts removal and reassembly

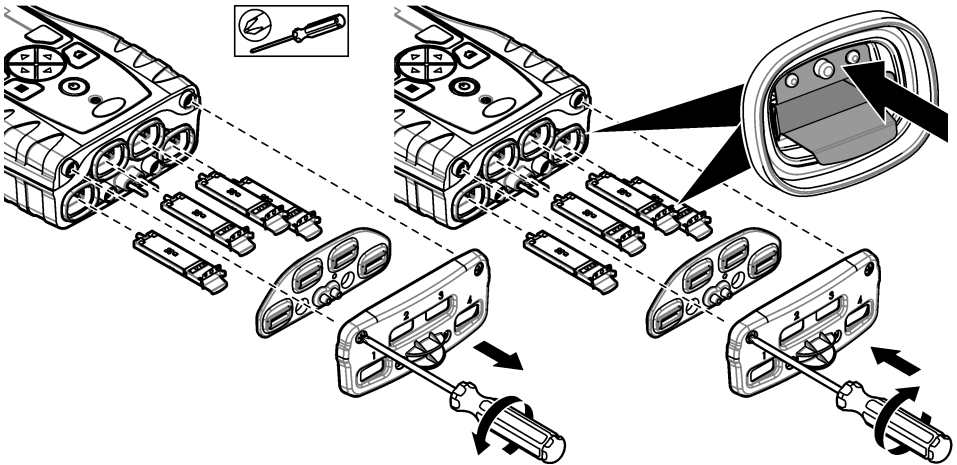
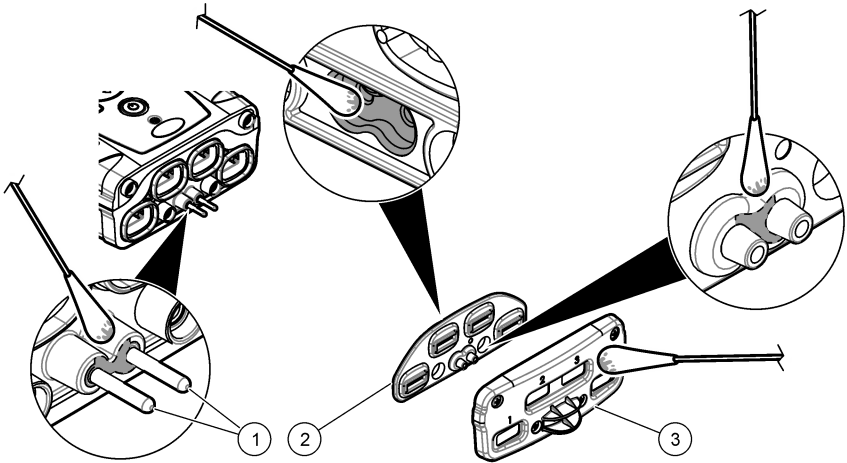
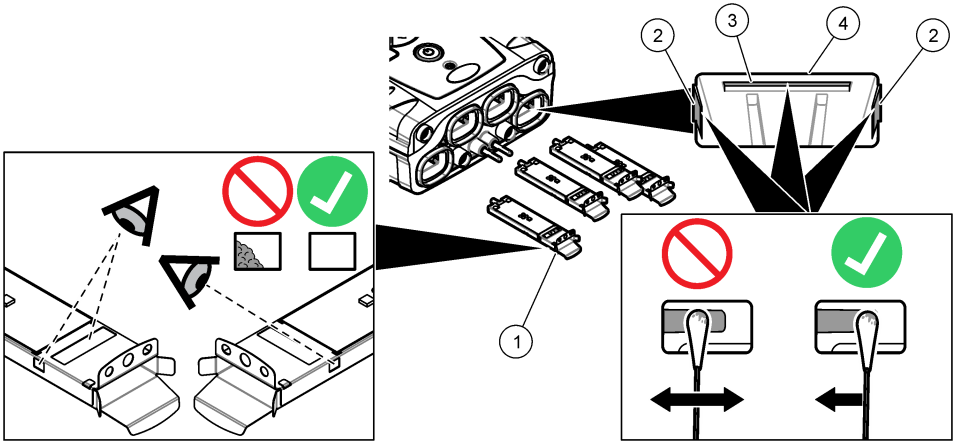

Figure 11 Clean sample detector, light shield and access cover



1 Sample detector	3 Optics access cover
2 Light shield	

Figure 12 Clean trays and Chemkey slots



1 Tray	3 Barcode window
2 Optical window	4 Chemkey slot

Charge or replace the battery

Charge the battery when the battery power level is low. Replace the battery when the battery does not hold a charge. Only use the specified battery supplied by the manufacturer. Refer to [Install the battery](#) on page 6 and [Replacement parts and accessories](#) on page 32.

Prepare for shipping

NOTICE

Potential instrument damage. Drain all water from the unit before shipment to prevent damage from freezing temperatures.

Contact technical support for instructions before the shipment to the manufacturer.

- Clean and decontaminate the instrument before shipping.
- Ship the instrument with the battery installed in the meter, but make sure that the battery is not connected to the connector.
- Disconnect the probes and remove the Chemkeys before shipping.
- Ship the instrument in the original packaging or ship the instrument in an alternative safe packaging.

Troubleshooting

Error/Warning	Possible cause	Solution
Barcode read error Please reinsert Chemkey(s)	Chemkey does not operate correctly. Chemkey is not installed correctly.	<ul style="list-style-type: none"> • Put the Chemkey into the slot again. • Use a new Chemkey. • Clean the barcode window. Refer to Figure 12 on page 29. • If the problem still occurs, contact technical support.
Sample aspirate error.	Chemkey does not operate correctly. Chemkey is not fully pushed into the slot.	Use a new Chemkey and make sure to push the Chemkey all of the way into the slot. If the problem still occurs, contact technical support.
Chemkey Leaked. Try another		
Chemkey expired		
Measurement Error (1–4)	A measurement error occurred in the specified slot.	
Parameter not supported	The parameter is not available in the installed instrument software.	Upgrade the instrument software. Search for "SL1000" on www.hach.com . Go to the Downloads>Software/Firmware section and follow the instructions on the website.
Used Chemkey— Replace	The Chemkey has already been used or there is water in the slot.	Use a new Chemkey. If the problem still occurs, dry out the slot and the instrument and try again. If the problem still occurs, contact technical support.
Tray leaked. Replace tray.	A problem with the measured tray occurred.	Replace the tray. Refer to Figure 10 on page 28. If the problem still occurs, contact technical support.
Heater Error Replace Tray	The tray does not operate correctly.	
Remove from sample.	The meter was put into the sample before the meter was ready.	Wait until the meter is ready to be put into the sample.
Sample removed too soon		Put another Chemkey into the slot. Wait until the meter is ready to be put into the sample.

Error/Warning	Possible cause	Solution
Too much time in sample	The Chemkeys were left in the sample too long. A measurement error occurred.	Remove the Chemkeys immediately when prompted.
	The sample detector pin area is dirty if the warning shows while the meter is not in the sample.	Clean the sample detector pin area. Refer to Clean or replace parts on page 28. If the problem still occurs, contact technical support.
Over Range	The concentration is more than the upper limit of the current method.	Dilute the sample and do the measurement again.
Under Range	The concentration is less than the lower limit of the current method.	—
Tray too cold.	The meter may be too cold to heat the tray or the heater is not operational.	Move the meter to a warmer ambient temperature and measure again. Replace the tray.
Tray too hot.	The meter is too hot to make a correct measurement.	Make sure to cool the meter or move the meter out of the warm ambient area.
Too much ambient light. Insert Chemkey in darker environment	The ambient light is too high to read the barcode.	Move the meter to a darker environment and put the Chemkey into the slot again.
Low Light. Clean Chemkey slot.	Chemkey does not operate correctly. Chemkey is not installed correctly.	<ul style="list-style-type: none"> Put the Chemkey into the slot in one push. Use a new Chemkey. Clean the Chemkey slot. Refer to Figure 12 on page 29. If the problem still occurs, contact technical support.
Instrument requires service.	Module failure.	Use the modules that operate correctly. Contact technical support to repair the defective module.
Sample not found.	<ul style="list-style-type: none"> The sample cup is not filled to the fill line. The sample conductivity is less than 2 $\mu\text{S}/\text{cm}$. 	<ul style="list-style-type: none"> Make sure that the sample cup is filled to the fill line. Make sure that the sample conductivity is more than 2 $\mu\text{S}/\text{cm}$. Clean the sample detector. Refer to Figure 11 on page 29. If the problem still occurs, contact technical support.

Do a diagnostic check

The diagnostic menu shows the information about the current versions of the meter and the option to format the memory card.

1. Push **Main Menu>Diagnostics**.
2. Select an option.

Option	Description
Disk Space	Show the disk space for the user memory and for the internal memory.
Config Versions	Show the configuration versions of the meter settings.

Option	Description
Method Versions	Show the method versions of the meter.
Format Memory	Erase all meter data. Note: All meter data (e.g., meter configuration, site IDs, operator IDs, routes, notes, templates and more) will be lost when Format Memory is completed.

Replacement parts and accessories

⚠ WARNING



Personal injury hazard. Use of non-approved parts may cause personal injury, damage to the instrument or equipment malfunction. The replacement parts in this section are approved by the manufacturer.

Note: Product and Article numbers may vary for some selling regions. Contact the appropriate distributor or refer to the company website for contact information.

Replacement parts

Description	Item no.
Battery	9094900
Battery door	9436600
Replacement nosecone (optics access cover)	9431700
Tray	9377700
Hand strap	9436700
Light shield, optics access cover	9432900
Power cable (US)	1801000
Power cable (EU)	YAA080
Power cable (UK)	XLH057
Power cable (CH)	XLH051
External power supply (without power cable)	8497000
Sample cup	9418100
Flask, 90 mL	8610400
Probe connector cap	5210000

Accessories

Description	Item no.
Chlorine verification Chemkey®	9427900
System verification Chemkey®	9436800
IntelliCAL™ LDO101 Standard Luminescent/Optical Dissolved Oxygen (LDO) Probe, 1-Meter Cable	LDO10101
IntelliCAL™ PHC201 Standard Gel Filled pH Electrode, 1 meter cable	PHC20101
IntelliCAL™ PHC281 pH Ultra Refillable pH Electrode, 1 meter cable	PHC28101
IntelliCAL™ CDC401 Standard Conductivity Probe, 1 meter cable	CDC40101
IntelliCAL™ ISEF121 Fluoride Ion Selective Electrode (ISE), 1 meter cable	ISEF12101

Accessories (continued)

Description	Item no.
IntelliCAL™ ISENO3181 Nitrate Ion Selective Electrode (ISE), 1 meter cable	ISENO318101
IntelliCAL™ ISECL181 Chloride Ion Selective Electrode (ISE), 1 meter cable	ISECL18101
Probe cable retainer	9422200
Car charger	9374200
USB cable	9070800
Cotton tipped applicator	2522905



HACH COMPANY World Headquarters

P.O. Box 389, Loveland, CO 80539-0389 U.S.A.
Tel. (970) 669-3050
(800) 227-4224 (U.S.A. only)
Fax (970) 669-2932
orders@hach.com
www.hach.com

HACH LANGE GMBH

Willstätterstraße 11
D-40549 Düsseldorf, Germany
Tel. +49 (0) 2 11 52 88-320
Fax +49 (0) 2 11 52 88-210
info-de@hach.com
www.de.hach.com

HACH LANGE Sàrl

6, route de Compois
1222 Vézenaz
SWITZERLAND
Tel. +41 22 594 6400
Fax +41 22 594 6499