



# INSTRUCTION SHEET

Hydraulic Clamping Kit for No.412 and No.618

A1870301, A1262301

## Overview

This kit is used to convert a standard No.412 and No.618 fusion machine to have hydraulic clamping.



## A1870301 618/T618 Hydraulic Clamping Kit

### A1870301 618/T618 Hydraulic Clamping Kit includes:

		Qty per
187030101	412/T412/618/T618 hyd clamping kit instruction sheet	1
MJL00062	F drill bit	1
MJL00063	5/16-18NC tap	1
MLN00112	11.5" X .19" Cable Tie	9
1801203	Hydraulic clamping upper jaw	2
1806302	Jaw clamp pad modification	4
1870701	Manifold mounting bracket	1
1870801	Fixed jaw clamp handle	1
1870901	Movable jaw clamp handle	1
MEB00150	2"b x 3"s x 3/4"r clamp cylinder	4
MAB00081	1/2-13nc'x1-1/4 lg hhcs	2
MAG00003	#10-24ncx1/4 lg socket set screw	4
MCF00002	1/2diax1-11/32 grip clv pin	4
MCH00001	1/8diax1lg cotter pin	4
MAN00001	#10-24ncx3/8 lg fhscs ss	8
MAB00003	1/4-20ncx3/4 lg hhcs	4
MBE00005	1/4 reg split lock washer	4
MAB00032	5/16-18ncx3/4 lg hhcs	4
MBE00006	5/16 reg split lock washer	4
1870401	Hydraulic clamping manifold assembly	1
1870501	412/T412/618/T618 hydraulic clamping plumbing schematic	1



# INSTRUCTION SHEET

Hydraulic Clamping Kit for No.412 and No.618

A1870301, A1262301

## A1262301 412/T412 Hydraulic Clamping Kit

### A1262301 412/T412 Hydraulic Clamping Kit includes:

		Qty per
187030101	412/T412/618/T618 hyd clamping kit instruction sheet	1
MJL00062	F drill bit	1
MJL00063	5/16-18NC tap	1
MLN00112	11.5" X .19" Cable Tie	9
1203305	Hydraulic clamping DIPS upper jaw	2
1262701	412 hydraulic clamping outer fixed jaw brace	1
1262601	No.412 hydraulic clamping clamp pad	4
1262501	No.412 hydraulic clamping manifold mounting bracket	1
1870801	Fixed jaw clamp handle	1
1870901	Movable jaw clamp handle	1
MEB00153	2"b x 3"s x 5/8"r clamp cylinder	4
MAB00081	1/2-13nc'x1-1/4 lg hhcs	2
MAG00003	#10-24ncx1/4 lg socket set screw	4
MCF00002	1/2diax1-11/32 grip clv pin	4
MCH00001	1/8diax1lg cotter pin	4
MAN00001	#10-24ncx3/8 lg fhscs ss	8
MAB00003	1/4-20ncx3/4 lg hhcs	4
MBE00005	1/4 reg split lock washer	4
MAB00032	5/16-18ncx3/4 lg hhcs	4
MBE00006	5/16 reg split lock washer	4
1870401	Hydraulic clamping manifold assembly	1
1870501	412/T412/618/T618 hydraulic clamping plumbing schematic	1
8163149	No.412 Label	1
MDL00242	Edge molding	8.5"

## Tool Required

### Tools Required:

- 3/32" Hex Key Wrench
- 1/8" Hex Key Wrench
- 1/4" Hex Key Wrench
- 3/16" Hex Key Wrench
- 7/16" Wrench
- 1/2" Wrench
- 9/16" Wrench
- 5/8" Wrench
- 11/16" Wrench
- 3/4" Wrench
- 13/16" Wrench
- 1" Wrench
- Wire Cutters
- Center Punch
- Electric Drill
- Hammer
- Teflon Tape
- Tapping Fluid
- Tap Wrench



# INSTRUCTION SHEET

Hydraulic Clamping Kit for No.412 and No.618

A1870301, A1262301

## Safety Alerts



This hazard alert sign appears in this manual. When you see this sign, carefully read what it says. **YOUR SAFETY IS AT STAKE.** You will see the hazard alert sign with these words: **DANGER**, **WARNING**, and **CAUTION**.



Indicates an imminently hazardous situation which, if not avoided, will result in death or serious injury.



Indicates a potentially hazardous situation which, if not avoided, could result in death or serious injury.



Indicates a hazardous situation which, if not avoided, may result in minor or moderate injury.

In this manual you should look for two other words: **NOTICE** and **IMPORTANT**.

**NOTICE:** can keep you from doing something that might damage the machine or someone's property. It may also be used to alert against unsafe practices.

**IMPORTANT:** can help you do a better job or make your job easier in some way.



## Read and Understand

Do not operate this equipment until you have carefully read, and understand the "Safety" and "Operation" sections of this manual, and all other equipment manuals that will be used with it.

Your safety and the safety of others depends upon care and judgment in the operation of this equipment. Follow all applicable federal, state, local, and industry specific regulations.

McElroy Manufacturing, Inc. cannot anticipate every possible circumstance that might involve a potential hazard. The warnings in this manual and on the machine are therefore not all inclusive. You must satisfy yourself that a procedure, tool, work method, or operating technique is safe for you and others. You should also ensure that the machine will not be damaged or made unsafe by the method of operation or maintenance you choose.

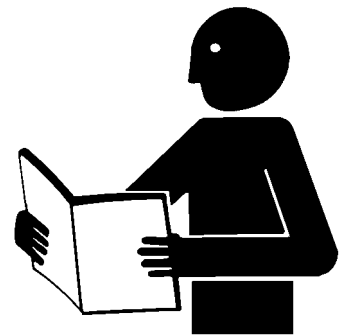

## General Safety

Safety is important. Report anything unusual that you notice during set up or operation.

**LISTEN** for thumps, bumps, rattles, squeals, air leaks, or unusual sounds.

**SMELL** odors like burning insulation, hot metal, burning rubber, hot oil, or natural gas.

**FEEL** any changes in the way the equipment operates.

**SEE** problems with wiring and cables, hydraulic connections, or other equipment.

**REPORT** anything you see, feel, smell, or hear that is different from what you expect, or that you think may be unsafe.





# INSTRUCTION SHEET

Hydraulic Clamping Kit for No.412 and No.618

A1870301, A1262301

## Wear Safety Equipment

Wear a hard hat, safety shoes, safety glasses, and other applicable personal protective equipment.

Remove jewelry and rings, and do not wear loose-fitting clothing or long hair that could catch on controls or moving machinery.

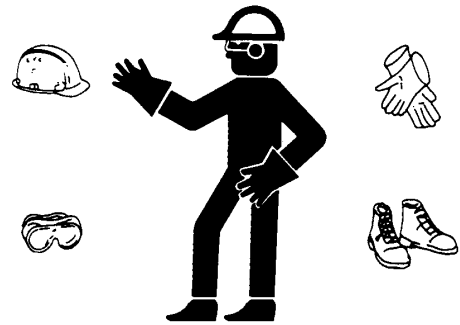

## Electrical Safety

**WARNING** Always ensure power cords are properly grounded. It is important to remember that you are working in a wet environment with electrical devices. Proper ground connections help to minimize the chances of an electric shock.

Frequently inspect electrical cords and unit for damage. Have damaged components replaced and service performed by a qualified electrician.

Do not carry electrical devices by the cord.

**NOTICE:** Always connect units to the proper power source as listed on the unit, or in the owner's manual. On units with two power cords, plug each cord into separate power circuits. Do not plug into both outlets of one duplex receptacle.

**NOTICE:** Disconnect the machine from the power source before attempting any maintenance or adjustment.

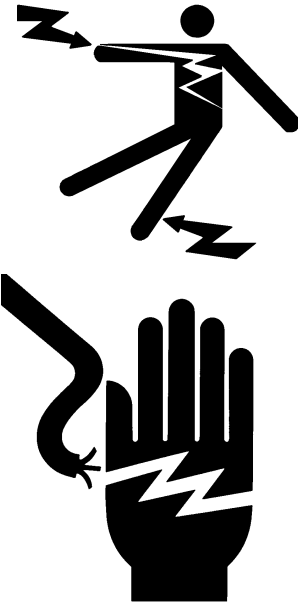

## Units With Hydraulics

Although the hydraulic pressures in this machine are low compared to some hydraulically operated equipment, it is important to remember that a sudden hydraulic oil leak can cause serious injury, or even be fatal if the pressure is high enough.

**WARNING** Escaping fluid under pressure can penetrate the skin causing serious injury. Keep hands and body away from pinholes which eject fluid under pressure. Use a piece of cardboard or paper to search for leaks. If any fluid is injected into the skin, it must be immediately removed by a doctor familiar with this type of injury.

**NOTICE:** wear safety glasses, and keep face clear of area when bleeding air from hydraulic system to avoid spraying oil into eyes.





# INSTRUCTION SHEET

Hydraulic Clamping Kit for No.412 and No.618

A1870301, A1262301

## Crush Points

Hydraulically operated jaws are operated under pressure. Anything caught in the jaws will be crushed. Keep fingers, feet, arms, legs, and head out of the jaw area. Always check pipe alignment with a pencil or similar object.

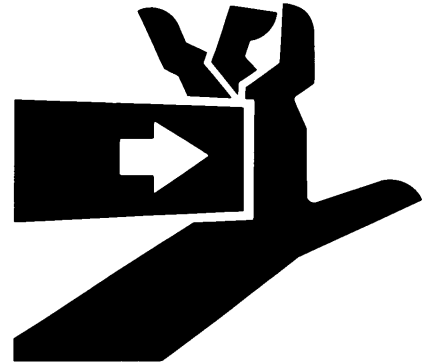

## Remove Fixed Jaw Brace

Using the 3/8" hex key wrench supplied with carriage, remove the bolt on the operator side fixed jaw brace. Remove the fixed jaw brace.



PH03781-2-23-09

## Drill Mounting Holes

### No.412/T412

Using Appendix A jaw drill pattern, drill 4 mounting holes 1-1/4" deep using the supplied "F" size drill bit and electric drill.

### No.618/T618

Using Appendix B jaw drill pattern, drill 4 mounting holes 1-1/4" deep using the supplied "F" size drill bit and electric drill.

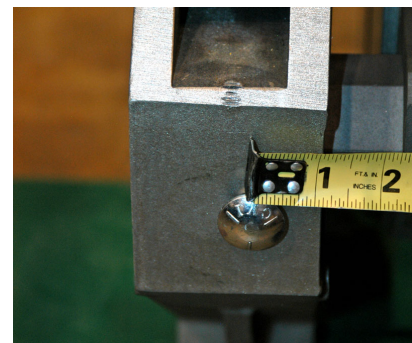

PH08823-3-18-09

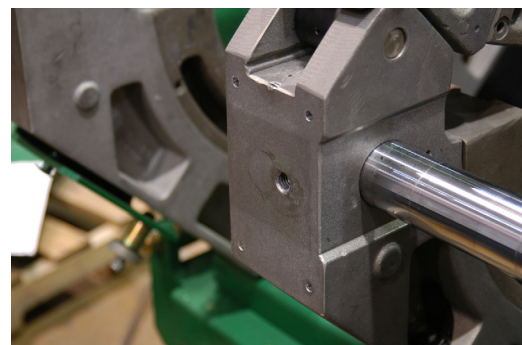

PH03786-2-23-09



# INSTRUCTION SHEET

Hydraulic Clamping Kit for No.412 and No.618

A1870301, A1262301

## Drill Mounting Holes (continued)

After drilling the holes, use the supplied 5/16-18NC tap and tapping fluid to thread the holes 3/4" deep using a tap wrench.



## Prepare Cylinders

Remove plugs with a 3/16" hex key wrench and drain fluid from the cylinders. Extend the cylinder to remove fluid from the rod end of the cylinder. Use caution when extending and retracting the cylinder so you do not shoot fluid out of the ports.



## Remove Upper Jaws

Remove the inner fixed upper jaw and inner movable upper jaw.  
Remove the detent pin from the rear of the upper jaws and remove the upper jaws.

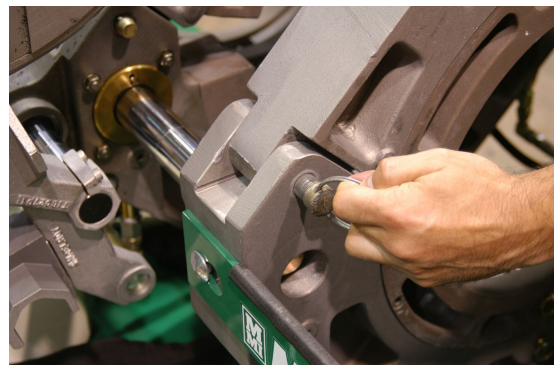



# INSTRUCTION SHEET

Hydraulic Clamping Kit for No.412 and No.618

A1870301, A1262301

## Reinstall New Upper Jaws

Attach the new clamp knob plate to the new upper inner jaws and replace the plates on the old outer jaws with the #10-24unc flat head screws and a 1/8" hex key wrench.



PH03792-2-23-09

Attach the inner fixed upper jaw to the lower jaw using the upper jaw detent pin.  
Repeat this for the inner movable upper jaw.

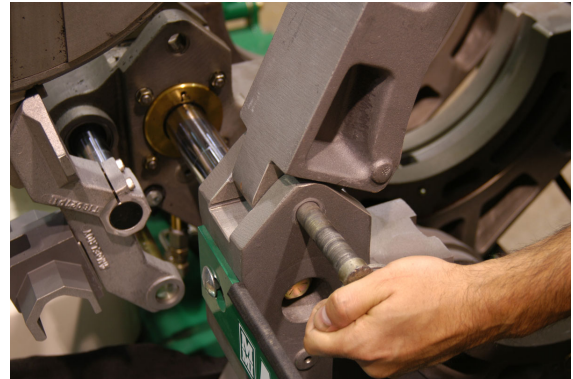

PH03793-2-23-09

## Remove Clamp Knobs

Loosen the set screw on the clamp knob using a 3/32" hex key wrench. Remove the clamp knob pin and remove the clamp knob.

**NOTE:** Clamp knob pins will be re-used.



PH03794-2-23-09



PH03795-2-23-09



# INSTRUCTION SHEET

Hydraulic Clamping Kit for No.412 and No.618

A1870301, A1262301

## Install Hydraulic Cylinders

Place the clamping cylinder on the lower jaw and insert the clamp knob pin.

**NOTE:** Be sure cylinder rod set screw is on the inboard side of the jaw.



PH03796-2-23-09

Tighten the cylinder rod set screws with a 3/32" hex key wrench.



PH03797-2-23-09

## Hydraulic Cylinder Manifold Bracket

### No.412/T412:

Attach new fixed jaw brace supplied with kit. Attach the molding and No.412 label to the brace.

### No.618/T618:

Re-attach the original fixed jaw brace.

Attach the hydraulic cylinder manifold bracket using the 4 5/16"-18unc bolts and lock washers, and a 1/2" wrench.

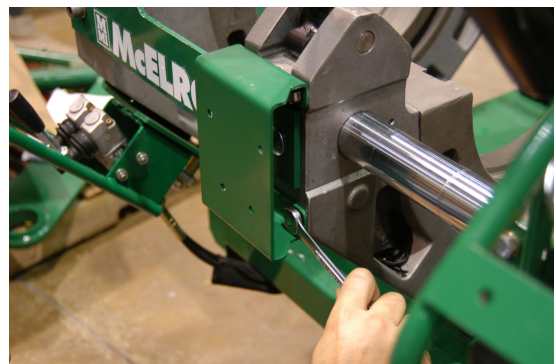

PH03798-3-9-09





# INSTRUCTION SHEET

Hydraulic Clamping Kit for No.412 and No.618

A1870301, A1262301

## Assemble Hydraulic Manifold

**NOTE:** Refer to drawing 1870501 at the end of this instruction sheet for the hydraulic plumbing schematic. For this section you will need a 9/16" wrench, 5/8" wrench and 1" wrench.  
Remove cartridge valve next to the P port.

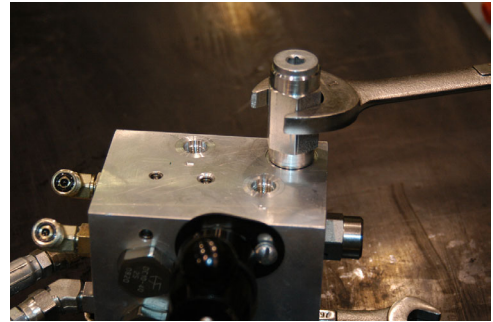

PH03822-3-9-09

Insert a 90° elbow into the P port of the manifold.

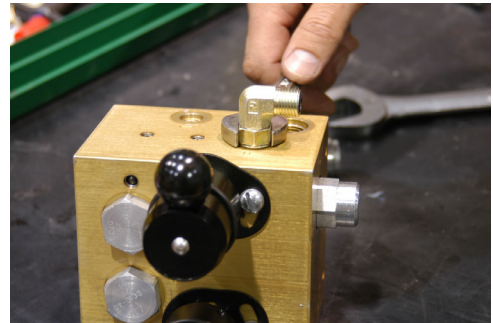

PH03799-3-9-09

Insert straight adapter into the T port of the manifold.

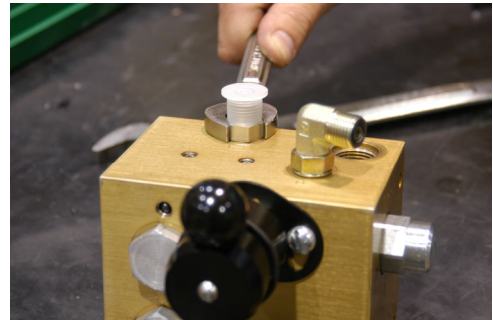

PH03800-3-9-09

Re-install the cartridge valve into the cavity next to the P port of the manifold.

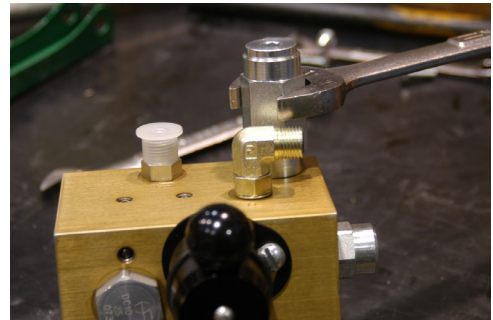

PH03801-3-9-09

Insert the (2) 45° fittings into the A1 and B1 ports of the manifold.  
Insert the (2) 90° fittings into the A2 and B2 ports of the manifold.

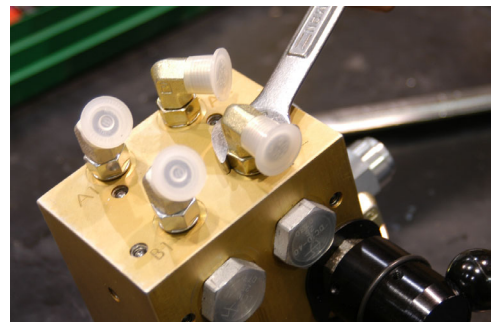

PH03802-3-9-09



## Install Manifold

Attach the manifold to the manifold bracket using the (4) 1/4"-20unc bolts and lock washers with a 7/16" wrench.



PH03803-3-9-09

## Install Cylinder Hardware

For this section you will need a 9/16" wrench, 5/8" wrench, 11/16" wrench, 3/4" wrench and 13/16" wrench.

Attach the tee fittings to the cylinder attached to the inner fixed jaw. Rotate the tee part of the fitting toward the outer fixed jaw cylinder. Attach a straight fitting to the top port of the tee fitting and a 90° elbow fitting pointing up to the bottom port.



PH03804-3-9-09

Attach the quick disconnects (QD) and fittings to the tee fitting on the inner fixed jaw cylinder.

Install male QD on top port and female QD on bottom rod port.

Teflon tape is not required on the o-ring type fittings.

Be sure to use Teflon tape on the tapered pipe threads that screw into the quick disconnects.

**NOTICE:** Use caution when wrapping the fitting with Teflon tape so that no tape goes beyond the end of the fitting. This could cause loose pieces of the tape to contaminate the hydraulic system.



PH03805-3-9-09

Attach the 90° elbow fittings on the outer fixed jaw cylinder. Rotate the elbow fittings toward the inner fixed jaw cylinder.



PH03806-3-9-09



## Install Cylinder Hardware (continued)

Attach the 90° elbow fittings on the inner movable jaw cylinder. Rotate the elbow fittings toward the outer movable jaw cylinder.

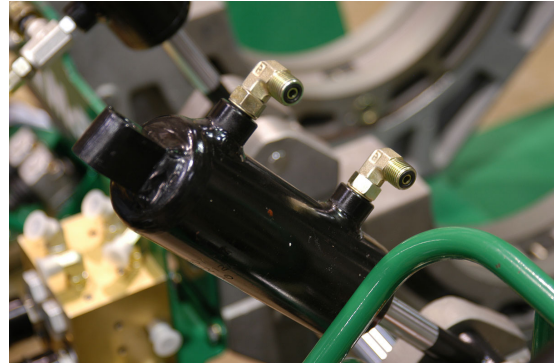

PH03807-3-9-09

Attach the tee and elbow fittings to the outer movable jaw cylinder. The elbow fittings are attached on the outboard side of the tee fitting (side opposite the inner movable jaw).

**NOTE:** Fixed jaw cylinders should have ports pointing outboard (toward the operator), and movable jaw cylinders should have ports pointing inboard (away from operator). Cylinders can be rotated to achieve proper port orientation.

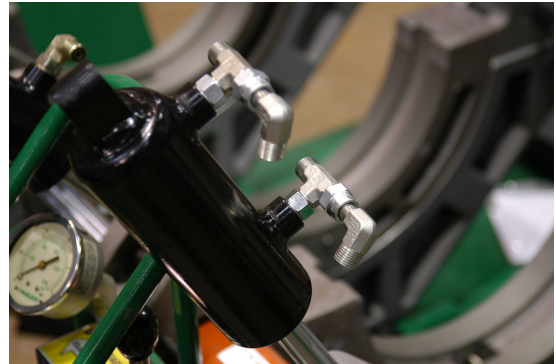

PH03808-3-9-09

## Attach Hoses to Cylinders

Attach 1 male and female QD's to the fixed jaw cylinder hoses. Be sure to use Teflon tape on the tapered pipe threads.

Attach the hoses between the fixed jaw and movable jaw paired cylinders using a loop in between the cylinders.

Be sure not to cross the hoses. Top ports are connected with 1 hose and bottom ports are connected with 1 hose.

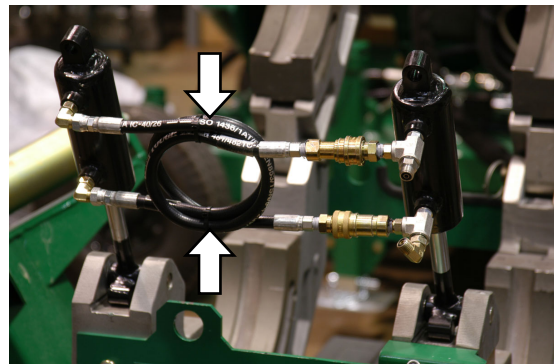

PH03809-3-9-09

Use hoses ties at the top and bottom of the loop.

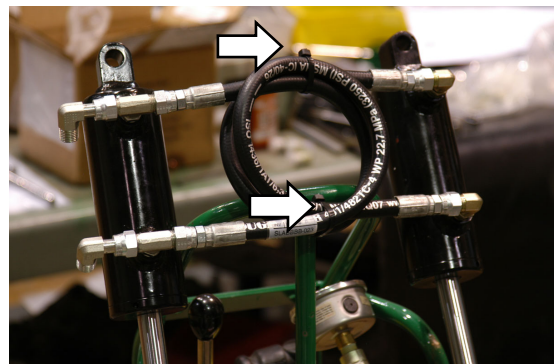

PH03810-3-9-09



# INSTRUCTION SHEET

Hydraulic Clamping Kit for No.412 and No.618

A1870301, A1262301

## Connect Cylinders to Manifold

Connect the hoses from the inner fixed jaw cylinder to the manifold. The top cylinder port connects to manifold port B1. The bottom cylinder port connects to manifold port A1.

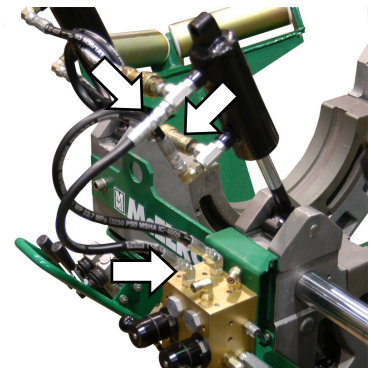

Connect the hoses from the outer movable jaw cylinder to the manifold. The top cylinder port connects to manifold port A2. The bottom cylinder port connects to manifold port B2.

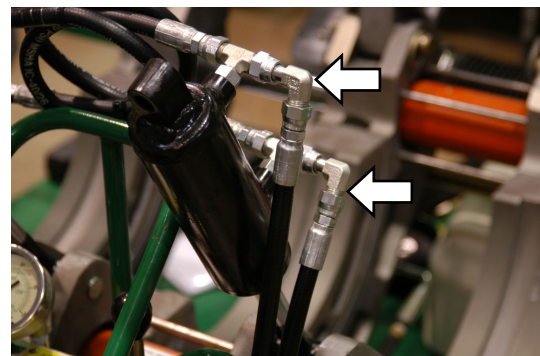
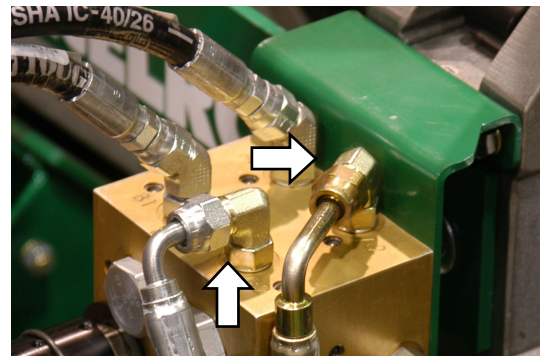



## Connect Clamping Manifold to Fusion Manifold

Loosen the DataLogger elbow fitting and rotate the fitting as pictured and tighten fitting.

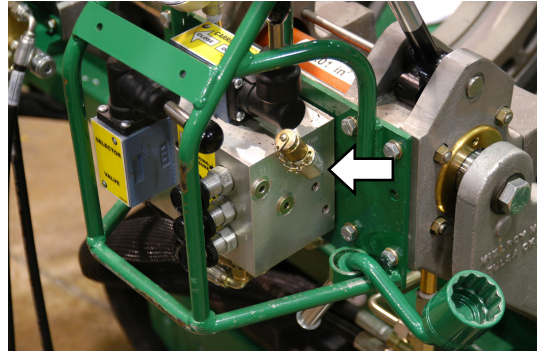

PH03813-3-9-09

Using 1/4" hex key wrench, remove plugs in ports P1 and T1 on right side of carriage manifold. Attach the (2) elbow fittings on the P1 and T1 ports of the carriage manifold.

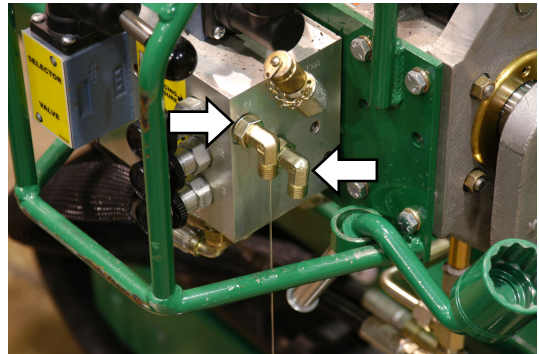

## Connect Clamping Manifold to Fusion Manifold

Connect hoses from the clamping manifold to the carriage manifold. Clamping manifold port P connects to carriage manifold port P1. Clamping manifold port T connects to carriage manifold port T1.

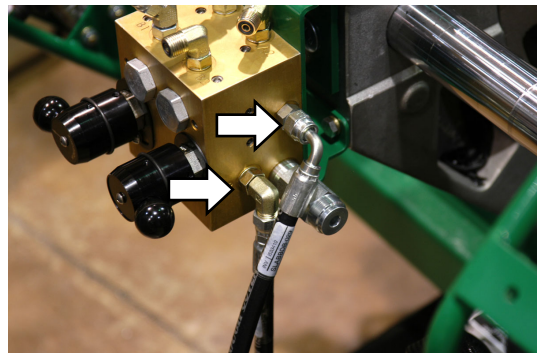

PH03812-3-9-09

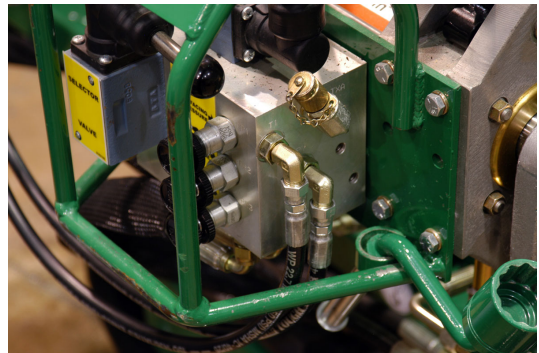

PH03815-3-9-09



# INSTRUCTION SHEET

Hydraulic Clamping Kit for No.412 and No.618

A1870301, A1262301

## Attach Clamp Cylinder Brace

Attach the brace in between the cylinders of the fixed jaws.  
Insert the retaining pins and cotter pins into the brace and cylinder.  
Repeat steps on the movable jaw cylinders.

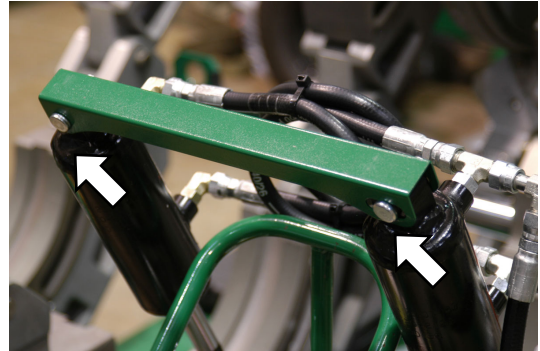

## Attach Cable Ties

Attach the remaining cable ties to the hoses as pictured.

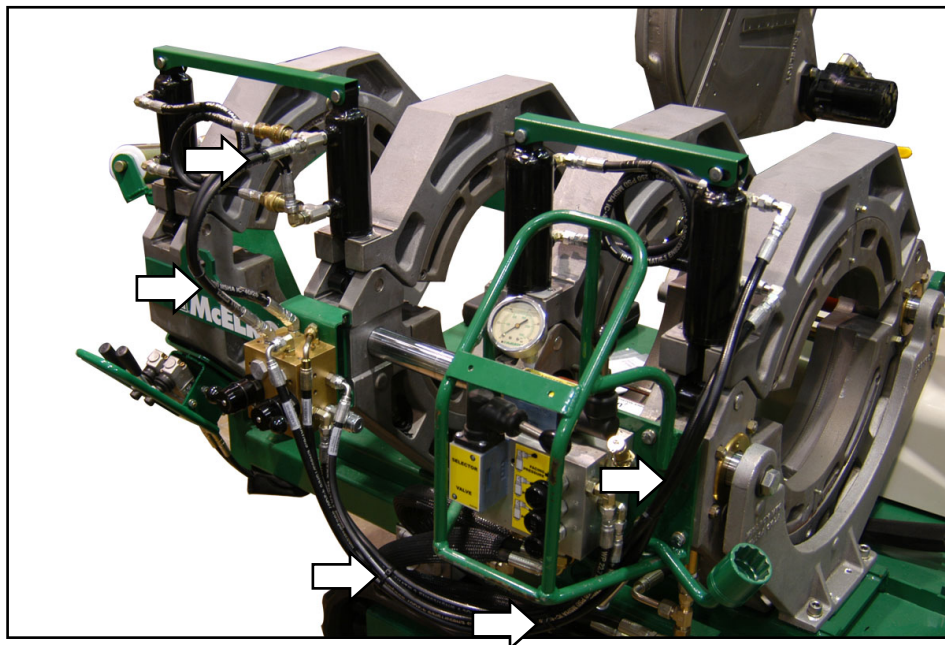

## Adjust Jaw Stops

Install bolts into the (2) new inner upper jaws until completely bottomed out. These bolts are used to adjust HI/LO during the fusion process.

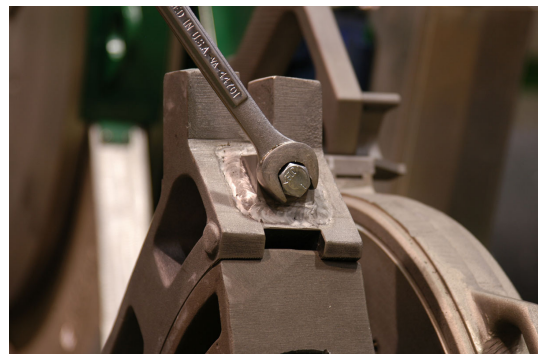



# INSTRUCTION SHEET

Hydraulic Clamping Kit for No.412 and No.618

A1870301, A1262301



PH03820-3-9-09

## Operation

### To unclamp the jaws:

With your free hand, hold the cylinder brace of the jaws.

Rotate the valve up to unclamp.

Pull the brace towards operator until the cylinders come to rest.

### To clamp the jaws:

Push the cylinder brace toward the jaws until vertical.

Rotate the valve down to clamp.



Prior to starting the machine, always ensure that the hydraulic clamping directional valves are both in the center (Neutral) position to eliminate undesired clamp cylinder movement during startup.

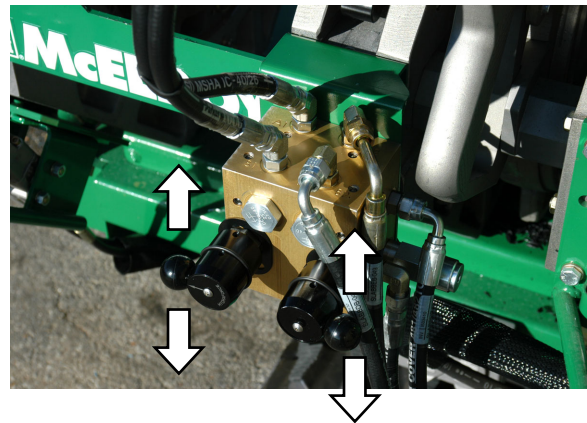

PH03821-3-9-09



The leader by design.

P.O. Box 580550 Tulsa, Oklahoma 74158-0550, USA  
[www.mcelroy.com](http://www.mcelroy.com)

## DRAWING REVISION HISTORY LISTING

**PART NO:** 187030101

**DESCRIPTION:** HYDRAULIC CLAMPING KIT FOR NO. 412 AND NO. 618 INSTRUCTION SHEET

<u>APPR.</u>	<u>REV</u>	<u>DATE</u>	<u>BY</u>	<u>DESCRIPTION OF REVISION</u>
JRP	A	1/6/10	SRB	ADDED A CAUTION TO THE LAST PAGE OF INSTRUCTION SHEET.



**APPENDIX A**  
No. 412 JAW DRILL PATTERN  
OPERATOR SIDE INNER FIXED JAW

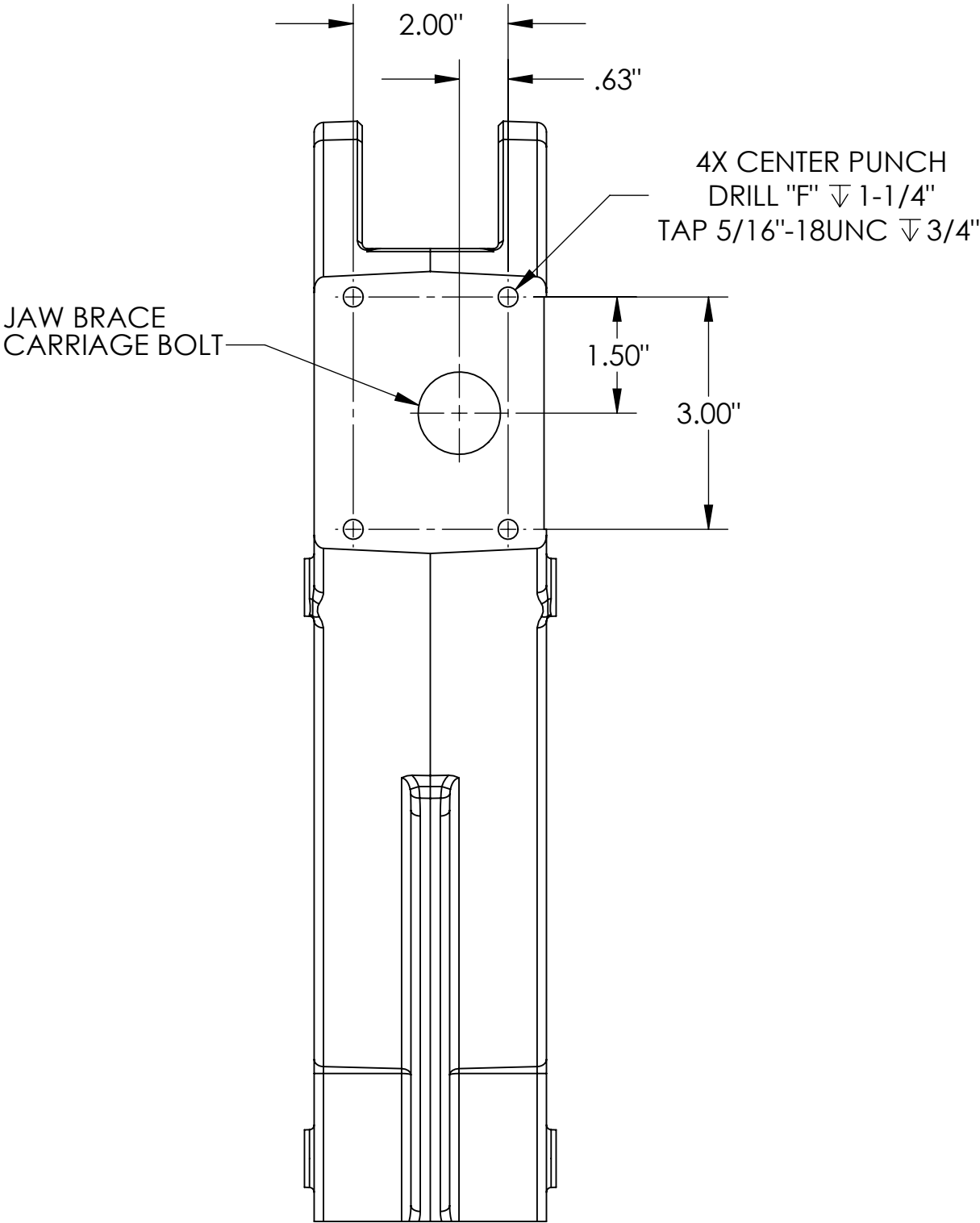

**APPENDIX B**  
No. 618 JAW DRILL PATTERN  
OPERATOR SIDE INNER FIXED JAW

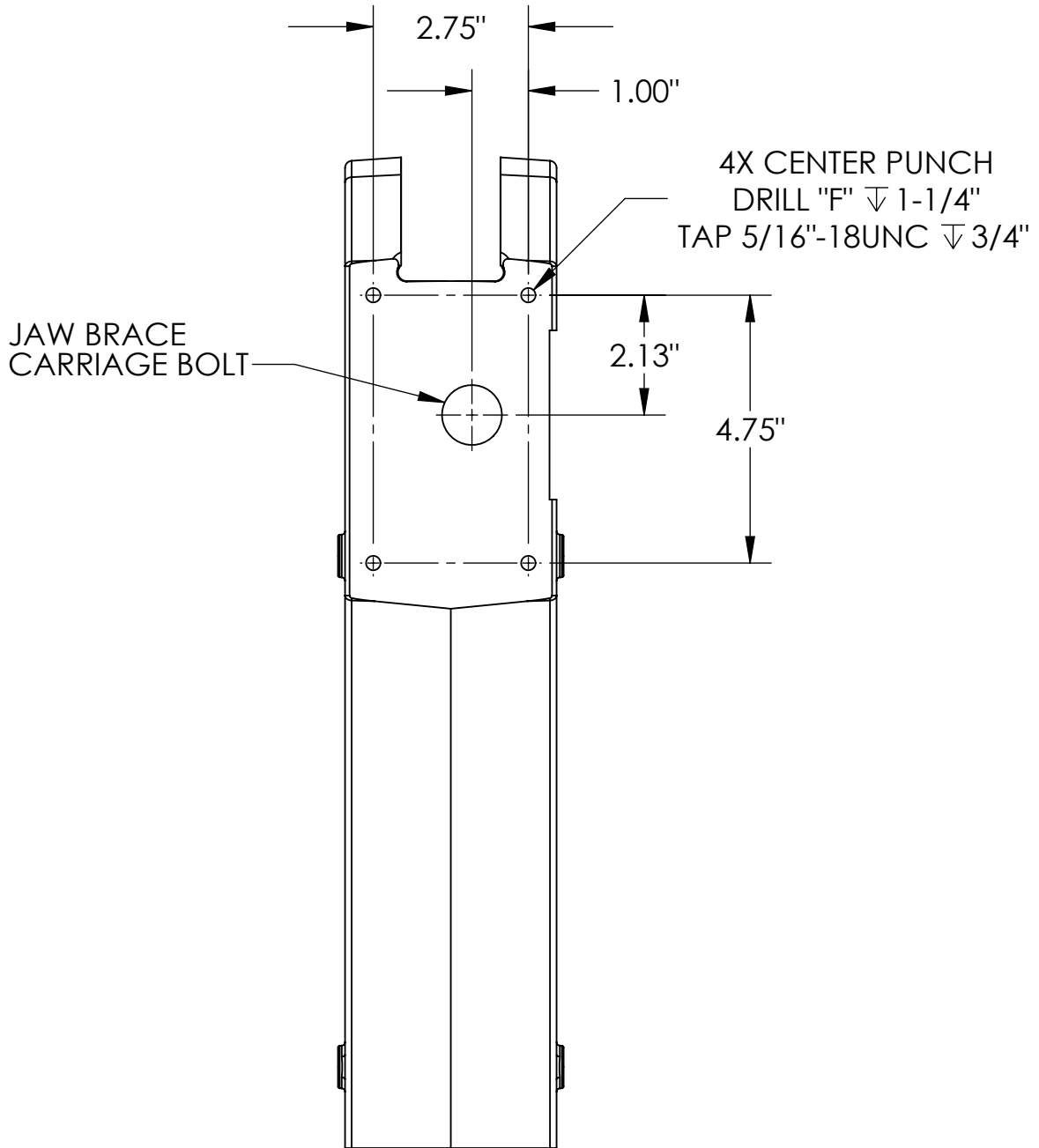



NOTE: THIS DRAWING AND THE INFORMATION CONTAINED THEREIN IS THE CONFIDENTIAL AND PROPRIETARY PROPERTY OF McElroy Manufacturing, Inc. THE DRAWING IS NOT TO BE REPRODUCED IN ANY MANNER, SUBMITTED TO OUTSIDE PARTIES FOR EXAMINATION, OR USED DIRECTLY OR INDIRECTLY FOR THE PURPOSES OTHER THAN THOSE FOR WHICH IT WAS FURNISHED WITHOUT WRITTEN PERMISSION OF McElroy Manufacturing, Inc.

- NOTES:**
1. REMOVE 6MSAE PLUG IN PORT P1 OF CARRIAGE MANIFOLD AND INSTALL ITEM 10.
  2. REMOVE 6MSAE PLUG IN PORT T1 OF CARRIAGE MANIFOLD AND INSTALL ITEM 10.

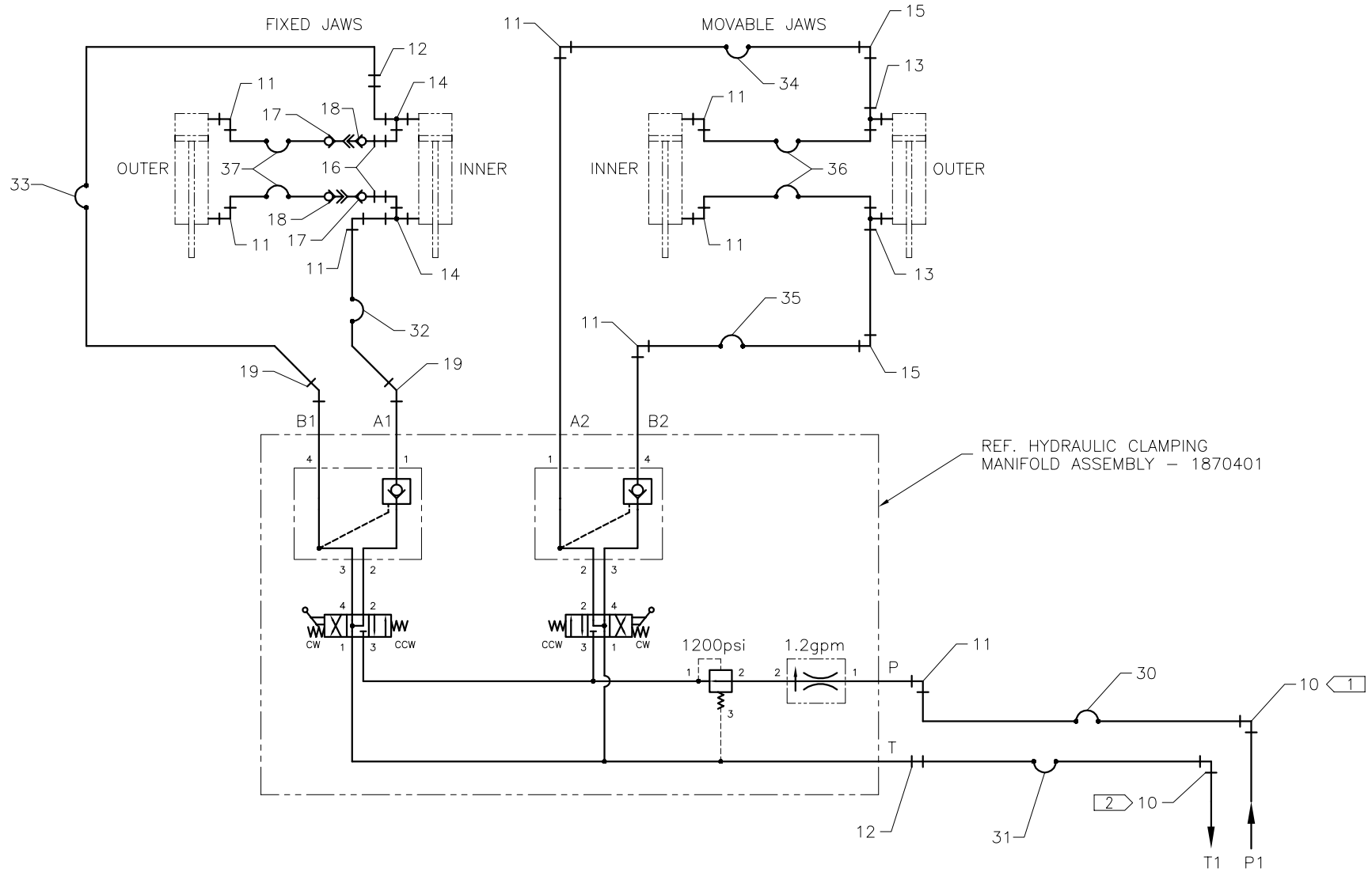

TO CARRIAGE MANIFOLD ASSEMBLY  
 (REF. TracStar 618 CARRIAGE  
 HYDRAULIC/PLUMBING SCHEMATIC-T1801001 OR  
 TracStar 412 CARRIAGE PLUMBING SCHEMATIC -  
 T1201002)

**#412/TracStar® 412/#618/TracStar® 618 HYDRAULIC  
CLAMPING PLUMBING SCHEMATIC**

Parts List

ITEM	PART NO.	QTY.	DESCRIPTION
	<b>1870501</b>		<b>ASSEMBLY</b>
	<b>A1870501</b>		<b>HYDRAULIC CLAMPING FITTING KIT</b>
10	MFQ00041	2	4MSL/6MSAE ELBOW
11	MFQ00040	8	4MSL/4MSAE ELBOW
12	MFQ00039	2	4MSL/4MSAE ADAPTER
13	MFQ00098	2	4MSL/4MSAE/4MSL BRANCH TEE
14	MFC00153	2	4MSAE/4FSAE/4FSAE RUN TEE
15	MFQ00026	2	4MSL/4FSL SWIVEL ELBOW
16	MFC00032	2	4MSAE/4MPT ADAPTER
17	MFH00001	2	1/4FNPT QUICK DISC COUPLER
18	MFH00002	2	1/4FNPT QUICK DISC NIPPLE
19	MFQ00067	2	4MSL/4MSAE 45DEG ELBOW
	<b>A1870502</b>		<b>HYDRAULIC CLAMPING HOSE KIT</b>
30	SLABBBB026	1	HOSE ASSEMBLY, OAL 26"
31	SLABBDB029	1	HOSE ASSEMBLY, OAL 29"
32	SLABBBB020	1	HOSE ASSEMBLY, OAL 20"
33	SLABBBB016	1	HOSE ASSEMBLY, OAL 16"
34	SLABBEB049	1	HOSE ASSEMBLY, OAL 49"
35	SLABBDB046	1	HOSE ASSEMBLY, OAL 46"
36	SLABBBB023	2	HOSE ASSEMBLY, OAL 23"
37	SLAFBBB025	2	HOSE ASSEMBLY, OAL 25"

## DRAWING REVISION HISTORY LISTING

**PART NO:** 1870501

**DESCRIPTION:** #412/ TracStar® 412/ #618/ TracStar® 618 HYD. CLAMPING PLUMBING SCHEMATIC

<u>APPR.</u>	<u>REV</u>	<u>DATE</u>	<u>BY</u>	<u>DESCRIPTION OF REVISION</u>
BLM	A	8/27/09	PJD	CORRECTED MANIFOLD ASSEMBLY SCHEMATIC TO REMOVE P.O. CHECK VALVE IN LINE B1 AND LINE A2 PER MANIFOLD ASSEMBLY 1870401 REV. A. CORRECTED CARRIAGE MANIFOLD ASSEMBLY REFERENCE DESCRIPTIONS TO INCLUDE T412.