

# Earthworm Hydrodrill

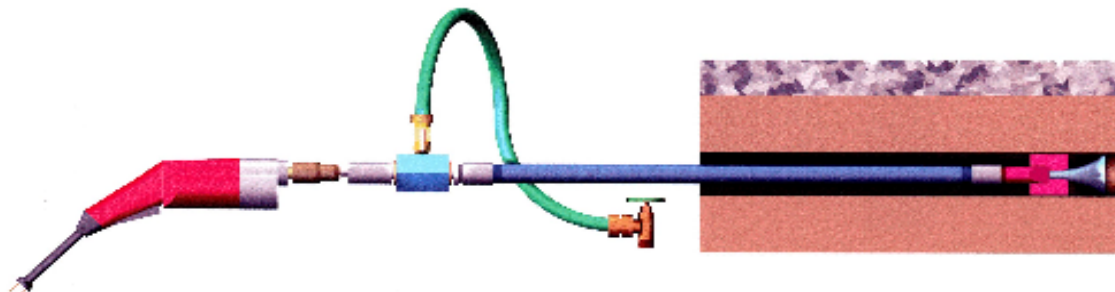

**Wheeler-Rex Earthworm Hydrodrill** is a rugged tool that is easy to use. It allows the operator to install underground from 1/2" to 6" pipes using a standard 1-1/2" 450rpm drill and a 3/4" water hose hookup.

**The 7800 Earthworm Hydrodrill** comes with a combination drive / water valve unit and a 2" auger. Other augers are available. The operator provides the drill, grounding wire and whatever lengths of 3/4" iron pipe necessary to perform the tunneling operation. The pipe may be withdrawn or left in place as needed.

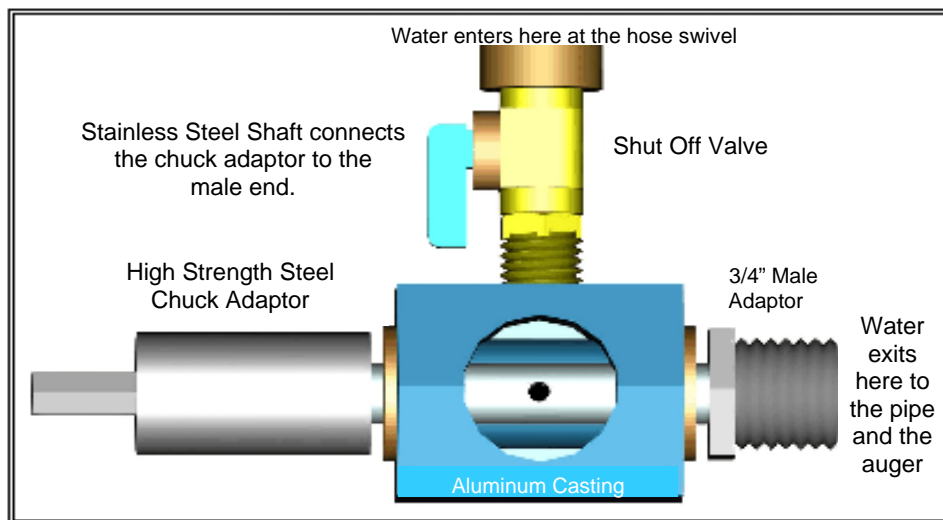

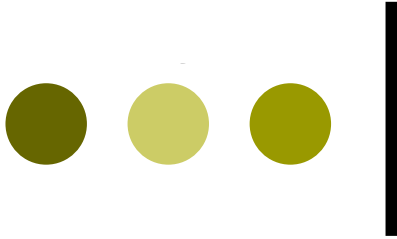

## Earthworm Hydrodrill

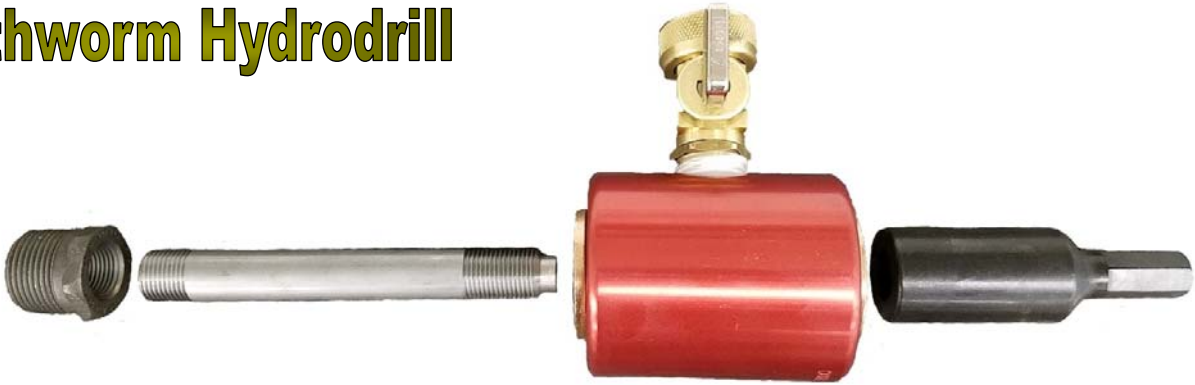

## Augers



**Grounding Instructions:** Install ground wire before using drill. Clip one end of wire on the Water Valve Stem. Clip the other end to the top of the ground rod or steel pipe (user supplies). Drive rod at least 12" into the ground several feet from the operator. *(Please note: The grounding wire is not included with the 7800 Earthworm Hydrodrill. As a separate item, you can purchase as a Wheeler-Rex Part Number 7811)*



Wheeler-Rex • Ashtabula, Ohio • Tel: 440-998-2788 or 800-321-7950 • Fax: 440-992-2925  
wheeler@wheelerrex.com • www.wheelerrex.com

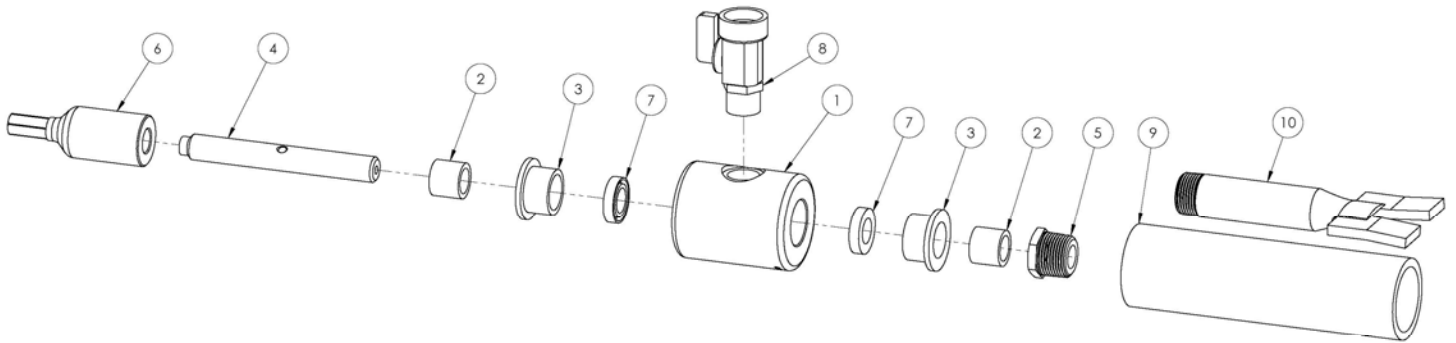
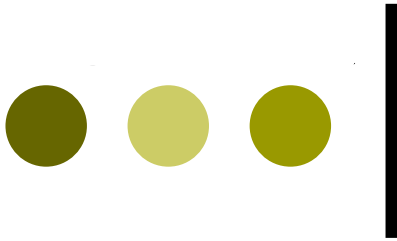

Item	Part No	Description	Qty
1	701608	Body	1
2	277342	Bearing, 7800	2
3	277341	Flange Bearing, 7800	2
4	7803	Shaft	1
5	277279	3/4" x 3/8" NPT XH Hex Reducer Bushing	1
6	7807	Hex Drive Adapter	1
7	277340	Seal, 7800	2
8	7805	Water Valve, 7800	1
9	701609	PVC Sleeve	1
10	7802	2" Auger	1
11	7811	Ground Wire 4' long ***Not Shown***	1





# Operating Instructions

When boring a hole, carefully align pipe with the opposite side. If you stay on target for the first ten (10) feet, the tool will run straight for the remainder of the bore.

Please **OIL FREQUENTLY** with a good lubricating oil on both the inside and outside, on the shaft.

Different soils will require different amounts of both water and pressure on the tool. For example, in gummy / stiff dirt or clay, a 3" bit will drill faster than a 2" bit.

When boring through rocky soil, bore with caution. If you hit a rock, the bit will veer off track. If this happens, the drill should be shut off and the water left running. With several forward and backward motions, you can usually push the rock aside so that the bit will pass without losing its alignment. If this does not work, turn the drill on and move very slowly until the bit has made a groove in the rock. Then it will not slip out of alignment and you may exert more pressure. (We **do not** guarantee our bit as rock bits, but users are generally getting good results).

**HELPFUL HINTS** to ensure proper boring:

- ⇒ **NEVER** put side pressure on the drill. The pressure must be exerted in a straight forward motion. Side pressure or putting "English" on the drill will wear out the bearings prematurely.
- ⇒ You **MUST** at all times run the tool with **WATER** and use a **STRAIGHT** piece of pipe.
- ⇒ It is a good idea to use a drill with a chuck no larger than 3/4". We recommend a 1/2" drill for the Earthworm Hydrodrill. Threads on couplings should be checked frequently. If they are worn, they should be replaced.
- ⇒ To get **best results**, use a 450rpm drill. **DO NOT** use a drill over 700rpm.
- ⇒ **DO NOT** use an **AIR IMPACT TOOL** or an **ELECTRIC IMPACT TOOL**.
- ⇒ **Take your time**. It is much better to bore **SLOWLY** and **CAREFULLY** than hurriedly.

In boring with a **4" or larger bit**, make a 2" bore as above. Then remove the 2" bit and replace it with a 4" or larger **REVERSE** bit. Then simply back out of the hole you just dug. **DO NOT REVERSE THE DIRECTION OF THE DRILL!!** The reverse bits are designed to work with the drill motor running in the forward direction. Running the drill motor in reverse will **UNSCREW** the pipe threads and leave your expensive bit somewhere in the middle of the hole.

Be sure to maintain a constant drill speed when the reverse bore is being made. This assures you of a clean bore, and saves undue strain on your drill. The pipe should then be **immediately** installed into the bore.

**CAUTION:** This unit should **NOT** be used without proper grounding. Attach the ground wire (not included; Wheeler-Rex Part Number 7811) to the water inlet valve and to any solid ground; preferably a steel rod driven into the ground. More wire may be needed than the length provided by the 7811. See grounding instructions on previous page.

