

Guillotine Pipe Cutters

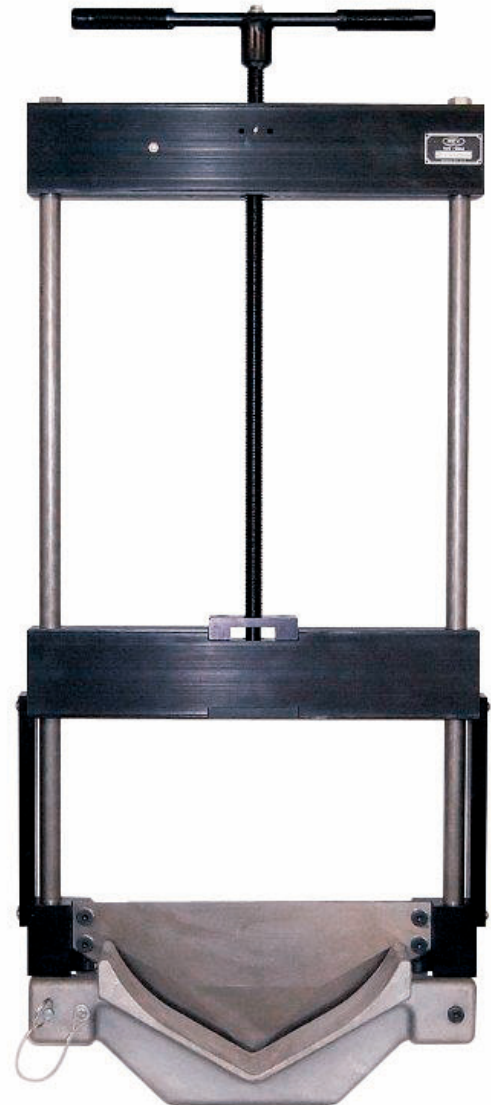

Model 1894

For cutting 12" (315mm) diameter HDPE pipe up to SDR17. Max pipe OD capacity 13.2" (335mm)



Model 1897

For cutting 12" (315mm) diameter HDPE pipe up to SDR17. Max pipe OD capacity 13.2" (335mm)

Guillotine Pipe Cutters

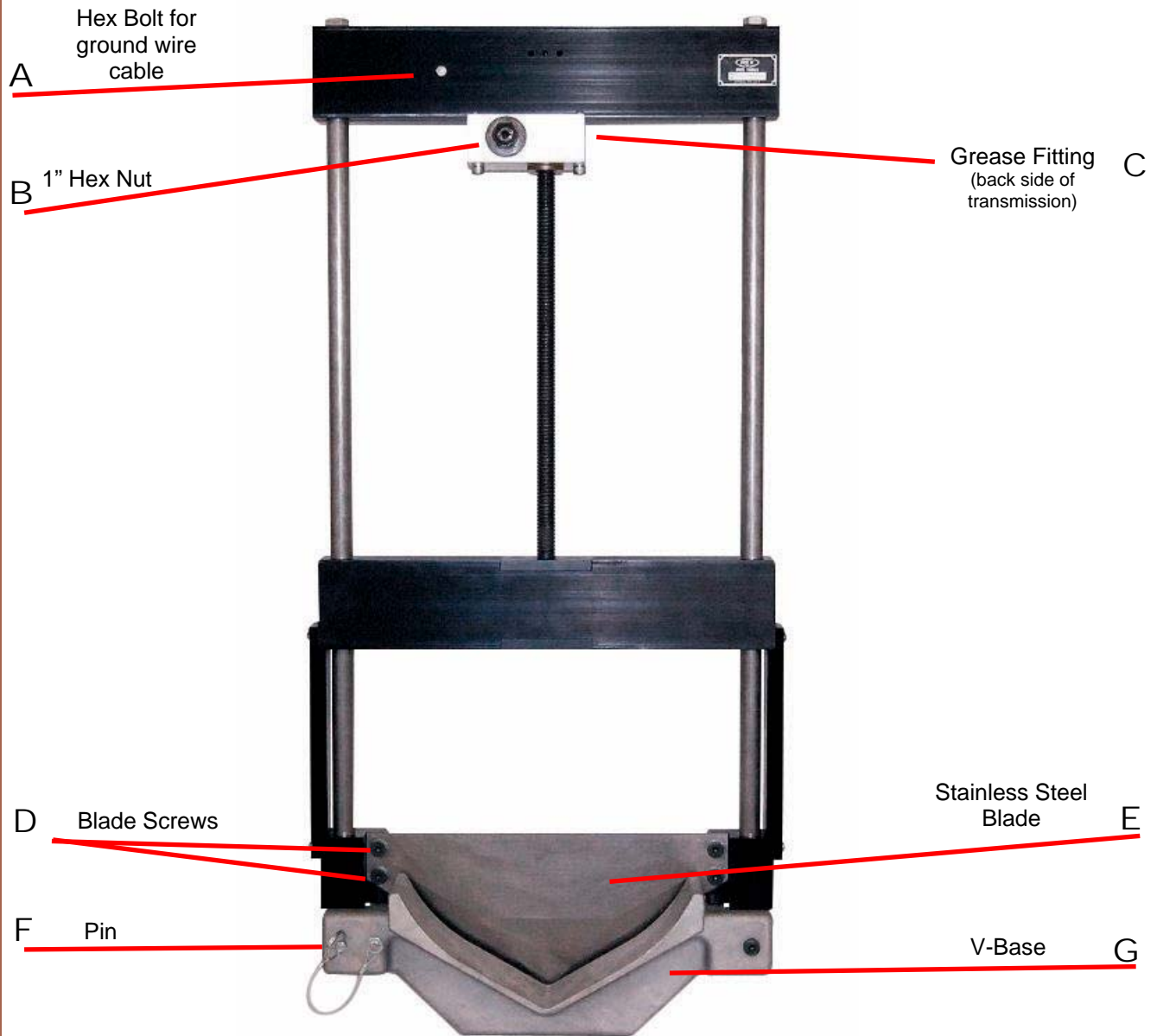

Model 1894

Guillotine Pipe Cutters

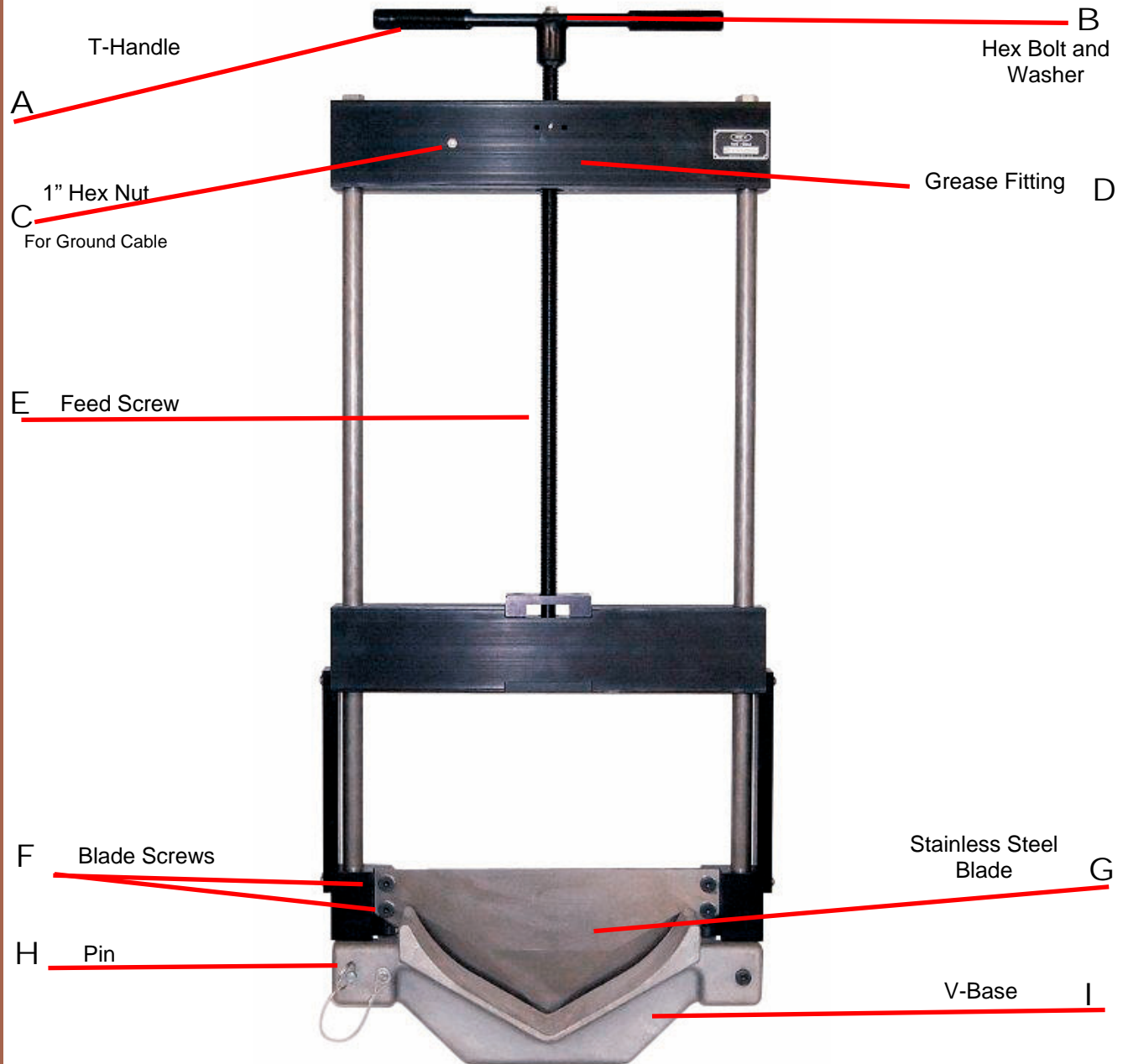

Model 1897

Guillotine Pipe Cutters



While wearing gloves, remove rubber guard before cutting pipe.



- ◇ **1897** - Turn handle and open blade all the way
- ◇ **1894** - Attach power drive to hex and open the blade all the way

Pull pin to allow bottom of V-Base to swing open. Place cutter over pipe. Swing V-Base back and replace pin.

Guillotine Pipe Cutters

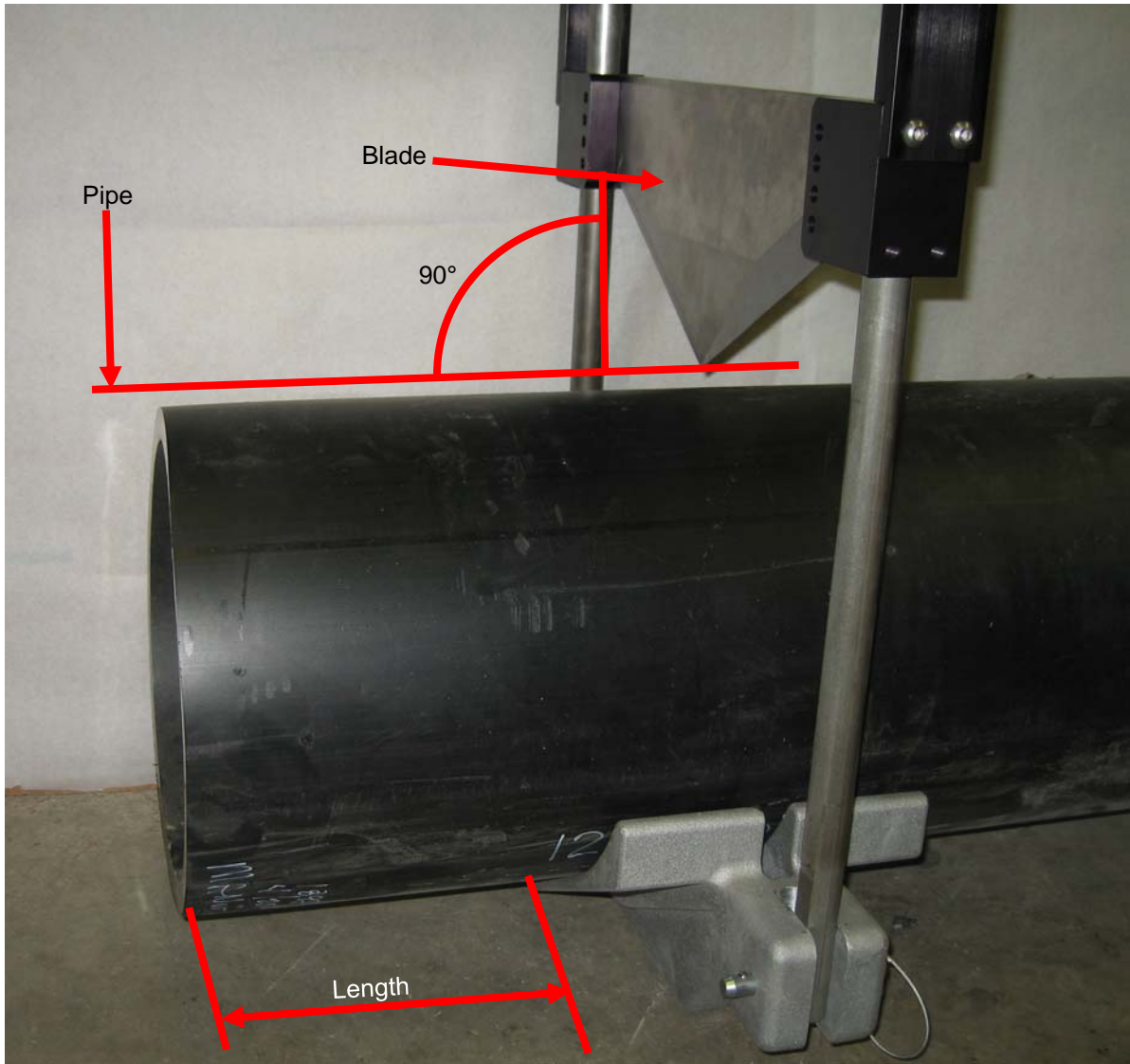

Make sure pipe is properly placed in the V-Base. Blade must be perpendicular to the pipe before a cut can begin.

Length = Pipe Diameter: Minimum suggested cut length is the pipe diameter

Example: 12" OD pipe, the minimum cut length should be 12" long

Guillotine Pipe Cutters

Maintenance

◇ 1894

Grease transmission with 2 to 3 pumps prior to use. The grease fitting is located on the back side of the transmission housing.

◇ 1897

Make sure feed screw is kept greased and free of dirt. Grease will collect in the picket under the threaded bushing. As you close the blade, grease will be applied to the feed screw. Approximately 1/2 way down, add 2 to 3 more pumps of grease. Then continue to close the blade. Open blade all the way and you are now ready to cut the pipe.

◇ All Models

Sharpening the blade or replacing the blade:

1. Blade is extremely sharp and always use gloves
2. Open the cutter so the entire blade is visible and above the V-Base
3. Remove four (4) blade screws. Then use the Wheeler Rex Model 7325 Blade Sharpener to sharpen the blade. Always wear gloves. Do not use a hand held grinder or a bench grinder to sharpen blades.

Guillotine Pipe Cutters

WARNING

GENERAL TOOL OPERATION WARNINGS

FOR ALL TOOLS-

1. **Keep Guards in Place** and in working order.
2. **Remove Adjusting Keys and Wrenches** from tool before turning it on.
3. **Keep Work Area Clean.** Cluttered areas and benches invite accidents.
4. **Avoid Dangerous Environment.** Don't use power tools in damp or wet locations. Keep work area well lit. Don't expose power tools to rain.
5. **If you must use an electric tool in a damp or wet location;** make sure it is plugged into a circuit which is protected by a ground fault interrupt.
6. **Keep Children Away. ALL VISITORS SHOULD BE KEPT A SAFE DISTANCE FROM WORK AREA.**
7. **Store Idle Tools** in dry, high, or locked-up place out of reach of children.
8. **Don't Force Tool.** It will do a better and safer job at the rate for which it is designed.
9. **Use Right Tool.** Don't force a small tool or attachment to do the job of a heavy-duty tool.
10. **Wear Proper Apparel.** No loose clothing or jewelry to get caught in moving parts. Rubber gloves and footwear are recommended when working outdoors.
11. **Use Safety Glasses.**
12. **Don't Abuse Cord.** Never carry tool by cord or yank it to disconnect from receptacle. Keep cord from heat, oil, and sharp edges.
13. **Secure Work.** Use clamps or vise to hold work when practical. It's safer than using your hand and it frees both hands to operate tool.
14. **Don't Overreach.** Keep proper footing and balance at all times.
15. **Maintain Tools Properly.** Keep tools sharp and clean for best and safest performance. Follow instructions for lubricating and changing accessories. Equipment operators must have proper maintenance & instruction sheets. Be sure the tool operator reads and understands this information. If you don't have current maintenance and instruction sheets, contact the factory & we will supply them at no charge.
16. **Disconnect Tools** when not in use; before servicing; when changing accessories such as dies, cutters, etc.
17. **Avoid Accidental Starting.** Don't carry plugged-in tool with finger on switch. Be sure switch is off when plugging in.
18. **Outdoor Use Extension Cords.** When tool is used outdoors, use only extension cords suitable for use outdoors and so marked.
19. **Wear Ear Protection** if exposed to long periods of very noisy shop operations.
20. **Do not operate** tools while under the influence of alcohol, drugs or medication.



WHEELER-REX LIMITED LIFETIME WARRANTY

WHEELER-REX covers its products with a Limited Lifetime Warranty, with exception of pipe threading machines which have a Limited Three Year Warranty (including electric motors). Warranties from manufacturers of components used in our products may pre-empt the Wheeler-Rex warranty. Wheeler-Rex warrants against defects in material or workmanship. To take advantage of this warranty, the complete product must be delivered prepaid to Wheeler-Rex or any WHEELER-REX AUTHORIZED SERVICE CENTER. No tools are to be returned to the factory without receiving prior authorization. Obviously, failures due to misuse, abuse, or normal wear and tear are not covered by this warranty. NO OTHER WARRANTY, WRITTEN, OR ORAL, APPLIES. THERE ARE NO WARRANTIES WHICH EXTEND BEYOND THE DESCRIPTION ON THE FACE HEREOF. No employee, agent, dealer, or other person is authorized to give any warranty on behalf of Wheeler-Rex. Warranted products will be repaired or replaced at our option, at no charge and returned to you via prepaid transportation. Such replacement or repair is the exclusive remedy available from Wheeler-Rex. Wheeler-Rex is not liable for damage of any sort, including incidental and consequential damages. Some U.S.A. states do not allow the exclusion or limitation of incidental or consequential damages, so the above limitation or exclusion may not apply. This warranty gives you specific legal rights, and you may also have other rights which vary from state to state.

Form # 1031

Guillotine Pipe Cutters

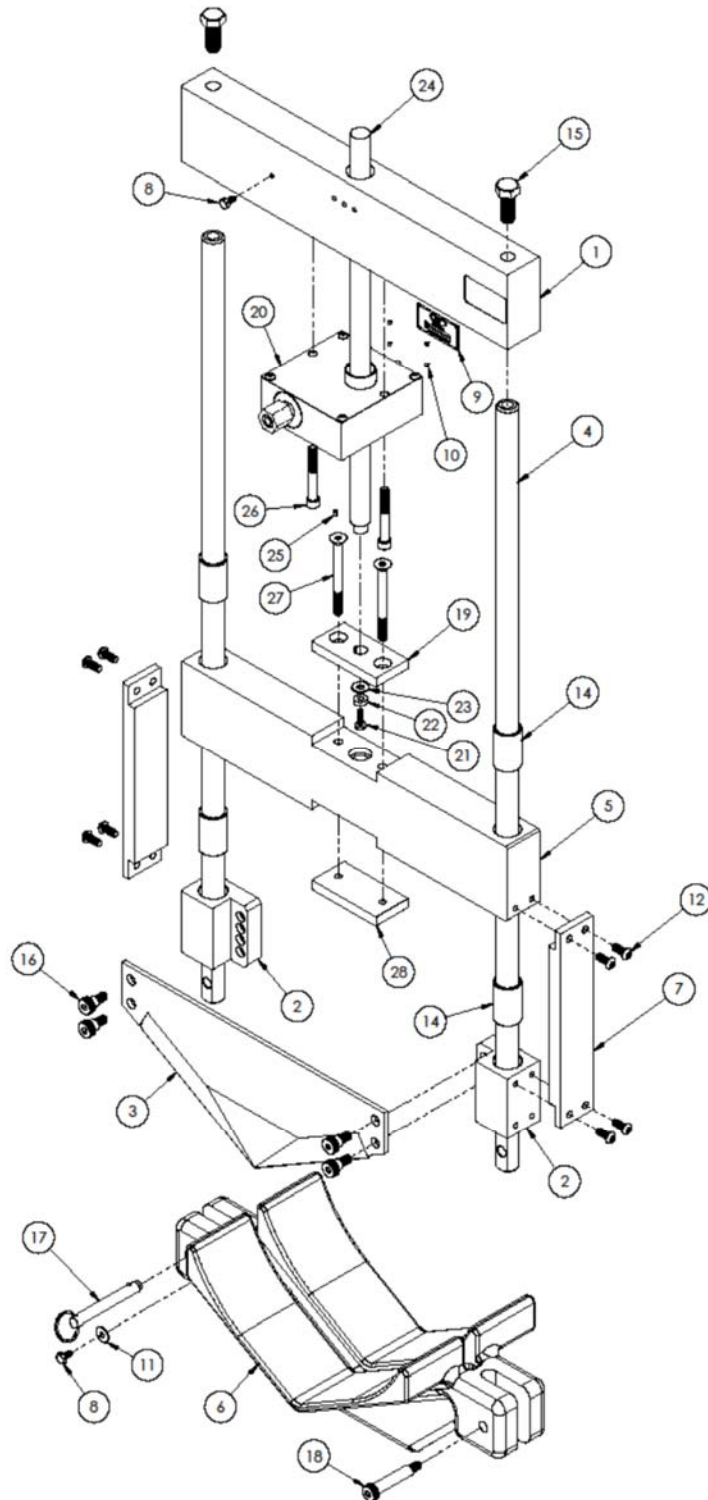

Model 1894

Guillotine Pipe Cutters

Item	Part No	Description	Qty
1	701283	HEAD BAR	1
2	701453	BLADE BLOCK	2
3	701454	POINTED BLADE	1
4	701285	GUIDE ROD	2
5	701284	BEARING BAR	1
6	701439	V-BASE (MACHINED)	1
7	701459	SIDE SUPPORT	2
8	276536	1/4"-20 x 1/2 SS HHCS	2
9	700595	NAME PLATE	1
10	276203	METAL TAK	4
11	276540	1/4" FLAT WASHER	1
12	276527	5/16-18 x 3/4" SS BHCS	8
13	701456	FEED SCREW ASSEMBLY	1
14	276637	SLEEVE BEARING	4
15	276644	5/8-11 X 1 1/2" HEX HEAD CAP SCREW	2
16	277232	1/2" x 3/8" L SOCKET HEAD SHOULDER SCREW	4
17	277233	1/2" DIA x 3.1" L COTTERLESS PIN	1
18	277235	1/2" DIA X 2 1/4" L SHSS	1
19	701286	KEYED PLATE	1
20	700560	TRANSMISSION ASSEMBLY	1
21	276649	1/4-20 x 3/4" HEX HEAD CAP SCREW	1
22	276537	WASHER SS	1
23	275685	5/16" FLAT WASHER	1
24	700555	DRIVE SCREW	1
25	276647	KEYWAY 1/8" SQUARE x 1/4" LONG	1
26	276648	3/8-16 x 2 3/4" LONG SS SHCS	2
27	277236	3/8-16 X 4" LONG FHCS	2
28	701281	PRESSURE PLATE	1
29	276073	6" LANYARD ***NOT SHOWN***	1

Model 1894

Guillotine Pipe Cutters

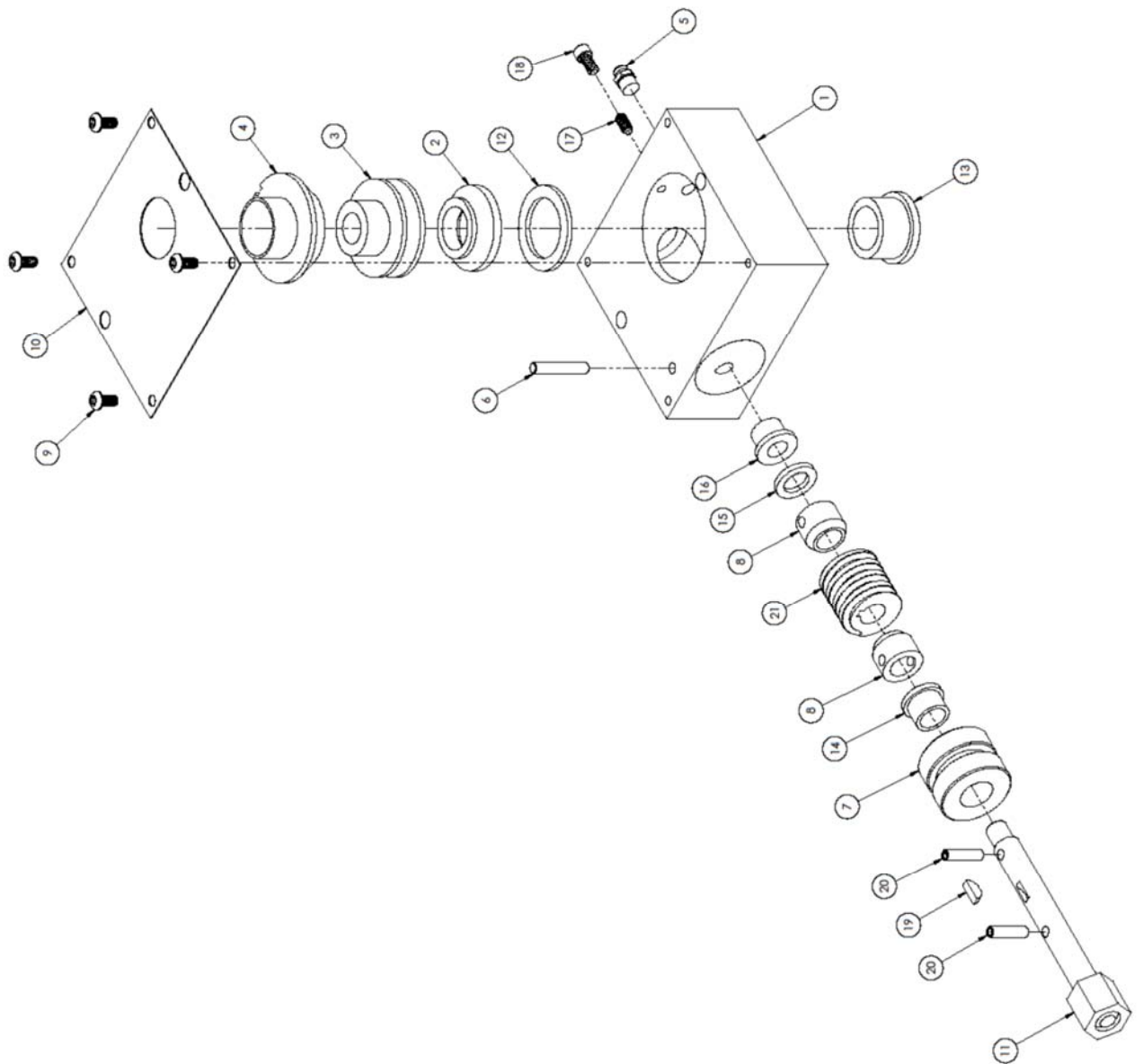

700560 Transmission Assembly

Guillotine Pipe Cutters

Item	Part No	Description	Qty
1	700582	TRANSMISSION HOUSING	1
2	700656	COLLAR	1
3	700658	WORM GEAR	1
4	700557	SPACER	1
5	275488	GREASE FITTING	1
6	275737	1/4" x 1 1/2" DOWEL PIN	1
7	700547	PLUG	1
8	700548	COLLAR	2
9	276651	1/4-20 x 1/2" STAINLESS STEEL BHCS	4
10	700545	COVER PLATE	1
11	700670	SHAFT ASSEMBLY	1
12	276640	BEARING (TT1900)	1
13	276643	BEARING (EF162212)	1
14	276641	BEARING (FF842-1)	1
15	276639	BEARING (TT1002)	1
16	276642	BEARING (EF081208)	1
17	276118	1/4-20 x 1/2" FULL DOG SET SCREW	1
18	276566	1/4-20 x 1/2" SHCS	1
19	276654	WOODRUFF KEY #605 3/16 x 5/8	1
20	276652	1/4 DIA x 1" ROLL PIN	2
21	276653	WORM GEAR (H1066 RH)	1

700560 Transmission Assembly

Guillotine Pipe Cutters

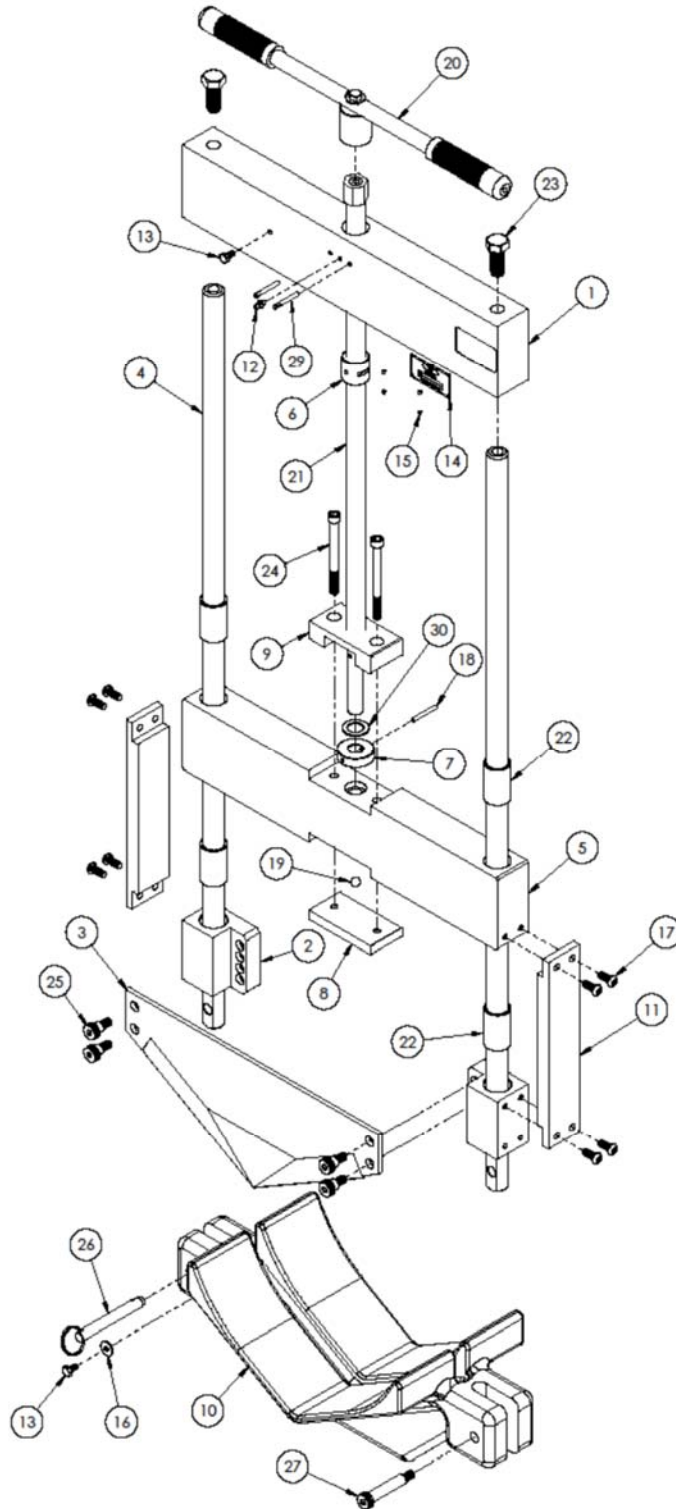

Model 1897

Guillotine Pipe Cutters

Item	Part No	Description	Qty
1	701283	HEAD BAR	1
2	701453	BLADE BLOCK	2
3	701454	POINTED BLADE	1
4	701285	GUIDE ROD	2
5	701284	BEARING BAR	1
6	701362	ACME THEADED BUSHING	1
7	701319	COLLAR	1
8	701281	PRESSURE PLATE	1
9	701433	LIFT BLOCK	1
10	701439	V-BASE (MACHINED)	1
11	701459	SIDE SUPPORT	2
12	277097	GREASE FITTING	1
13	276536	1/4"-20 x 1/2 SS HHCS	2
14	700595	NAME PLATE	1
15	276203	METAL TAK	4
16	276540	1/4" FLAT WASHER	1
17	276527	5/16-18 x 3/4" SS BHCS	8
18	275862	3/16" DIA x 1 1/2" ROLL PIN	1
19	277194	BALL BEARING	1
20	700674	HANDLE ASSEMBLY	1
21	701456	FEED SCREW ASSEMBLY	1
22	276637	SLEEVE BEARING	4
23	276644	5/8-11 X 1 1/2" HEX HEAD CAP SCREW	2
24	277234	3/8-16 X 4" L SHCS	2
25	277232	1/2" x 3/8" L SOCKET HEAD SHOULDER SCREW	4
26	277233	1/2" DIA x 3.1" L COTTERLESS PIN	1
27	277235	1/2" DIA X 2 1/4" L SHSS	1
28	276073	6" LANYARD ***NOT SHOWN***	1
29	277247	1/4 GROOVED DOWEL PIN	2
30	1716	THRUST WASHER	1

Model 1897

Guillotine Pipe Cutters

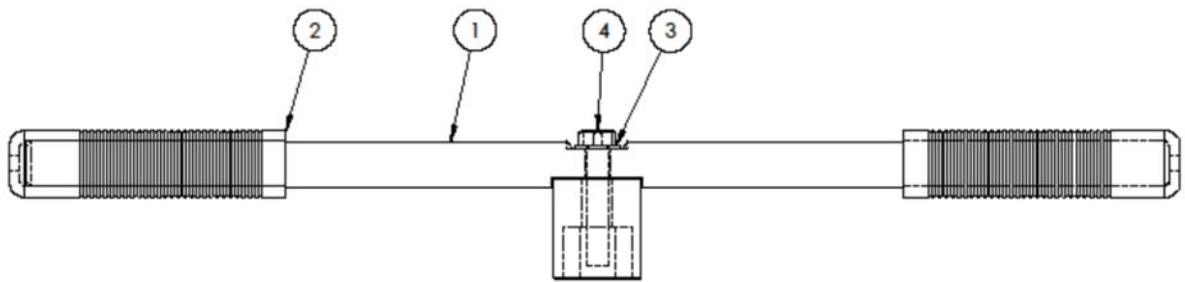

DESCRIPTION: HANDLE ASSEMBLY
PART NO. 700674

Guillotine Pipe Cutters

Item	Part No	Description	Qty
1	700675	HANDLE	1
2	154	GRIP	2
3	275685	5/16" FLAT WASHER	1
4	276326	3/8-16 x 2" HEX HEAD BOLT	1



Wheeler Rex ▪ 3744 Jefferson Road ▪ Ashtabula, OH 44004
Tel: 800-321-7950 or 440-998-2788 ▪ Fax: 440-992-2925
wheeler@wheelerrex.com ▪ www.wheelerrex.com
