

1661 Hole Cutter

Operation & Service Manual



Wheeler-Rex • Ashtabula, Ohio
Tel: 800-321-7950 • Fax: 440-992-2925
wheeler@wheelerrex.com • www.wheelerrex.com

Choosing the Shell Cutter

There are three different types of shell cutters.



For Clay and Concrete

Nominal Hole Size	Part No.
4"	3395
4 1/2"	3450
6"	3595
6 1/2"	3650



**For Reinforced Concrete,
Clay, Ductile Iron and Cast Iron**

Nominal Hole Size	Part No.
4"	6395
4 1/2"	6450
6"	6595
6 1/2"	6650
8"	6800



For Plastic

Nominal Hole Size	Part No.
4"	4395
4 1/2"	4450
6"	4595
6 1/2"	4650
8"	4800

Changing the Shell Cutter



Remove the two (2) screws from the arbor.



Loosen the set screw with the Allen key and insert pilot drill. Make sure pilot drill is aligned for the set screw to tighten on drill flat.



Attach the shell cutter with the two (2) screws.

**** Shell cutters & pilot drill are sold separately from the hole cutter unit.****

Hole Cutter Setup



Set the hole cutter on the pipe.

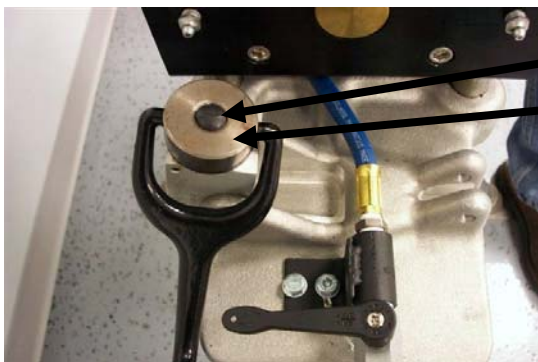

Screw

Nut

Unscrew hand clamp until screw is flush with nut.



Make sure the pipe is nested properly in the saddle of the base casting. Pull chain under pipe and back to casting base. Place one chain link between casting and push pin through base and chain link. Tighten chain with hand crank.

Preparing for the Cut

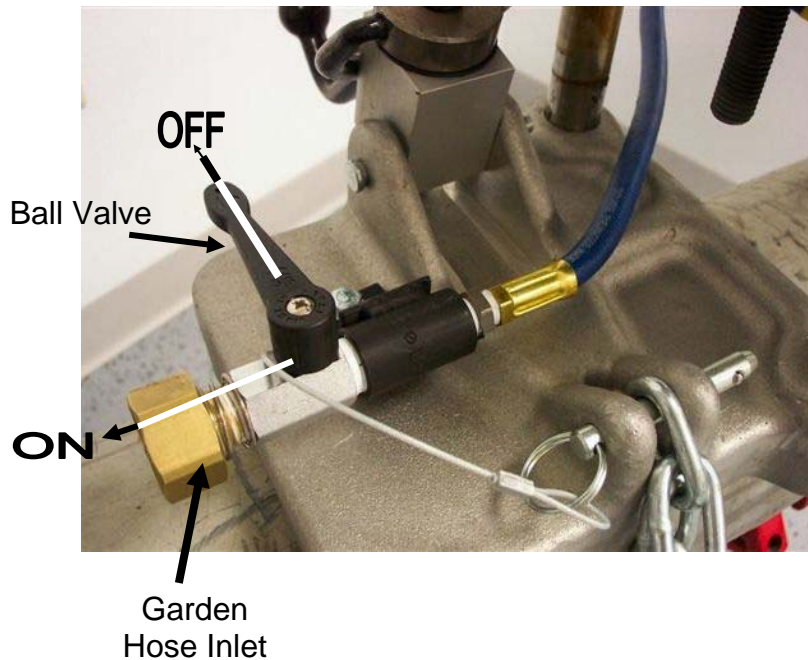

Attach garden hose to valve connection. Turn water on at source. Keep ball valve "OFF" until ready to make cut. This ball valve can also be used to control the water flow.



Adjust flexible hose for water stream to point on shell cutter. This is to help keep the cutter cool as well as flush away chips.

Air Regulator with Filter and Oiler

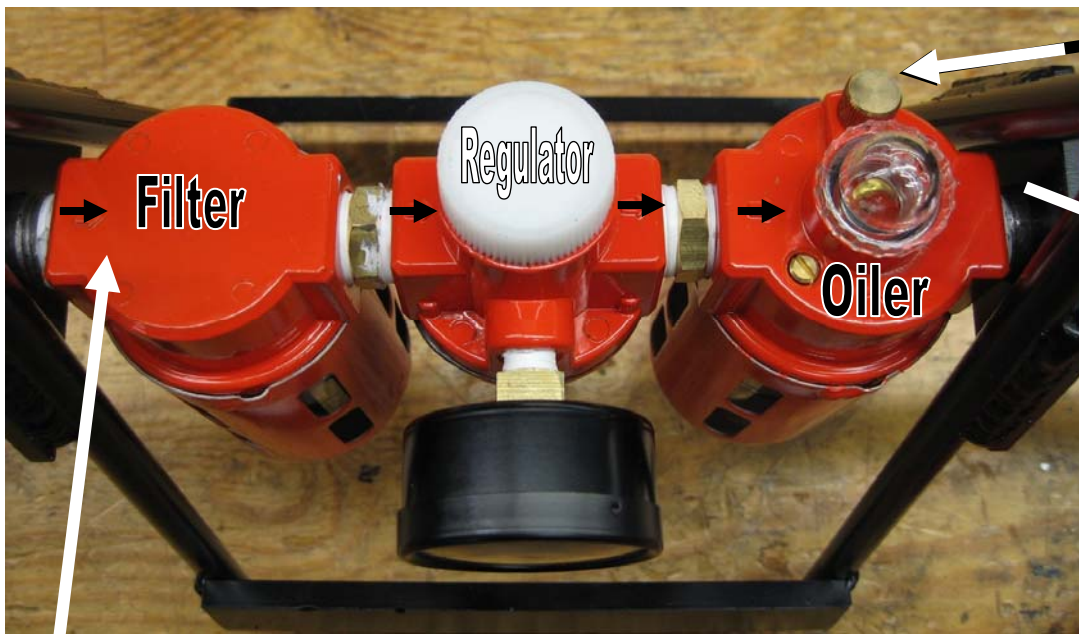

Oil Fill Cap

To Air Motor

**From
Compressor**

Fill reservoir with detergent or non-detergent SAE #10 engine oil to the noted fill line (see page 7)

Air Regulator / Oiler

Air Pressure Regulator



Oil Fill Line
**Air Pressure
Adjust Knob**

Connect Air Line to Regulator

**From Air Supply
or Compressor**

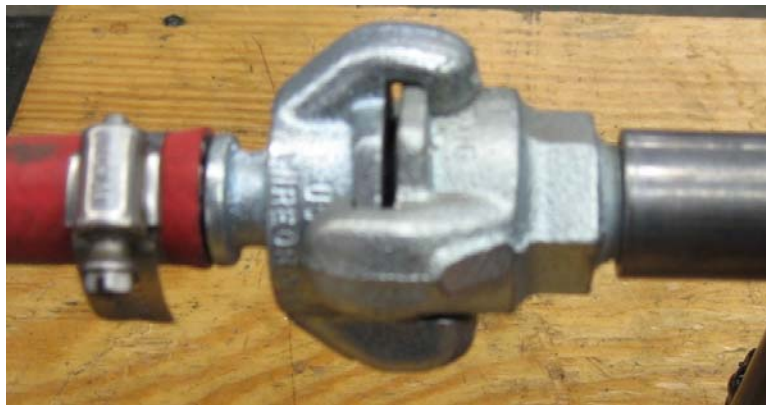

Safety Clip

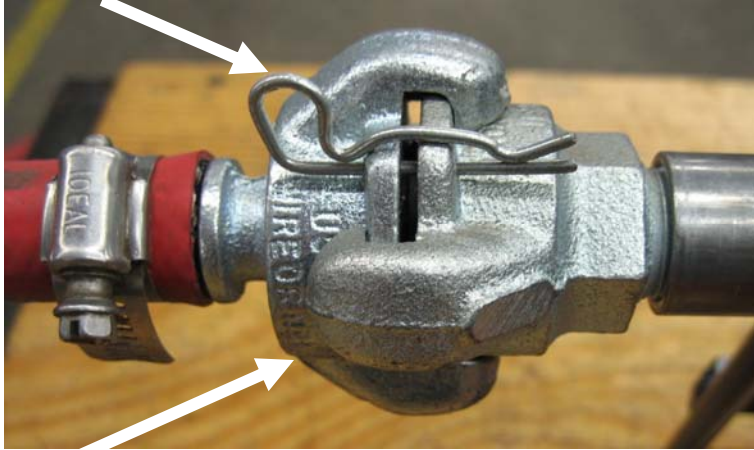

Make sure to use safety clips or wire tie air connections together. There are two pins required per connection.

Second safety clip is on the bottom

Make sure to use clips or wire on connection

Air Motor



Connect Air Line

From Air Regulator Assembly

Making the Cut

1. Fill oil reservoir
2. Connect air hose from compressor to air regulator using safety clips.
3. Connect air hose between air regulator and hole cutter using safety clips.
4. Turn on air compressor.
5. Turn air valve to ON position located on air motor.
6. Adjust air pressure as needed on air regulator.
7. Turn fluid valve to ON position.

8.



Slowly turn feed hand wheel in the clockwise position to lower the shell cutter. A heavy feed rate may damage shell cutter or pipe that is being cut. Allow shell cutter to cut material with a slow, steady turn of the feed wheel. If at anytime there are problems making the cut, stop cutting immediately.

Other Options

The hole cutter is a modular system where the base, feed mechanism and arbor assembly remain the same. The power supply is interchangeable with four different options: Electric, gas, pneumatic, & hydraulic.

Here is how to change power supplies:

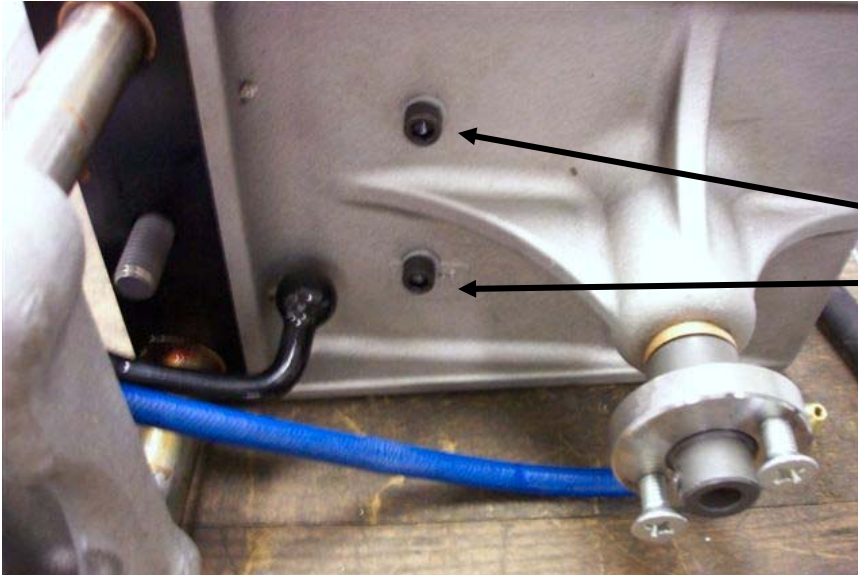

Remove the two (2) socket head cap screws from the platform.

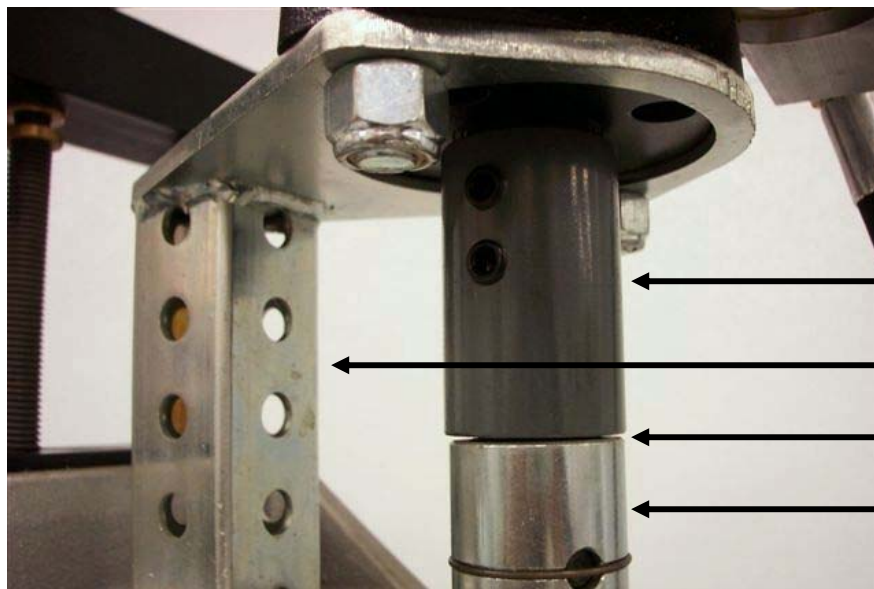

Arbor Coupling

Motor Bracket

Separation Point

Arbor Assembly

Separate the motor assembly from the arbor assembly. You can now replace the power assembly.

Maintenance

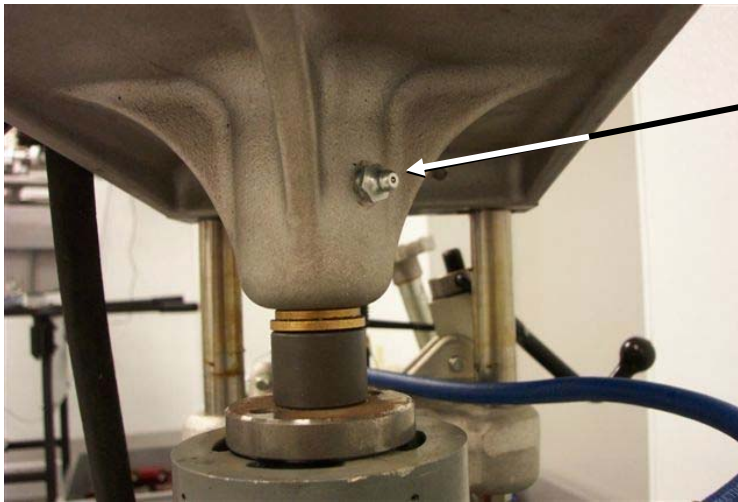

Grease Fitting

Grease arbor shaft prior to each use.

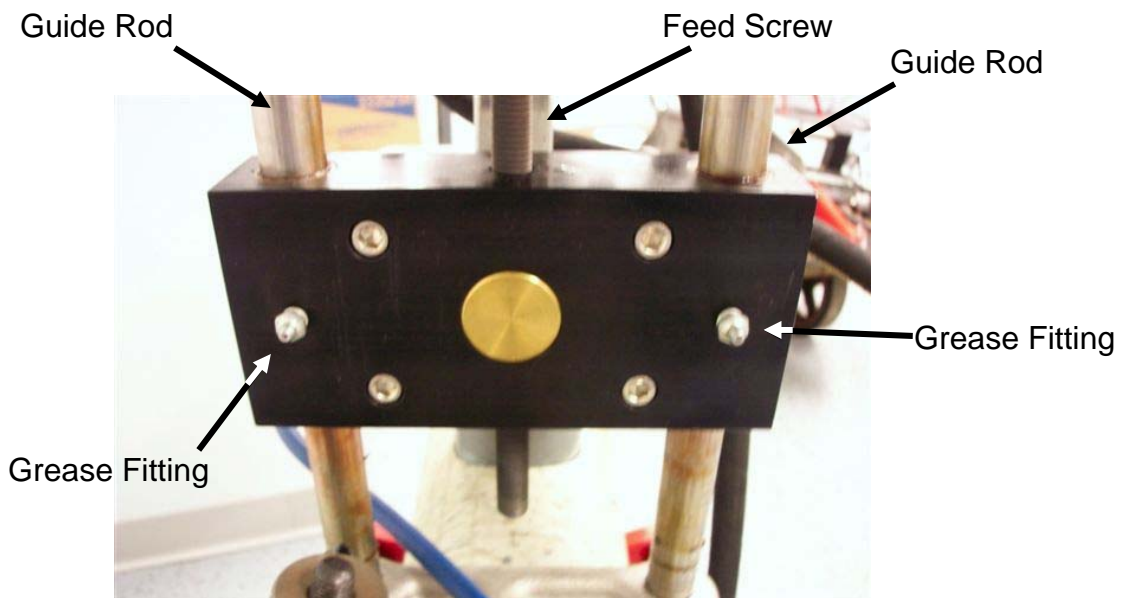

Guide Rod

Feed Screw

Guide Rod

Grease Fitting

Grease Fitting

Grease guide rod bushings prior to each use. Clean guide rods after each use. Clean feed screw before and after each use.

Hole Cutter System Information

- ⇒ For cutting 4"-8" holes into clay tile, ductile iron, cast iron, plastic and reinforced concrete pipes from 6" - 20" OD.
- ⇒ Complete with water valve assembly
- ⇒ Air Requirements
 - 70 - 80 psi (4.6-5.5 bar) minimum - 100psi maximum
 - 50 - 60 cfm (1400-1700lpm) minimum
- ⇒ Set up time approximately 5-10 minutes
- ⇒ Cutting time approximately 5-10 minutes

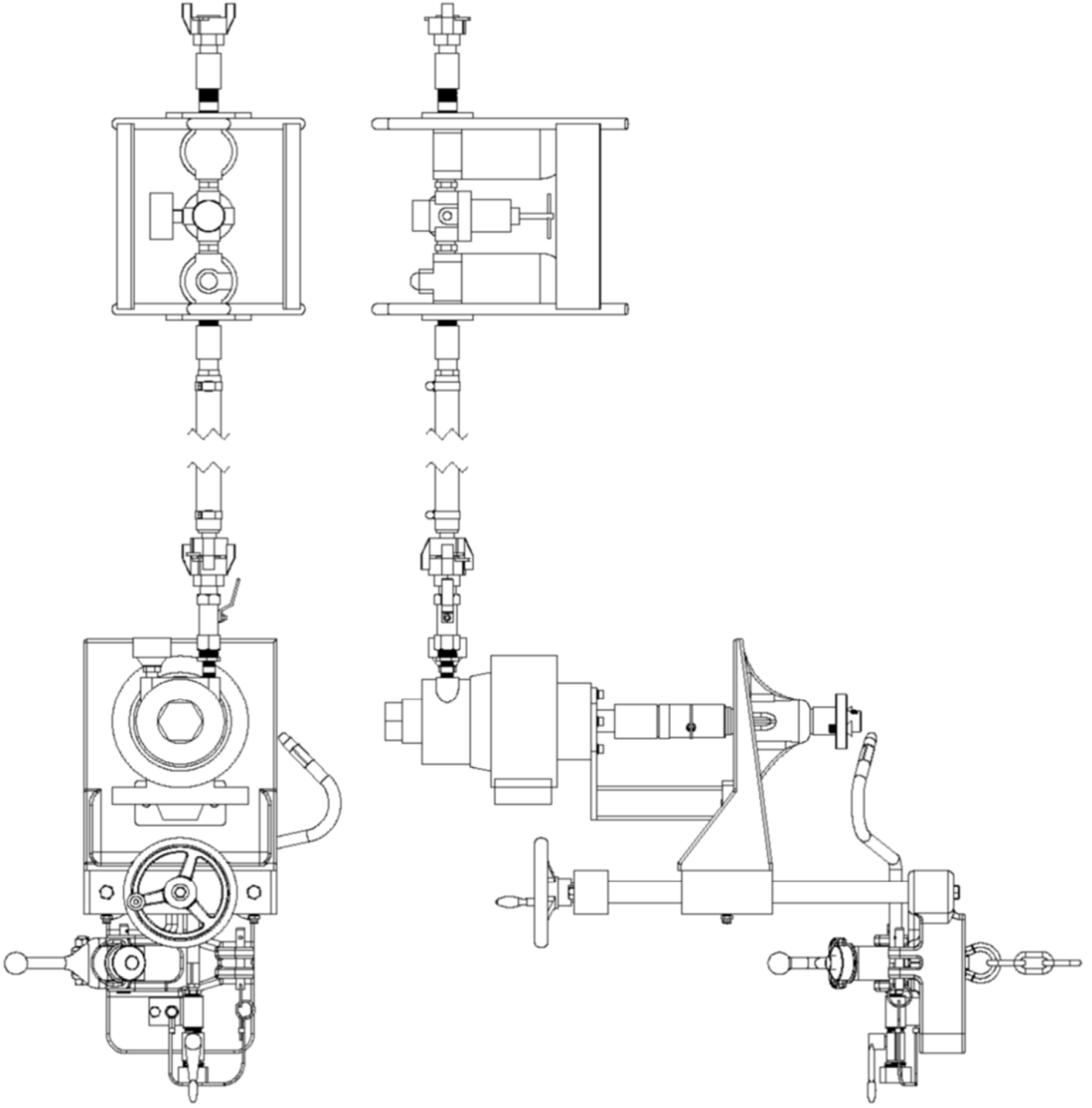

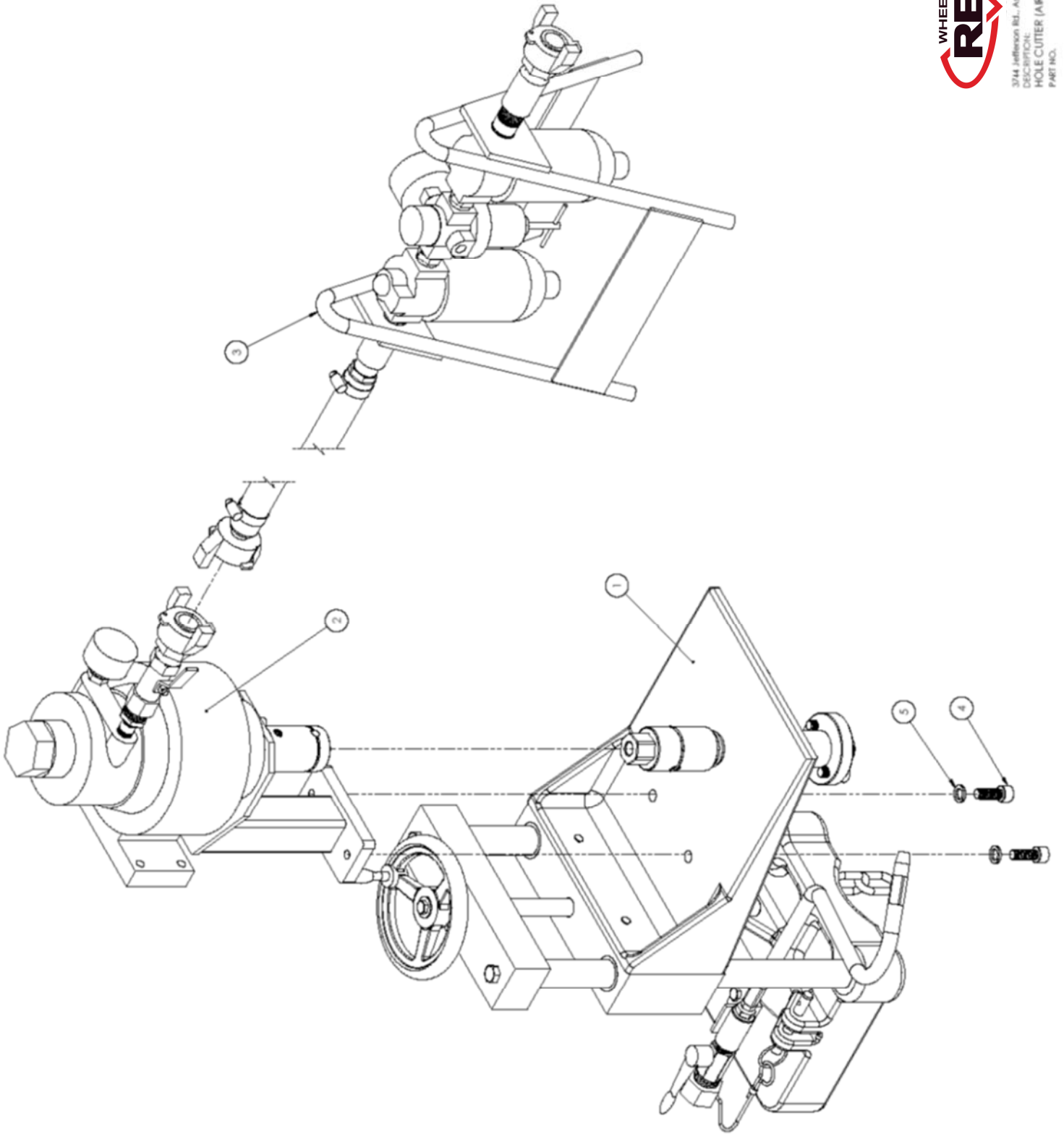

ITEM NO.	PART NUMBER	DESCRIPTION	QTY
1	700420	HOLE CUTTER ASSEMBLY	1
2	700453	AIR MOTOR & MOUNT ASSEMBLY	1
3	700489	AIR CONTROL ASSEMBLY	1
4	275118	3/8-16 x 1" SOCKET HEAD CAP SCREW	2
5	7179	3/8" SPLIT LOCK WASHER	2



3744 Jefferson Rd., Ashland, OH 44005
DESCRIPTION:
HOLE CUTTER ASSEMBLY
PART NO. 700420

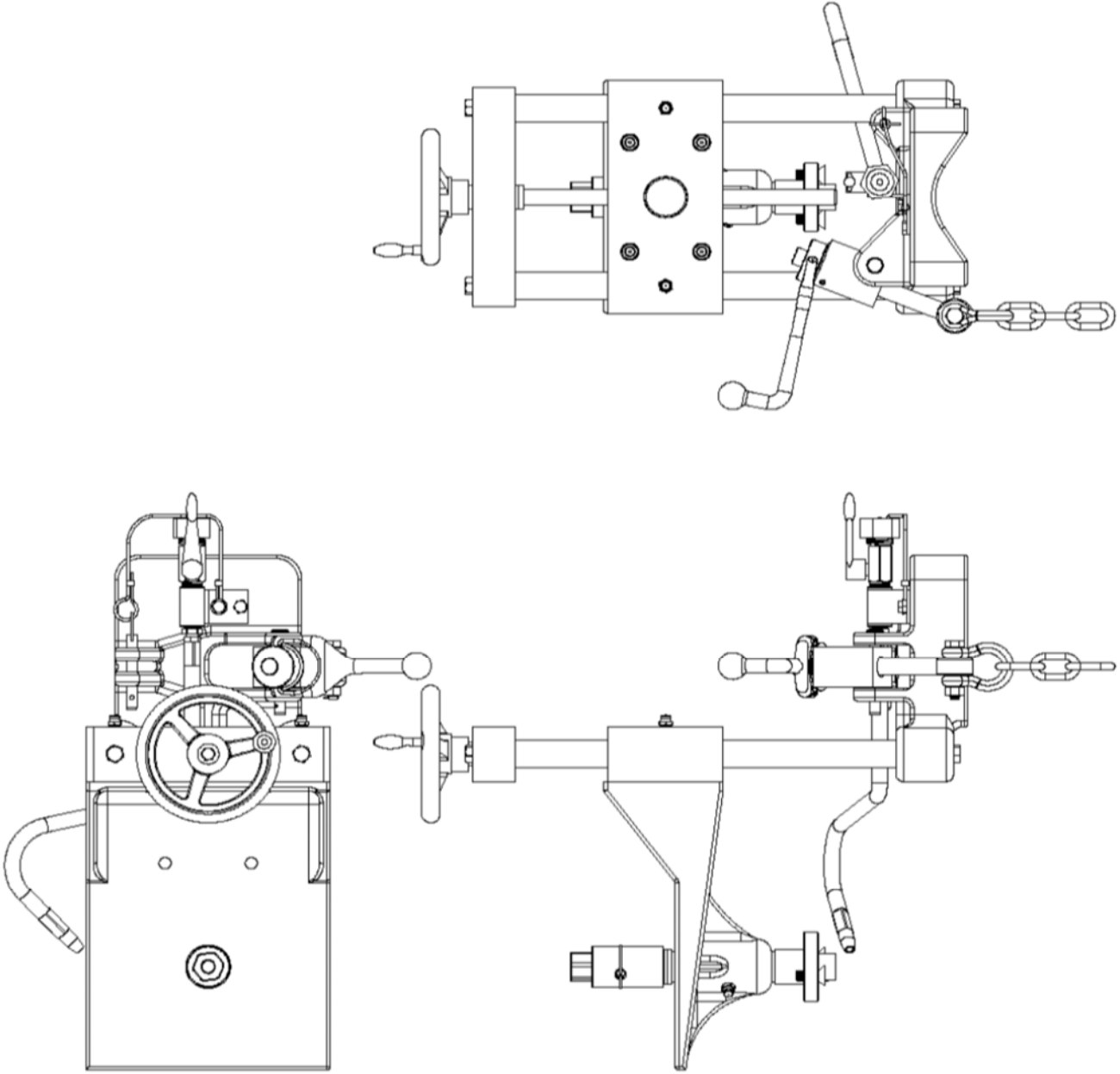

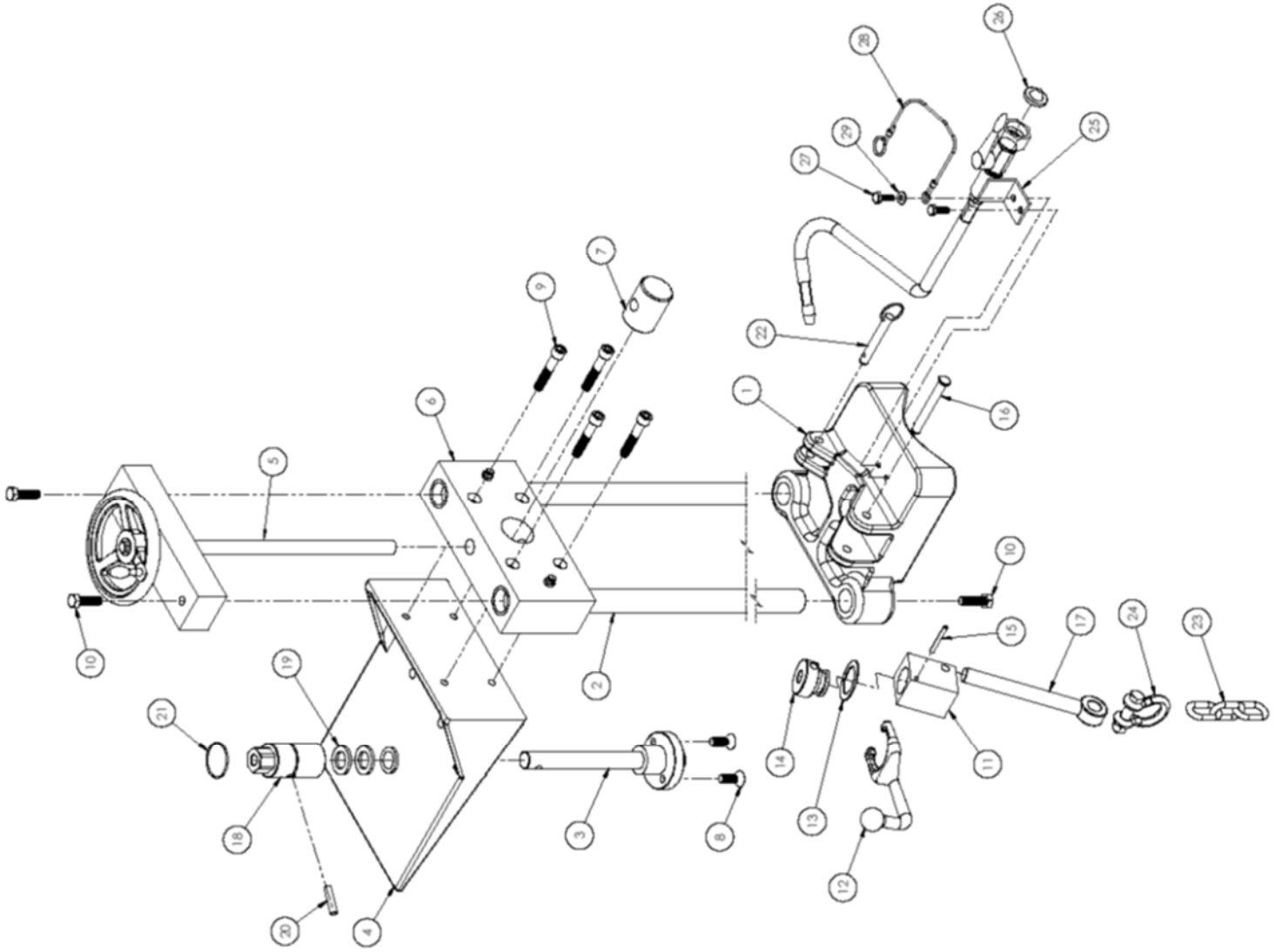

Item	PN	Description	Qty
1	700991	Base (MACHINED)	1
2	700431	ROD	2
3	700443	ARBOR ASSEMBLY	1
4	700441	ARBOR HOUSING ASSEMBLY	1
5	700438	HEAD ASSEMBLY	1
6	700433	ELEVATOR ASSEMBLY	1
7	700436	DRIVE BLOCK	1
8	12011	3/8-16 x 1" PHILLIPS FLAT HEAD MACHINE SCREW	2
9	276547	3/8-16 x 2" SHCS	4
10	276541	3/8-16 x 1 1/4" SS HEX HEAD CAP SCREW	4
11	700985	CHAIN TENSION BLOCK	1
12	606742	HANDLE	1
13	606751	BEARING	1
14	700989	CRANK NUT	1
15	275862	3/16" DIA x 1 1/2" ROLL PIN	1
16	276892	COTTERLESS CLEVIS PIN 3/8" x 3" LONG	1
17	276592	5/8-11 x 6" FULLY THREADED EYE BOLT	1
18	700445	BORING CAP	1
19	276481	THRUST BEARING (ST 2440-4)	2
20	276097	DOWEL PIN	1
21	260	CAP PIN RETAINER	1
22	276891	3/8" x 2" LONG DETENT PIN	1
23	700397	6' LONG CHAIN	1
24	276591	3/8" x 1" CHAIN SHACKLE	1
25	701079	FLUID ASSEMBLY	1
26	275917	STRAINER	1
27	560081	1/4-20 x 3/4" HHCS	2
28	276073	6" LANYARD	1
29	10713	3/16" FLAT WASHER	1

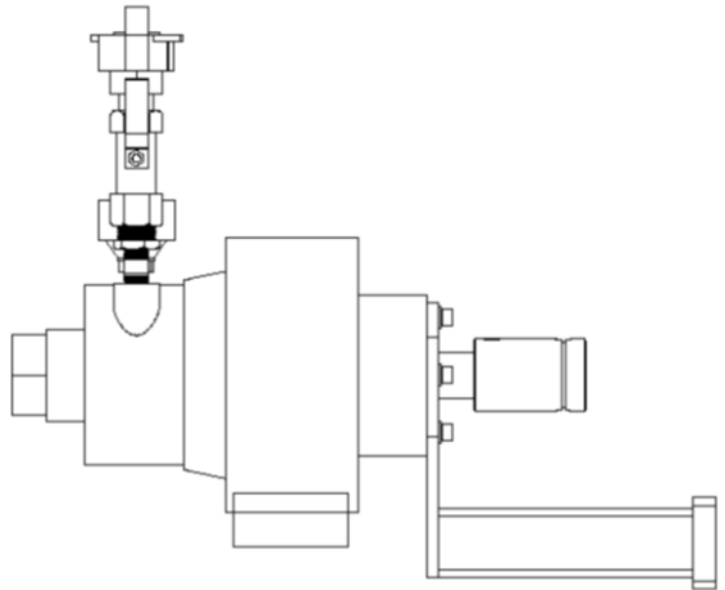
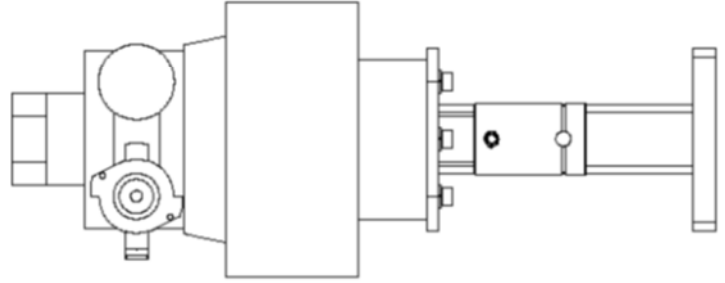
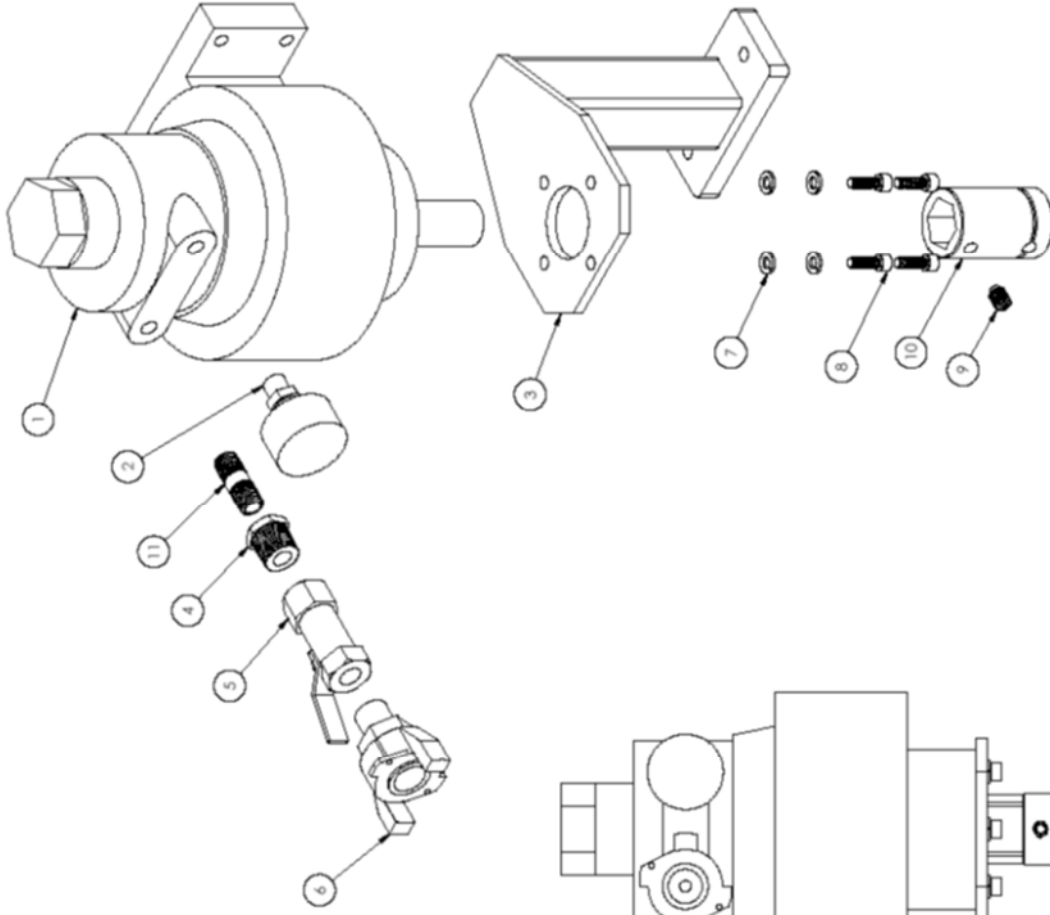

ITEM NO.	PART NUMBER	DESCRIPTION	QTY
1	276522	AIR MOTOR	1
2	276546	SILENCER	1
3	700454	AIR MOTOR MOUNT ASSEMBLY	1
4	275670	1/2 x 1/4 FS SCRD HX BUSH	1
5	275665	1/2" VALVE	1
6	276544	AIR COUPLING AM2	1
7	275105	1/4" SPLIT LOCK WASHER	4
8	4181	1/4-20 x 3/4" SHCS	4
9	276119	3/8-16 x 1/2" FULL DOG SET SCREW	1
10	220366	POWER ADAPTOR	1
11	276465	1/4" x 1 1/2" PIPE NIPPLE	1

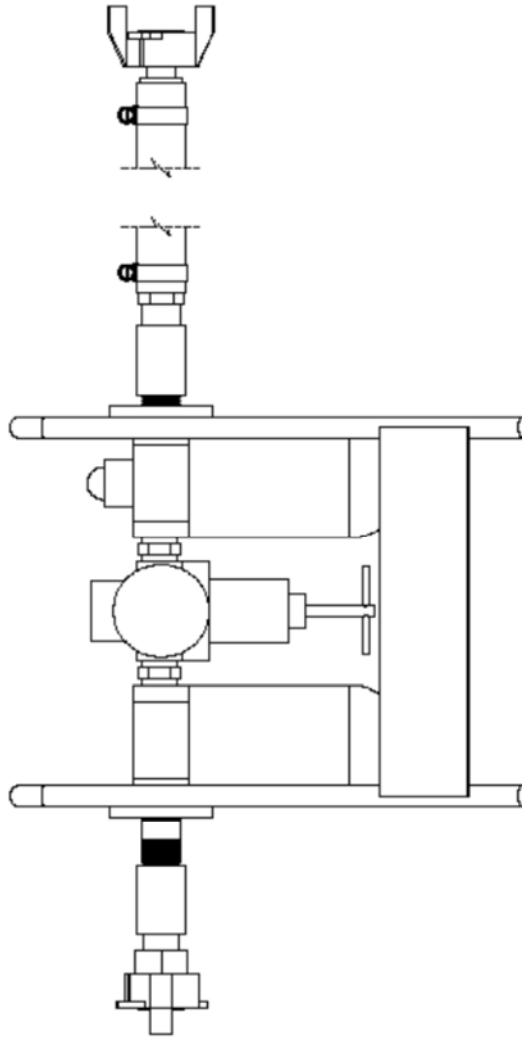
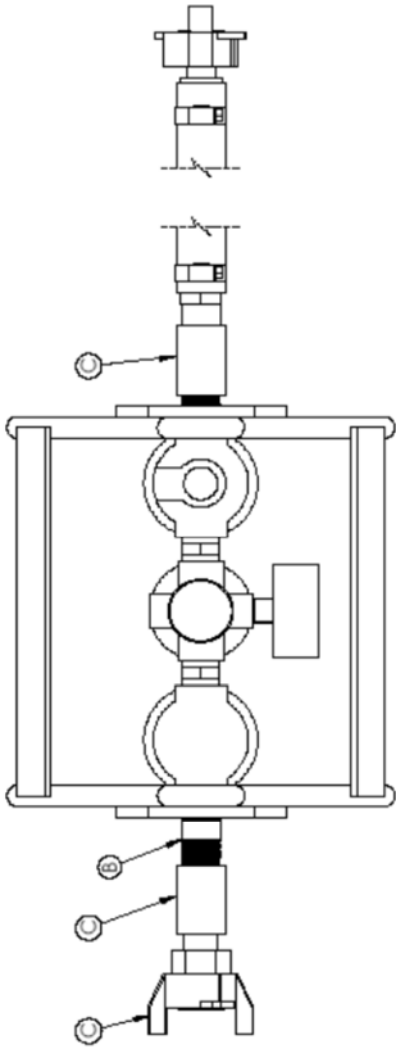

3744 Jefferson Rd., Ashland, OH 44005

DESCRIPTION:

AIR CONTROL ASSEMBLY

PART NO

700489

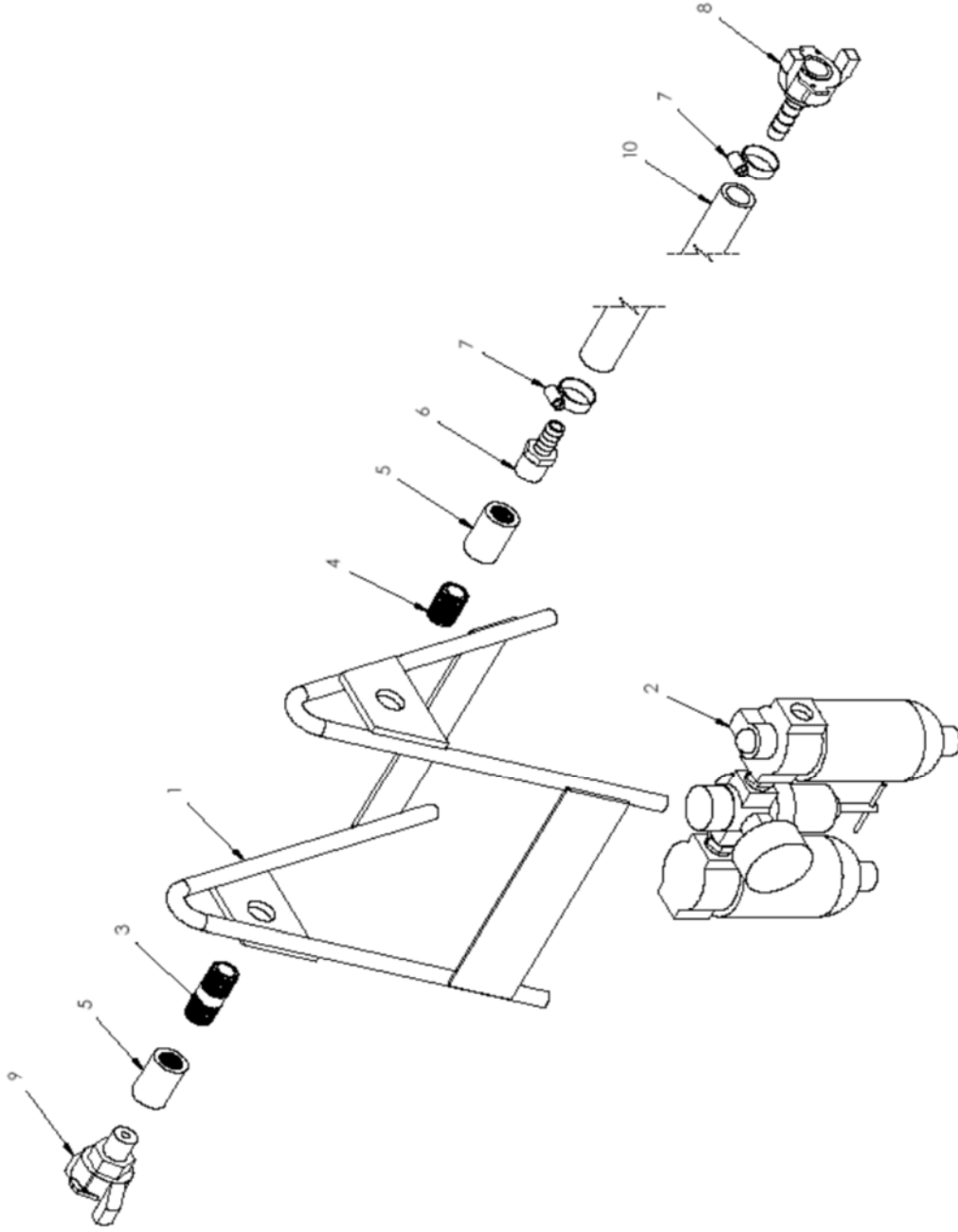

3744 Jefferson Rd., Ashbabula, OH 44005
DESCRIPTION:
AIR CONTROL ASSEMBLY
PART NO. 700489

ITEM NO.	PART NUMBER	DESCRIPTION	QTY
1	700488	STAND ASSEMBLY	1
2	276559	FILTER, REGULATOR, & LUBRICATOR ASSEMBLY	1
3	275633	1/2 X 2" XH PIPE NIPPLE	1
4	275669	1/2 x CLOSE PIPE NIPPLE	1
5	275475	1/2" COUPLING	2
6	275496	1/2" HOSE BARB	1
7	276550	HOSE CLAMP	2
8	276545	AIR COUPLING AM1	1
9	276544	AIR COUPLING AM2	1
10	700490	HOSE	1