

SUBMITTAL INFORMATION

Mechanical Joint Retainer (UFR1500-x-I style)

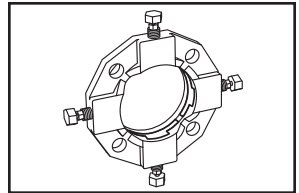

3" - 12" SERIES UFR1500 CIRCLE-LOCK MECHANICAL JOINT RESTRAINT FOR C900, C909 AND IPS PVC

Ductile iron actuating screw, with the Auto-Tork break-away head design, ensures proper torque during installation.

Safety stop ensures ring segments can never be over-tightened.

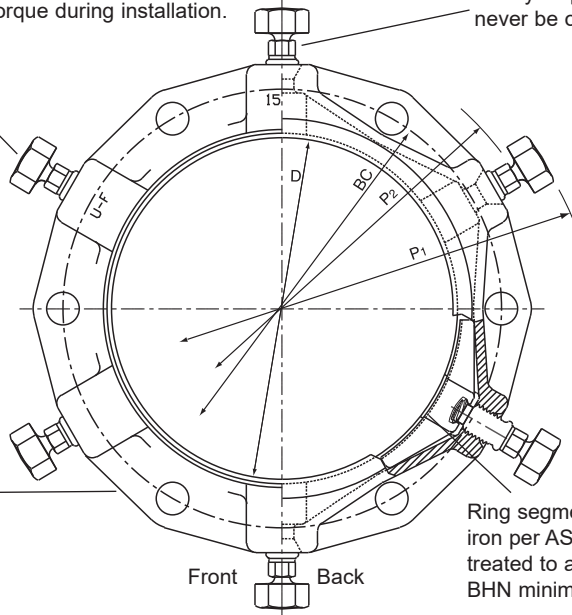

Gland body is of high strength ductile iron per ASTM A536, grade 65-45-12. Compatible with all mechanical joints conforming to ANSI / AWWA C111 / A21.11.

Ring segments are ductile iron per ASTM A536 and heat treated to a hardness of 370 BHN minimum.

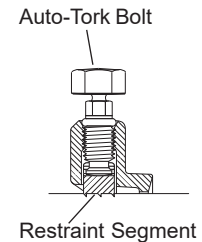

NOM. PIPE SIZE	O.D.	CATALOG NUMBER	NO. OF RESTRAINT SEGMENTS	APPROX. WEIGHT (LBS.)	P1*	P2**		BC	D	PRESSURE RATING					✓ SUBMITTED ITEM(S)
						C900	C909			C900		C909	ASTM D2241		
										DR-18	DR-14		PC-235	SDR-26	
3"	3.50"	UFR1500-3-I	4	9	11.50"	-	9.00"	6.19"	4.06"	-	-	-	160 PSI	200 PSI	
4"	4.50"-4.80"	UFR1500-4-I	4	10	13.00"	9.40"	9.25"	7.50"	4.90"	235 PSI	305 PSI	-	160 PSI	200 PSI	
6"	6.63"-6.90"	UFR1500-6-I	6	14	15.13"	11.60"	11.65"	9.50"	7.00"	235 PSI	305 PSI	235 PSI	160 PSI	200 PSI	
8"	8.63"-9.05"	UFR1500-8-I	6	18	17.25"	13.75"	13.60"	11.75"	9.15"	235 PSI	305 PSI	235 PSI	160 PSI	200 PSI	
10"	10.75"-11.10"	UFR1500-10-I	8	25	19.38"	16.00"	15.85"	14.00"	11.20"	235 PSI	305 PSI	235 PSI	160 PSI	200 PSI	
12"	12.75"-13.20"	UFR1500-12-I	8	29	21.50"	18.05"	17.85"	16.25"	13.30"	235 PSI	305 PSI	235 PSI	160 PSI	200 PSI	

*Maximum O.D. of gland on pipe before Auto-Tork heads are removed (as shipped).

**Maximum O.D. of gland on pipe after Auto-Tork heads are removed.

FEATURES

- Fits C900, C909 and ASTM D2241 IPS PVC
- Full circle contact and support of the pipe wall
- "Auto-Tork" actuating screws with heads specially designed to twist off at the correct installation torque, leaving a hex head in case future system maintenance or removal is required
- Restraining segments are mechanically retained in pockets
- Series 1500 eliminates the need to pour expensive and time consuming concrete thrust blocks
- Series 1500 UL/FM approved, 4"-12" nominal size C900 PVC, for use on listed and approved PVC pipe
- Imported ductile iron castings
- Gland, screws and segments are protected with black Armorguard e-coat
- Gland colored red for identification purposes
- Assembled, inspected and packaged in the U.S.A.

The Ford Meter Box Company considers the information in this submittal form to be correct at the time of publication. Item and option availability, including specifications, are subject to change without notice. Please verify that your product information is current.



The Ford Meter Box Company, Inc.

P.O. Box 443, Wabash, Indiana U.S.A. 46992-0443

Phone: 260-563-3171 / Fax: 800-826-3487

Overseas Fax: 260-563-0167

www.fordmeterbox.com



08/03/16

Submitted By: